

# **A Pilot Study of a New Sampling Design for the Access Point Angler Intercept Survey**

**Submitted by the  
MRIP Design and Analysis Workgroup:**

F. Jay Breidt, Colorado State University

James R. Chromy, RTI International

Kelly E. Fitzpatrick, NOAA Fisheries Southeast Fisheries Science Center

Han-Lin Lai, NOAA Fisheries Office of Science and Technology

Terri Menzel, Florida Fish and Wildlife Conservation Commission

Douglas G. Mumford, North Carolina Division of Marine Fisheries

Breda Muñoz, RTI International

Jean D. Opsomer, Colorado State University

Ronald J. Salz, NOAA Fisheries Office of Science and Technology

Kevin M. Sullivan, New Hampshire Department of Fish and Game

David A. Van Voorhees, NOAA Fisheries Office of Science and Technology

Chris Wilson, North Carolina Division of Marine Fisheries

Patricia A. Zielinski NOAA Fisheries Office of Science and Technology

## Contents

1. Executive Summary .....	4
2. Introduction and Background.....	15
3. Methodology .....	18
3.1 Pilot Survey Data Collection Methods.....	18
3.1.1 Sampling Methods.....	20
3.1.1.1 Expanded Coverage and Fixed Time Intervals.....	20
3.1.1.2. Clustering of Sites .....	22
3.1.1.3 Clustering Method.....	23
3.1.1.4 Formalized Probability Sampling of Sites .....	24
3.1.1.5 Regional Stratification .....	24
3.1.1.6 Sample Size and Allocation.....	25
3.1.1.7 Sample Frame and Assignment Draw .....	26
3.1.2 Issuing and Completing Assignments .....	27
3.1.3 On-Site Interviewing Procedures.....	28
3.1.3.1 Definition of an Eligible Angler Trip.....	28
3.1.3.2 Angler Trip Counts (SSU Cluster Sizes) .....	29
3.1.3.3 Intercept Limit per Assignment.....	31
3.1.3.4 Form Changes for Pilot .....	31
3.2 Methods used for Data Analysis and Examination of Differences in Sampling Yield, Estimators, and Statistical Precision.....	33
3.2.1 Sampling Yield .....	33
3.2.2 Comparisons of Survey Estimates .....	33
3.2.3 Comparison of the Statistical Precision of Estimators .....	34
4. Results and Analyses .....	35
4.1 Sampling Yield .....	35

4.2 Comparison of Pilot and (weighted) MRFSS Effort and Catch Estimates .....	41
4.3 Statistical Precision of Estimators .....	53
5. Discussion and Recommendations .....	56
5.1 Discussion of Differences .....	56
5.2 Recommendations for Immediate Action .....	65
5.3 Recommendations for Future Consideration .....	69
6. Literature Cited .....	76
7. Acknowledgements .....	77

## 1. Executive Summary

An expert review conducted by the National Research Council (2006) identified problems in the Access Point Angler Intercept Survey (APAIS, or “intercept survey”) that the NOAA Fisheries Service has conducted for many years as a component of the Marine Recreational Fisheries Statistics Survey (MRFSS). The survey estimators and measures of precision were not accounting for the complex sampling design, the data collection protocols were combining formal randomization with subjective decision-making in ways that make it difficult to develop statistically valid estimators, and the spatiotemporal sampling frame was not providing coverage of fishing trips ending on private property or at night.

The Marine Recreational Information Program’s Design and Analysis Work Group (DAWG) initiated work in 2008 to address these concerns with the help of expert consultants. A first project completed in 2011 produced a new weighted estimation method that appropriately accounts for the MRFSS sampling design (Breidt et al., 2011). The NOAA Fisheries Service subsequently applied this method to produce design-unbiased annual estimates of 2004-2011 total finfish catches for the Atlantic and Gulf of Mexico. A second project initiated in 2009 focused on developing a new sampling design for the intercept survey that would address additional NRC concerns about the data collection protocols and temporal coverage of sampling, as well as specific recommendations provided by Breidt et al. (2011) to further improve its statistical validity and accuracy. This report describes the results of a 2010 pilot study conducted in North Carolina that tested the feasibility of implementing this new sampling design and assessed its effects on various measures of survey performance through side-by-side comparisons with the ongoing MRFSS APAIS sampling. This study did not aim to evaluate the relative merits of the two designs for the purpose of determining which one is better to use in future years, but rather it focused on developing a better understanding of how the changes to the new design would potentially affect sampling efficiency, statistical accuracy, and statistical precision going forward. This information is needed for assessing any possible needs for further modification that would ensure efficient and effective coastwide implementation of the new sampling design.

### **SAMPLING METHOD CHANGES:**

The new sampling design tested in the pilot study incorporated a number of methodological changes needed to significantly improve the survey's statistical validity and accuracy.

***Time of Day Stratification:*** In the new design, sampling is stratified among four six-hour time intervals to ensure some coverage of fishing trips ending at all different times of day. In the original MRFSS sampling design, samplers were instructed to visit each assigned site during the “peak” hours when most fishing trips would be ending. In the new sampling design, samplers are assigned to a specified time interval, and the start and stop times for interviewing at each assigned site are fixed. Variability among samplers in the time intervals chosen for data collection is now eliminated. This change eliminates a potential bias when mean catch rates or proportions of coastal resident trips differ between peak and off-peak periods of fishing activity.

***Geographic Stratification:*** Sampling was stratified geographically in the pilot. Samplers were hired for one of three state subregions within North Carolina and only completed assignments within that particular geographic stratum. North Carolina sampling under the MRFSS design had never been stratified in this manner. This change allowed for more representative coverage of different management areas and also made it easier to manage staffing of the interviewing assignments.

***Clustering of Sites for Sampling:*** Low activity sites are clustered to form two- or three-site clusters in the new frame used for sampling. Sites expected to have a high level of activity are not clustered with other sites. The clustering of lower pressure sites into multi-site units increases their inclusion probabilities relative to the higher-pressure sites. Higher-activity sites still have higher inclusion probabilities than lower activity sites in the new sampling design, but there is generally less variability among sites in their probabilities and a greater chance that the sample is spread more evenly among sites that have similar fishing pressure. Samplers are required to visit all sites within the assigned cluster following a predetermined visitation order and times. Samplers are instructed to spend two hours at each site within the cluster before moving to the next site. By contrast, the MRFSS sampling frame consisted of individual sites only. Samplers were given discretion to visit “alternate” sites and to determine how long to spend at each site visited.

***Sampling Frame and Probability Sampling:*** The selection of all specific locations in space and time for interviewing assignments (i.e., the primary sampling units, or PSUs) is formalized based on a probability-proportional-to-size (PPS) approach. Thus, the new design uses a purely design-based approach to determining all site selection probabilities. Sampling under the MRFSS design also used a formal PPS approach to select primary sites (based on expected fishing pressure), but did not use a formal probability-based approach to select alternate sites. The formalization of a probability sampling approach for the selection of all interviewing locations allows more accurate determination of the correct sampling weights to be used in the estimation process.

***Issuing and Completing Assignments:*** Under the new design, emphasis is placed on completing all interviewing assignments selected by probabilistic sampling. All assignments drawn have to be either completed as assigned or canceled, because rescheduling is not allowed. By contrast, with the MRFSS design the emphasis was on attaining specified interview quotas rather than completing all drawn assignments. Eliminating assignment rescheduling greatly reduces the possibility of a nonresponse bias that could result from a failure to obtain observations from some of the selected assignments. It also eliminates possible temporal undercoverage biases that could result from the rescheduling of assignments.

***Interviewing limits:*** The new design removes all limits on the number of interviews obtained by samplers during an assignment. Samplers are directed to continue interviewing for the full specified duration of each site assignment. The MRFSS design instructed samplers to end an assignment when they reached an established cap on the number of interviews.

***Elimination of Opportunistic Sampling:*** Sampling of fishing trips in fishing mode strata other than the one for which an assignment was selected is no longer allowed under the new design. The MRFSS design traditionally allowed samplers to obtain interviews in “alternate” modes as a means of increasing the overall numbers of interviews, although alternate mode interviews were not allowed under the MRFSS design either in 2010 when this pilot study was conducted.

***Eligibility for Interviews:*** Under the new design, all intercepted anglers who have completed fishing for the day in the assigned fishing mode are considered eligible for an interview or “proxy” interview in the case of very young anglers. The MRFSS sampling design excluded anglers less than five years old, as well as any anglers returning to a site where a fishing tournament is in progress.

***Complete vs. Incomplete Beach/Bank Interviews:*** For sampling in the beach/bank fishing mode, the new design specifies that only completed angler fishing trips are eligible for an interview. Under the MRFSS design, samplers were allowed to obtain “incomplete trip” interviews in beach/bank mode. This change removes a potential source of bias because anglers who fish for longer durations would have a higher probability of being intercepted for an “incomplete trip” interview and would likely have higher mean numbers of fish caught per trip.

***Angler Trip Counts:*** The new design strongly emphasizes the need for obtaining accurate counts of all eligible angler fishing trips ending at an assigned site during the assigned time interval. Although the MRFSS design required counts of completed trips not intercepted for interview since 1990, these counts were not used in the estimation process to determine appropriate sample weights until the recent implementation of the new MRIP weighted estimation method. The greater emphasis in the new design to obtain accurate counts of all completed angler fishing trips while on site is very important to assure greater accuracy in the calculation of the secondary stage sampling fractions needed for proper weighting of the data.

The new sampling design effectively spreads the sampling of angler trips during any assignment to represent a larger temporal slice of fishing. Intercepted trips represent a much larger proportion of the total count of completed angler trips in the sampled time intervals. This results in smaller expansion factors for estimating total count for any sampled time period from the observed counts.

***Questionnaires and Data Forms:*** With the exception of one question added to identify angler trips intercepted at tournament sites, the intercept survey questionnaire used for the new sampling design matched that used under the MRFSS design. A number of changes were made to the Assignment Summary Form (ASF) and Site Description Form (SDF) to accommodate the new design’s emphasis on obtaining more accurate counts and estimates of expected fishing pressures.

***ESTIMATION METHOD CHANGES:***

The access point intercept survey collects data needed to estimate the mean number of fish caught on marine recreational fishing trips. In addition, intercept survey data are used to estimate the proportion of fishing trips made by coastal county residents with a landline phone who could be contacted by the Coastal Household Telephone Survey of fishing effort. The inverse of this proportion comprises the “fishing effort adjustment

ratio” that is used as a multiplier to account for fishing trips by non-coastal and out-of-state residents or anglers without landline phones. The total adjusted effort estimate is then used to expand mean catch estimates into total catch estimates. Therefore, total catch is estimated as (total trips by coast county residents) \*(mean catch per angler fishing trip) \*(1/proportion of trips by coastal county residents).

The weighted estimation method developed by Breidt et al. (2011) was used to estimate catch rate and effort adjustment ratio statistics from data collected under the MRFSS sampling design. This method utilizes a mix of design-based and model-based approaches to determine the appropriate sampling weights used in estimation. A new weighted estimation method that is strictly design-based was developed to estimate the catch rate and effort adjustment ratio statistics from data collected under the new sampling design.

### ***COMPARISONS BETWEEN MRFSS and PILOT DESIGNS:***

The MRFSS design was run side-by-side with the new pilot design in North Carolina for a full year to facilitate direct comparisons between the two.

***Sampling Yield Comparison:*** Several measures of sampling yield were selected to compare the relative sampling efficiency and effectiveness of the new design with that of the MRFSS design. Overall, the MRFSS sampling obtained a greater mean number of interviews per assignment (7.56) than the sampling under the new design (3.44), as well as a much higher mean number of interviews per hour (1.97 vs. 0.57). The greatest differences in the number of intercepts obtained per assignment, per site, and per hour occurred in the beach/bank and charter boat fishing modes. The MRFSS also obtained higher mean counts of completed trips per assignment (9.71) than the new design(3.45). However, the MRFSS sampling observed fewer sites per assignment (2.09) than the new sampling design (2.46).

In terms of sampling efficiency, the MRFSS design yielded a much lower percentage of assignments resulting in no interviews (32%), as more than one-half (51%) of assignments completed under the new design obtained no interviews. Comparisons of the temporal distributions of interviews predictably showed that sampling under the new design obtained proportionately more interviews in the nighttime and morning hours than the MRFSS sampling design obtained. There was no clear trend found in comparing the average numbers of reported fish per assignment between the new design and the MRFSS.



**Comparison of Estimators:** In general, the two estimators of the proportion of fishing trips made by coastal county residents who could be contacted by the Coastal Household Telephone Survey produced very similar results. The only exception was in the beach/bank mode, where effort ratio estimators for MRFSS were higher than those for the new design. Although there is some suggestion that this difference could be attributable to the elimination of incomplete trip interviews or the inclusion of nighttime sampling under the new design, it was not possible to show a statistically significant difference in this proportion between complete and incomplete trip beach/bank interviews or between nighttime and daytime beach/bank trip interviews in this study. The possibility of a length of stay bias under the MRFSS design warrants further study.

Overall, no clear trends or systematic differences were found when comparing mean catch rate estimators. This was true for estimators of mean catch per trip for both removals (fish kept or released dead) and catch released alive. Removal estimates for seven of the 15 most commonly caught species were higher under the new design than under the MRFSS design. For the other eight species, the estimates based on the MRFSS design were higher. Confidence intervals overlapped for 13 out of the 15 landings estimates comparisons, suggesting that, for the large majority of cases, weighted annual catch estimates were not statistically different between the two sampling designs. In general, we expect that weighted catch estimates based on the new sampling design will be pretty similar to those based on the MRFSS sampling design for most species. However, there is some indication in this study that catch rate estimates for common night fishing targets will be higher under the new design due to the addition of formalized nighttime sampling assignments

The estimates generated from the MRFSS sampling design were more precise than the estimates generated from the Pilot design mainly due to the smaller sample sizes used for the Pilot design and differences in sample distribution across modes and state subregions. However, if the sample size and allocation of sampling among fishing modes and geographic strata for the pilot design had matched what was done under the MRFSS design, analyses suggest that the statistical precision of catch rate estimates under the Pilot design would have been at least as good, and possibly much greater, than what was obtained using the MRFSS sampling design. While these results are encouraging, they are based on small sample sizes and should, therefore, be interpreted cautiously. In addition, these analyses compared hypothetical Pilot variances with

MRFSS variances for total catch with all species combined, which may not necessarily reflect differences in variances one would expect to find for any particular species of interest.

It should also be noted that the potential for non-sampling errors is much greater under the MRFSS sampling design than under the new design. Under the MRFSS design, there is a greater chance that errors can occur due to undercoverage (almost no coverage of nighttime and off-peak daytime fishing trips) and nonresponse (failure to complete many assignments as drawn for sampling). Although sampling under the new design in this study yielded a much smaller percentage of completed assignments with at least one angler trip interview and a much smaller mean number of interviews on such assignments, changes in the allocation of sampling across sampling strata could greatly reduce these differences.

## ***RECOMMENDATIONS***

The Project Team identified specific recommendations based on results of this pilot study. In addition, we provide a number of recommendations for additional changes not implemented in this pilot study but that should be addressed prior to implementation of the new sampling design. Most of these recommendations focus on further improving the new sampling design to increase statistical precision without increasing costs. Finally, we identified several recommendations that require additional information and should be considered or evaluated in further studies.

### ***Recommendations for Immediate Action:***

- 1. In general, the Project Team recommends use of the new access point survey sampling design tested in this pilot study for conducting future access point surveys on the Atlantic coast and in the Gulf of Mexico.** The pilot study demonstrated that the new design is feasible to implement and has many advantages over the MRFSS design as described in this report.
- 2. The allocation of sampling among sampling strata should be changed as needed to maximize sampling efficiency and statistical precision.** Sampling could be allocated very differently among geographic strata, fishing mode strata, and time block strata than how it was allocated in this pilot study. Without introducing any bias, other sampling allocations will likely provide higher proportions of sampling assignments

that obtain at least one interview and may also provide higher average numbers of interviews per positive assignment than were observed in the pilot study. The goal should be to find the “optimal” allocation that will provide the highest level of statistical precision for the dollar spent.

3. **The formal PPS sampling of sites and site clusters should be controlled to ensure all drawn assignments can be completed by existing staff.** Staffing levels for the access point surveys should always be set to match the sampling levels required to deliver desired levels of statistical precision on resulting estimates of mean catch per trip. Once those staffing levels are established, a controlled selection program that incorporates staffing constraints can be used to ensure the draw of a probability sample of assignments that can be covered by the available staff.
4. **Provide clearer instructions to samplers about how to handle the catch of charter boat captains and crew.** Samplers should include any catch by the captain and crew that were mixed in with the observed catch recorded for a group of charter boat anglers, but they should not count the captain and crew as contributors to the mixed group catch.
5. **Collect total catch data for any intercepted angler who just completed a multi-day fishing trip.** In addition, ask for the number of waking days that the angler fished during the trip. This will allow accurate calculation of the angler’s mean catch per day for use in the mean catch estimates for the total population of angler trips.
6. **To increase on-site productivity and reduce driving time, instruct samplers to stay up to 3 hours (rather than only two hours) at the first site when a two-site cluster is assigned.**

***Recommendations for Future Consideration:***

1. **Consider using the average pressure of a site cluster rather than the total pressure to determine its selection probability for sampling.** Making this change would increase the probability of selection for stand-alone sites with expected pressures that exceed a certain minimum threshold and decrease the selection probabilities of multi-site clusters formed using the remaining sites. This change could increase the proportion of assignments that obtain at least one interview and also increase the average numbers of fishing trips encountered per assignment.
2. **Consider requiring samplers to obtain counts of all boat trips on which anglers have finished fishing for the day.** The cluster of returning boat trips encountered at a site represents a secondary stage of sampling, and the cluster of anglers who fished on each intercepted boat represent a tertiary stage of sampling. This would

allow determination of appropriate sampling fractions at both the secondary (boat level) and tertiary (angler level) stages of the multi-stage sampling design.

- 3. Consider collecting catch data at the boat trip level rather than at the angler trip level for the boat modes of fishing.** This would eliminate a stage of sampling, thereby reducing both sampling error and the potential for sampler errors (i.e., non-sampling errors) in the selection of boat anglers for interviews.
- 4. Consider including for-hire "guide boats" in the private/rental boat mode instead of the charter boat mode.** For-hire "guide boats" may have more in common with private boats than with charter boats in terms of size, access sites used, transiency, and target species. Adding guide boats to the private boat stratum may address an undercoverage issue associated with these trips and may also increase sampling efficiency.
- 5. Evaluate options for combining boat mode trips (private/rental, guide boats, and charter boats) into a single stratum.** Sites with boat mode fishing activity often include a combination of private boats and for-hire boats. Combining these modes into a single stratum could result in more efficient sampling and fewer assignments resulting in zero intercepts obtained. If needed for management purposes, separate catch estimates could still be calculated for private boat and for-hire sectors by treating these as "domains" within the boat mode stratum.
- 6. Consider implementing more rigorous protocols to ensure random sampling of observed fish for weight and length measurements.** The project team discussed ways to improve the MRFSS sub-sampling fish procedures and developed a more rigorous random sampling protocol that would be feasible for field implementation. We recommend testing of this protocol.
- 7. Consider basing rules for clustering sites more strictly on how geographic strata are defined.** In the Pilot Study, sites were only clustered together if they were within the same county. It would be more appropriate to allow clustering of sites across county boundaries if you are not stratifying sampling by county.
- 8. Evaluate how best to use "confirmed" and "unconfirmed" counts of trips in calculating the secondary and tertiary stage sampling fractions used to weight the data.**
- 9. Consider modifying the rules for clustering sites to use a total fishing pressure threshold as a basis for determining the number of sites in a multi-site cluster.** In the Pilot design, sites below a certain pressure threshold were clustered to form three-site clusters whenever possible. However, creating more two-site clusters would reduce the amount of time spent driving between sites. If a selected two-site cluster exceeds an established total pressure threshold similar to the one

established for stand-alone sites, then it should not be necessary to add a third site to the cluster.

- 10. Evaluate the feasibility of sampling beach/bank shore mode fishing trips in all states using a strict access point survey design as tested in the pilot.** In some states access to this type of shore fishing may be very diffuse, and well-defined access points may be hard to establish. In such cases, a “roving creel” sampling design that allows the collection of data for “incomplete trips” may be necessary.
- 11. Evaluate the possible use of access point survey data to produce estimates of total fishing effort at sites included in the sampling frame.** Although such estimates would be incomplete because they would not account for fishing effort at sites with private access, they could serve as an independent means of monitoring trends relative to those observed in off-site telephone or mail surveys with more complete coverage.
- 12. Consider splitting sites rated to have very high fishing pressure to create more total sites in the highest pressure category.** This could provide more high-pressure alternatives to assign when the number of available days for sampling is limited, such as for weekend assignments.
- 13. Consider conducting separate “frame maintenance assignments” that would survey sites and provide site register updates without attempting to collect any interviews.** Such assignments could be focused on improving the quality of the site register and the accuracy of site pressure ratings. The more accurate the pressure ratings, the more efficient the sampling can become.
- 14. Consider alternative ways to define size measures and weights for sites and site clusters in the sampling frame.** The size measure for a site and time interval could be based on the expected number of fish landed rather than the expected number of angler fishing trips. Consideration should also be given to the categorization of sites with respect to their size measures. More categories or fewer categories may be better than the eight categories used in this study. In addition, more weight could be given to the sites and site clusters with higher pressure estimates in the PPS sampling. As long as lower pressure PSUs have some non-zero probability of being selected, an increase in the inclusion probabilities for higher pressure PSUs would not introduce any bias.
- 15. Consider alternative ways to implement the desired stratification of sampling.** Consideration should be given to using some combination of “explicit” and “implicit” stratification. Explicit stratification creates disjoint subpopulations (in space and time), each of which is allocated a particular sample size and is sampled independently. This explicitly controls sample size within these spatio-temporal

domains. An example of implicit stratification would be systematic sampling of sites within a spatiotemporal stratum after ordering by latitude. The sample size within a given latitude band would not be explicitly controlled, but there would be good representation of sites across latitudes. In particular, it would not be possible to have only southern sites within a latitude band, which could occur by chance without the implicit stratification.

- 16. Consider defining different time intervals for the temporal stratification of sampling in other states.** Time interval sizes and boundaries should be chosen to ensure reasonable sampler productivity while maintaining representative sampling.

## 2. Introduction and Background

An expert review conducted by the National Research Council (2006) identified problems in the Access Point Angler Intercept Survey (APAIS, or intercept survey) that the NOAA Fisheries Service has conducted for many years as a component of the Marine Recreational Fisheries Statistics Survey (MRFSS). The APAIS had been using a stratified, multi-stage cluster sampling design to collect catch data from anglers at fishing access sites, but the current survey estimators and measures of precision did not account for the design complexity. For this reason, the estimators were potentially biased and the measures of precision were overly optimistic. In addition, the data collection protocols for the intercept survey had combined formal randomization with subjective decision-making in ways that further complicated the development of statistically valid, defensible estimators and corresponding measures of uncertainty. Finally, the spatiotemporal sampling frame used for the survey was incomplete and did not provide adequate coverage of angler fishing days ending either on private property or at night.

The Marine Recreational Information Program (MRIP) of the NOAA Fisheries Service initiated work in 2008 to address these concerns with the help of expert consultants. The first project initiated by the Design and Analysis Work Group (DAWG) produced a new weighted estimation method that accounts for the intercept survey sampling design (Breidt, et al., 2011). Some components of the sample weights needed for this method could be calculated directly from available data on sample selection probabilities and cluster sizes, but other components had to be approximated using modeling techniques. The resulting estimator of mean catch per angler fishing day is approximately design-unbiased, and appropriately incorporates the sampling design information as well as the sampling weights. The NOAA Fisheries Service subsequently applied this new method to produce more accurate annual estimates of 2004-2011 total finfish catches for the Atlantic and Gulf of Mexico. The new estimates confirmed that the statistical precision of the intercept survey was worse than previously thought. Although comparisons between the new and old estimates confirmed that the old MRFSS estimators of catch were biased, the magnitude and direction of the bias varied considerably among sampling strata and estimation domains. The net effects on annual estimates of total catch were relatively minor for most fish species, and the previous MRFSS estimates appeared to be consistently biased in one direction for only a small number of species.

Although the implementation of a design-unbiased estimation method was viewed as a very important improvement by the NRC (2006), both Breidt, et al (2011) and Chromy et al (2009) recommended changes to the sampling design of the intercept survey that would address additional NRC concerns about the data collection protocols and temporal coverage of sampling while further improving its statistical validity and accuracy. Breidt et al (2011) noted the new weighted estimation method will only provide correct estimates of mean catch rates “when the sampling, data collection, and data processing for the intercept survey are conducted in accordance with the documented sampling design.” Bias could be introduced into the weighted estimator if the data structure is not arranged to accurately reflect the stratified, probability-proportional-to-size (PPS) multistage sampling design, or if the field samplers misinterpret the sampling and measurement protocols. More formalized sampling protocols with stricter control of sampler behavior are needed to ensure that a probability sample is consistently obtained. Chromy, et al (2009) stressed that “it is necessary to know the probability of selection of each unit (landing site, vessel trip, angler, or fish) interviewed or observed.” Breidt, et al (2011) pointed out that a re-design of the intercept survey would (1) make it much less complicated to determine the true sample selection probabilities, (2) eliminate the need for model-based weighting methods, and (3) provide a means for a strictly design-based approach to unbiased estimation.

To achieve this goal, Breidt et al (2011) made the following recommendations to consider for improving the design of the intercept survey:

1. **The intercept survey should be re-designed to eliminate sampler visits to any sites that are not pre-determined in the probability sampling design.** Breidt, et al (2011) stated, “If clusters of sites were selected as primary sampling units (PSUs) and strict procedures were developed to determine the order and timing of the interviewer’s visits to the assigned sites within the cluster, then the inclusion probabilities of all sites within the cluster would be dictated by the sampling design.” The traditional MRFSS procedure to allow visits to “alternate” sites that were not selected by the sampling design complicates the development of appropriate sampling weights for the angler trip interviews collected at those sites.
2. **More emphasis should be placed on the need to spread out in time the interviews obtained within a selected site-day assignment.** Intercept survey samplers have been encouraged to maximize the number of interviews obtained per hour spent on site. This emphasis has often resulted in samplers making short site visits during



which they intercept a large cluster of angler fishing trips that ended near the same time. It would be more desirable to have angler trip interviews spread across a longer time period so that they could obtain data from more distinct time intervals and/or more distinct boat fishing trips.

3. **If different modes of fishing are sampled as separate strata with their own mode-specific site sampling frames, then opportunistic sampling of fishing trips in a mode other than the one assigned should not be a survey objective.** Breidt, et al (2011) stated, "Alternate mode interviews may be useful for assessing the different kinds of fishing activity that occur at individual sites, but the data collected from such interviews should not be used in the estimation of catch rates when sampling is stratified by mode. The difficulties of determining appropriate inclusion probabilities for alternate mode intercepts will probably always far outweigh any precision benefits that would be gained by trying to include them in the estimation of mode-specific mean catch rates."
4. **A re-designed intercept survey should pay more attention to getting accurate counts of the number of angler fishing trips that are completed within each site-day assignment.** The total count of angler trips, including those not intercepted by the interviewer, plays a very important role in calculating the PSU size measure which determines its selection probability. When conducting interviewing assignments for private boat and charter boat modes for example, it should also be an objective to get an accurate count of all of the completed boat trips so that secondary sampling units (SSUs) cluster sizes can be more accurately quantified. In fact, emphasis should be shifted away from maximizing the number of intercepts obtained per site-day assignment if it interferes with the ability of interviewers to obtain accurate counts of boat trips and angler trips during an assignment.
5. **Consider developing an approach that would cover completed fishing trips throughout the fishing day.** The traditional (MRFSS) sampling procedure instructs interviewers to visit an assigned site during the assigned day's peak activity period for fishing. Consequently, nighttime and off-peak daytime fishing trips are rarely sampled and are implicitly assumed to be similar to trips ending during the peak period. Future surveys could circumvent this potential source of bias by establishing different time block strata so that at least some sampling would occur during nighttime and daytime intervals when fishing occurs.
6. **Focus on maximizing the number of site-days sampled, not the number of angler interviews obtained.** The sampling procedures for the MRFSS have incorrectly focused too much attention on the need to maximize interviews. The total number of intercepts has been considered the "sample size" that needs to be maximized in

order to maximize the statistical precision of MRFSS estimates. The focus should instead be on maximizing the number of site-days sampled, because the primary sampling unit in the multistage intercept survey sampling design is the site-day, not the angler trip and the precision of multi-stage survey estimators depends almost exclusively on the number of primary sampling units.

To respond to these recommendations in a timely manner, the MRIP Sampling and Estimation Work Group began work in 2009 to develop and test an improved sampling design for access point surveys of marine recreational fishing. This work started well before completion of the work to develop the new weighted estimation method for use with current and past intercept survey data. A project team consisting of expert consultants and representatives from NOAA Fisheries and three state agencies was formed to develop appropriate changes in sampling frames, sample selection methods, and on-site sampling protocols that would support a purely design-based estimation approach. The goal was to develop a design in which the sampling protocols are more strictly formalized and subjective decision-making by survey managers and samplers is nearly eliminated. That work led to the development of a pilot study that could be used to test the feasibility of implementing the new sampling design. This report describes the improved sampling design and summarizes the results of a 2010 pilot study conducted in North Carolina to test it and compare its performance with that of the MRFSS sampling design. The comparisons did not aim to evaluate the relative merits of the two designs, but rather to better understand how the changes in the new design would potentially affect sampling efficiency, statistical accuracy, and statistical precision going forward. This information was considered to be useful for assessing any possible needs for further modification that would ensure effective coastwide implementation of the new design.

### **3. Methodology**

#### **3.1 Pilot Survey Data Collection Methods**

Methodological improvements were developed for a new intercept survey design that was tested in comparison with the traditional MRFSS design in a pilot study conducted in North Carolina from January through December 2010. The emphasis here is on describing differences between the traditional MRFSS methods and the new methods

tested in the North Carolina pilot study (Pilot). Methodological changes were implemented in response to both specific NRC recommendations and to address other potential biases or inefficiencies of the old methods identified by the project team. In addition to documenting proposed changes, this section includes rationale for each change and potential issues or trade-offs associated with the new methodology. While methodological changes were extensive, some aspects of the MRFSS methodology remained essentially unchanged (e.g., survey instrument, site fishing pressure categories, angler level trip information etc.). Pilot study methods that remained the same as the MRFSS are not covered in any detail in this document but are described in other reference documents such as the North Carolina Pilot Field Procedures Manual (Appendix A) and the MRFSS 2010 Statement of Work.

Key data collection design changes (described below in more detail) that were implemented in the pilot include:

- 1) Sampling from four fixed 6-hour time intervals covering a full 24-hour sampling day.
- 2) Formalizing a probability-based approach for the selection and order of all sites to visit on a given assignment.
- 3) Clustering of sites for sampling.
- 4) Eliminating opportunistic sampling of alternate modes.
- 5) Attempting to complete all assignments drawn, thus reducing possible bias due to non-observation of selected elements in the sample frame.
- 6) Cancelling assignments that could not be completed rather than re-scheduling, which made it difficult to determine sampling probabilities.
- 7) Improving methods for accurately obtaining counts of eligible angler trips missed, to determine appropriate sampling weights of intercepted trips in the estimation process
- 8) Expanding eligible trip definition to include anglers under five years old and trips at tournament sites.
- 9) Disallowing “incomplete trips” in shore mode, thus eliminating potential bias associated with expanding partial trip catch to represent the entire trip.
- 10) Removing the interview per assignment cap which, when combined with fixed assignment time intervals, should spread the sampling to appropriately represent a larger temporal slice of fishing.

This section is divided into the following subsections: Sampling Methods, Issuing and Completing Assignments, and On-site Interviewing Procedures.

### 3.1.1 Sampling Methods

#### 3.1.1.1 Expanded Coverage and Fixed Time Intervals

This sub-section addresses two important design improvements:

1. Expanded coverage of fishing trips to include trips ending at nighttime and off-peak daytime hours eliminates potential for bias when those trips differ in mean catch rates from trips ending in peak activity periods.
2. Implementation of fixed time-block strata for sampling and fixed time intervals for interviewing makes it easier to determine appropriate cluster sampling weights (at SSU level) to be used in estimation.

In the MRFSS design, samplers determined the start and stop times of each assignment. Samplers were instructed to be at the site during the “peak” hours when most fishing trips would be ending. To remove any sampler discretion regarding selection of assignment times, clearly defined assignment time intervals were used for the Pilot. Historical MRFSS North Carolina data were used to compare trip completion times between the access point intercept survey and Coastal Household Telephone Survey. A six-hour sampling interval was selected as this would allow for a standard eight-hour workday when travel time (to the first site and from the last site comprising a selected cluster) is included. For the Pilot, assignment start and stop times for four distinct 6-hour time intervals were defined as follows:

Interval A: 2AM-8AM  
Interval B: 8AM-2PM  
Interval C: 2PM-8PM  
Interval D: 8PM-2AM

Samplers were instructed to arrive at their assigned site at the start of the assigned time interval and to only conduct interviews within that interval and selected fishing mode. In the event of late arrival, the samplers were instructed to adhere to the original ending time (i.e., they were not allowed to stay late to “make up” for being late). Establishment of assignment time intervals resulted in the following design improvements:

1. Removed sampler discretion regarding sampling times that may lead to biases that are unknown and/or unaccounted for;
2. Removed sampler discretion associated with determining “peak activity” times which resulted in improved Pilot fishing pressure estimates for each particular time interval and weekday/weekend combination;
3. Allowed for a more temporally distributed sample across the day that could be properly weighted using angler counts specific to each time interval;
4. Eliminated potential under-coverage bias from missed fishing activity during “off-peak” sampling times (i.e., night and early morning).

The master site register (MSR), a database of all saltwater recreational fin-fishing locations in each state, is the basis for the sampling frame. In the MRFSS, fishing pressure was estimated for each site, mode, kind of day (weekend or weekday), and wave, and was intended to represent the expected fishing pressure during the peak activity. In the Pilot, the fishing pressures were estimated for each of the four six-hour time intervals. Samplers provided fishing pressure updates only for the specific time interval and assigned mode observed, rather than for some undefined “peak” 8-hour interval as with the MRFSS. This eliminated the guesswork associated with estimating pressures for the whole day that was often a problem under the old approach. Previously, samplers often estimated pressures beyond the amount of time actually spent at a particular site since there was no requirement that the sampler stay on site for any particular amount of time. Table 1 shows the pressure categories and values used in both the MRFSS and Pilot.

**Table 1. Pressure Categories**

Pressure Category	Expected Number of Angler-trips
0	1 – 4
1	5 – 8
2	9 – 12
3	13 – 19
4	20 – 29
5	30 – 49
6	50 – 79
7	80+
8	Unable to determine
9	Mode not present at site or inactive site

### **3.1.1.2. Clustering of Sites**

For the Pilot the maximum number of sites in a given cluster was three. All sites within the cluster had to be visited in the exact order specified during the assignment draw process. In addition, the sample period was set at a maximum of two hours at each site, after which time the sampler was required to move to the next site. For two-site clusters samplers were instructed to spend two hours at the first site, two hours at the second site, and as time allowed return to the first site and sample until the six-hour time interval was up. Two hours duration was maintained at two-site clusters for consistency with three-site clusters. At single site clusters, the sampler remained at one site for the entire 6-hour time interval.

The project team developed the following constraints for clustering:

- Sites with a pressure code of “4” or greater would not be clustered with other sites (i.e. single site cluster);
- Sites with a pressure code of “3” or less could be clustered with up to two additional sites;
- Driving time between any two sites within a single cluster must be less than 60 minutes;

- Total driving time for the entire cluster should be minimized;
- Clusters will contain sites only within the same county (see Regional Stratification in section 3.1.1.5.);
- Sites will be clustered by strata (state subregion/month/mode/time interval) such that all sites within the cluster are required to have positive fishing pressure in that strata. Clusters must be time-interval specific since individual site pressures will vary across intervals (e.g., a high pressure site may be a single site cluster from 2:00PM-8:00PM but clustered with other sites from 8:00PM-2:00AM due to a change in pressure rating).

### 3.1.1.3 Clustering Method

Using the clustering constraints described above, a GIS algorithm was developed based on the concept of “simulated annealing.” Simulated annealing involves establishing certain criteria (desirable or not) and assigning “costs” to those (high or low) depending on their desirability. Simulated annealing attempts to maintain low cost at all times. For the Pilot, desirable attributes included minimizing driving distance between sites within a cluster and maintaining similar size measures (total fishing pressure or effort) across clusters. For example, a desirable clustering attribute such as two sites in close proximity to one another would have a relatively low cost compared to two sites farther apart. Similarly, a non-desirable attribute such as clustering three relatively high pressure sites would have a high cost compared to clustering a relatively high pressure site with two very low pressure sites. The algorithm developed identifies many possible clustering combinations and then ranks them such that the combination with the most desirable attributes (i.e. “lowest total cost”) can be identified. High activity sites (fishing pressure 4 or greater) were automatically identified as single site clusters. Since fishing pressures are not static across waves and modes, cluster combinations also changed across waves and modes. For example, two sites may be in the same cluster during Wave 3 but not Wave 4. Similarly, two sites may be clustered for Charter boat mode assignments but not for Private Boat mode assignments.

The result is a list of clusters, each containing anywhere from 1 to 3 sites, with minimized “cost” (i.e. meeting the constraints). Project team members with considerable knowledge of North Carolina’s fishing sites thoroughly reviewed and evaluated all clusters before each sample draw. Site cluster maps were produced for each cluster identified for sampling (Appendix B).

### 3.1.1.4 Formalized Probability Sampling of Sites

A new selection procedure was developed that pre-determined all site assignments through the sample draw process. Interviewers were required to collect data at a selected site for a specified time interval and were not allowed discretion regarding when to leave a site or which site to visit next.

### 3.1.1.5 Regional Stratification

For the Pilot, the project team tested regional stratification within North Carolina. North Carolina's coastal zone was divided into three subregions (Northern, Central, and Southern) using county boundary lines based on existing state and federal fisheries management units as well as recreational fishing and geographic diversity (Figure 1).

**Figure 1 Survey subregions and fishing access sites used for the NC Pilot Project**

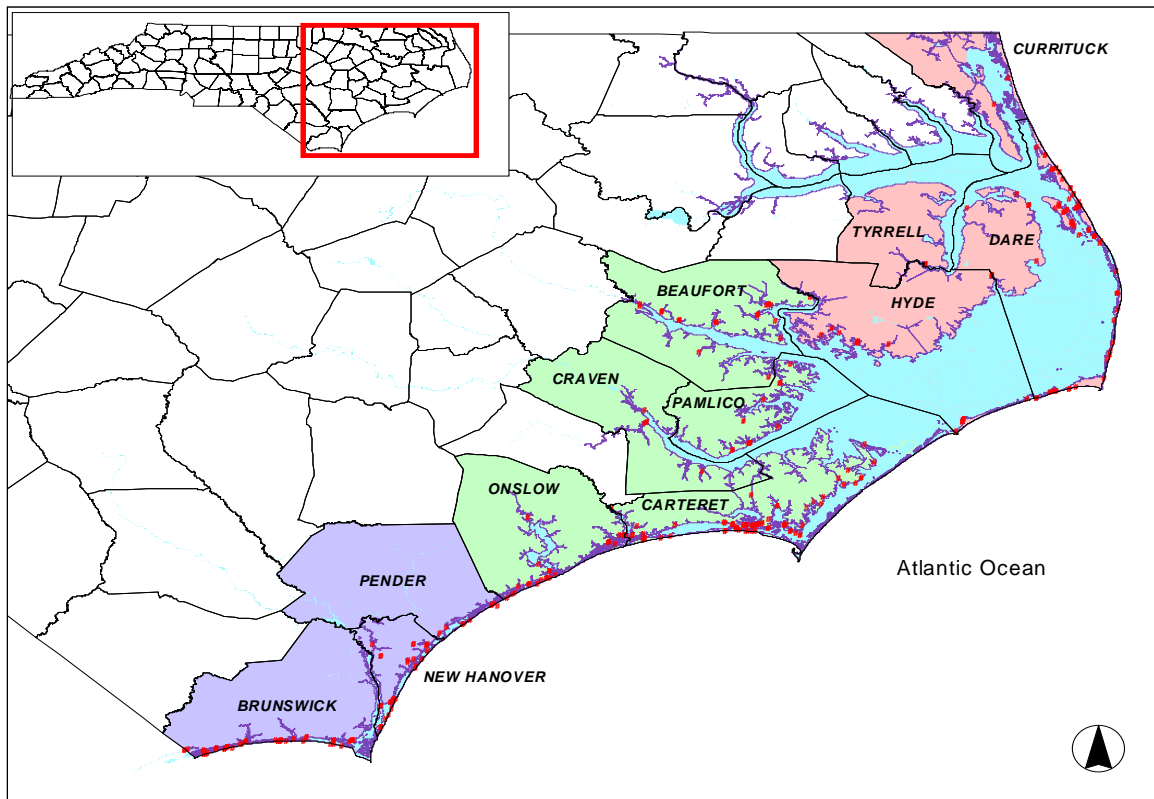



### 3.1.1.6 Sample Size and Allocation

Under the MRFSS intercept design, “sample size” referred to the total number of completed interviews obtained. Specific sampling goals or quotas were established for each strata and attainment of these goals was closely managed and monitored by contractors, state agencies and NOAA Fisheries. By contrast, for the Pilot study design, the effective sample size was defined as the total number of assignments completed or PSUs rather than the number of interviews obtained.

The total number of interviewing assignments to be selected for the Pilot was determined by the number of samplers available for the Pilot and the number of working days allowed per sampler. From January through September, 6 samplers were available for the Pilot with two samplers being assigned to each state subregion. Samplers were limited to one assignment per day for the Pilot. Since each sampler was available to work a maximum of 12 weekday days and 8 weekend days per month, the maximum number of monthly assignments per state subregion was 24 for weekdays and 16 for weekend days. Ten samplers were available for October through December, with corresponding increases in the number of maximum assignments.

For the Pilot, assignments were allocated evenly across the four modes in each state subregion: Man-made (MM), Beach Bank (BB), Private/Rental (PR), and Charter (CH). Allocation of mode-specific assignments within each state subregion and day type (i.e. kind of day) was determined monthly.

In the initial Pilot allocation a minimum of one PSU was sampled from each interval, resulting in at least two night interval assignments (A: 8PM – 2 AM & D: 2AM – 8 AM) selected for every month, mode, state subregion, and day type. The only exception was if there was no night fishing activity for a particular stratum. This allocation resulted in a much higher proportion of night time interval assignments selected than was warranted based on fishing pressures. With 4 modes, 3 state subregions, and 2 night time intervals the number of night time interval assignments per months can add up quickly (i.e.,  $4 \times 3 \times 2 = 24$ ). While the actual number of night assignments selected was less than this number (i.e., not all combinations had night activity) the proportion of night assignments was still quite large in many months. For example, 34 out of a total 118 assignments (29%) drawn in May were night time interval assignments. It is anticipated that night time interval (A & D) fishing pressure estimates will improve over time once the new design is fully implemented.

To resolve the issue of night assignments being drawn too frequently, the two night intervals (A & D) were combined into one stratum for sampling purposes starting with the June sample draw. Although the two night-intervals were combined, no PSUs were removed from any of the intervals. This approach allowed for probability sampling within the combined night interval that more closely reflected the estimated pressures while still assuring that some minimal number of night assignments was drawn within each month, mode, and state subregion.

In the first five months, a minimum of one assignment was drawn and completed for each of the sampling strata under the new design, resulting in at least two night interval assignments selected for every month, mode, state subregion, and day type. The only exception was if there was no night fishing activity for a particular stratum. Starting in June, the two nighttime blocks were combined into one “nighttime” stratum requiring the minimum of one interviewing assignment.

### **3.1.1.7 Sample Frame and Assignment Draw**

The North Carolina Pilot sample frame consisted of all possible combinations of clusters, calendar days, and time intervals within a given stratum, i.e. month/mode/kind-of-day/state subregion combinations. The D: 8PM-2AM time interval extends over two calendar days. For purposes of the draw, the Friday 8:00 PM to Saturday 2:00 AM time interval was considered a “weekend” assignment while the Sunday 8:00 PM to Monday 2:00 AM interval was considered a “weekday” assignment in the pilot.

The total pressure for a cluster was defined as the sum of individual site pressures calculated as the midpoint of the pressure category range. For example, if a pressure category 1 site (5-8 angler trips) is clustered with a pressure category 3 site (13-19 angler trips) the cumulative cluster pressure is 22.5 (6.5 + 16). The interval weights were calculated as the inverse of total cluster pressure for each state subregion and kind of day. Probability proportional to size (PPS) systematic sampling was used to select a random sample of assignments for each state subregion.

Several logistical constraints related to sampler availability were incorporated into the assignment draw process:

- No more than two day interval (B or C) assignments (PSUs) could be selected on the same day in a given state subregion, since only 2 samplers were available per state subregion.

- Single-site cluster assignments with pressure codes of five or higher required two samplers, one to conduct interviews and one to count angler trips.
- Eight or more hours of employee rest between assignments were required by state labor regulations. For example, if time interval A: 2AM-8AM on June 4<sup>th</sup> is assigned to a sampler, that sampler cannot be issued the two intervals before the assignment (C: 2PM-8PM or D: 8PM-2AM on June 3<sup>rd</sup>) or two intervals after the assignment (B: 8AM-2PM or C: 2PM-8PM on June 4<sup>th</sup>).
- For safety reasons, an assignment in either of the night intervals (A: 2AM-8AM or D: 8PM-2AM) required two samplers working together in the field. Therefore, no more than one night interval assignment could be selected within a 12 hour period (i.e., two intervals) in a given state subregion since only 2 samplers were available per state subregion.
- Samplers cannot work more than 40 hours per week, including travel and editing time.

The Pilot study assignment schedule process maximized the number of assignments that could be completed by the relatively small number of samplers.

### 3.1.2 Issuing and Completing Assignments

The issuing of assignments in the Pilot differed from the MRFSS in several important ways. The MRFSS draws three different kinds of assignments in hierarchical order of importance: 1) fixed - must be issued, 2) flexible – must be issued only until the interview goal is attained for a particular stratum, and 3) reserve – only issued if anticipated that the interview goal cannot be attained with fixed and flexible assignments alone. By contrast, all drawn Pilot assignments had the same importance and were issued.

All Pilot assignments that were drawn (i.e., issued) had to either be completed or cancelled since rescheduling was not allowed. As discussed above, sampler discretion regarding sites visits (i.e., order, duration, exact time start and stop times) was removed for the Pilot. For multi-site clusters the site visitation order was circular (e.g., ABC, ABC... as time allows within the 6-hour interval) and the starting point was randomized prior to assignment.

### 3.1.3 On-Site Interviewing Procedures

Pilot survey samplers only conducted Pilot assignments to avoid confusion with MRFSS procedures. A more detailed description of the Pilot field interview procedures, including procedures that remained the same as those followed by MRFSS samplers, can be found in the NC Pilot Field Procedures Manual (Appendix A).

#### 3.1.3.1 Definition of an Eligible Angler Trip

The NRC report identified several potential under-coverage biases associated with the MRFSS intercept survey criteria for defining an eligible angler trip. The Pilot attempted to address these and other potential coverage biases through the following design changes regarding the definition of an eligible angler trip:

1. Anglers Under 5 Years Old

Anglers under 5 years of age are excluded from the MRFSS Intercept survey as ineligible, though they are tallied on the Assignment Summary Form. In the Pilot all anglers, regardless of age, were eligible to be interviewed either in person or through proxy interviews, as was the case with very young anglers.

2. For-Hire Captains and Crew

Similar to the MRFSS, Pilot survey samplers did not count the captain and crew as contributors since they were technically not fishing recreationally and their trip would not be reported as recreational trips in the For-Hire phone survey. However, unlike in the MRFSS, Pilot samplers were instructed to include any catch by the captain and crew that was mixed in with the observed catch (Type A catch) recorded for a group of charter boat anglers.

3. Tournament Trips

For the Pilot, there was no tournament restriction in place and samplers were instructed to stay and interview at tournament weigh station sites if they were part of the assigned cluster. Pilot samplers were reminded that they should not station themselves in locations that only anglers with catch would visit (e.g. the cleaning station or weigh station) as this could bias catch rates, particularly at tournament settings. A question was added to the Pilot intercept form (to be asked of every

person interviewed) as to whether or not the angler fished in a tournament that day. In addition, samplers were instructed to record whether or not the site was an official tournament weigh-station for that assignment on the Assignment Summary Form (ASF).

#### 4. Incomplete Trip Interviews

To increase intercept productivity, MRFSS procedures allow for up to half (50%) of intercepts for a beach/bank (BB) mode assignment to be conducted with anglers who are at least 1/3<sup>rd</sup> done with their fishing trip (i.e., “incomplete trip” interviews). The determination of whether 1/3<sup>rd</sup> of a trip is complete is based on asking the angler how much longer they intend to fish. Incomplete trip interviews were seen as a way to increase BB productivity because 1) BB anglers tend to fish longer periods of time than in other modes (i.e. beyond the constraints of a typical work day) and 2) at some BB sites anglers are spread out across a large distance and use multiple points of egress making it difficult for a sampler to intercept completed trips. MRFSS catch rates during the completed portion are then extrapolated to the uncompleted portion of the trip for estimation purposes. However, this will likely biased survey estimates of the length of the fishing trip, since the assumption catch rates for the completed portion are the same as catch rates for the uncompleted portion may be erroneous. To eliminate this potential bias, incomplete trip interviews were not allowed in the Pilot.

#### 3.1.3.2 Angler Trip Counts (SSU Cluster Sizes)

A “missed eligible” is an angler trip that was likely eligible to be interviewed, but was not due to the sampler already interviewing other anglers or some similar situation. Two main types of “missed eligible” trips were identified: 1) “Confirmed” trip - sampler was able to “screen” the angler (i.e. to speak with the angler to verify the angler fished recreationally, was targeting finfish, fished in U.S. waters, and was done fishing in that mode for that day), and 2) “Unconfirmed” trip - unable to screen the person because they left the site while the sampler was busy interviewing, screening other anglers or the sampler was otherwise unable to approach the person.

For the Pilot, samplers were instructed to attempt to screen people on all vessels, including canoes, kayaks, and even jet skis, to confirm whether or not they fished that

day. In addition, people who appeared to be shellfishing or lobstering were also screened to confirm that they did not target or incidentally catch a finfish.

The distribution of the type of “missed eligible” (confirmed versus unconfirmed) tallied was expected to be correlated with the level of fishing activity at a site on a particular day. That is, if there is little activity at a site it should be relatively easy to either interview all eligible anglers or count the few anglers that were not interviewed. By contrast, if there are many boats returning at the same time or many shore anglers leaving the site at the same time the accuracy of angler counts will likely diminish and it may not be possible to screen everyone leaving the site (i.e., the proportion of “unconfirmed” trips will tend to increase). For the Pilot, to maintain a high level of accuracy in these situations, two samplers were assigned to sites with a pressure category of 5 (30-49 anglers) or higher. One sampler conducted interviews while the other conducted angler counts and attempted to confirm eligible angler trips by screening anglers whenever possible. To avoid double counting trips, the sampler doing the counts did not include interviewed anglers. At no time did both samplers engage in the same activity at the same time. The two samplers worked together to fill out one assignment summary form (ASF) for the assignment. Similar procedures for splitting counting and interviewing between two samplers were used for all night assignments (i.e. Intervals A and D).

Procedures were also changed in the Pilot to improve the accuracy of angler trip counts for assignments with only one sampler (i.e., pressure category 4 or less). Under normal circumstances, one sampler should be able to interview all (or virtually all) eligible anglers in the assigned mode at pressure category 4 (20-29 anglers) or smaller sites, and screen any anglers that could not be interviewed. However, on any given day fishing activity level may be higher than expected making it difficult to simultaneously conduct interviews and obtain accurate counts. The physical layout of the site (e.g., size, number of egress points) may also be a factor affecting the ability to conduct interviews and accurate counts simultaneously. If the sampler determines that fishing activity is such that they cannot effectively interview and count at the same time they should alternate between conducting interviews and conducting counts, in one hour increments for the time they are supposed to be at that site. Samplers recorded the survey method used (1=interview, 2=count, 3=both simultaneously) and the start and stop times for each method used at each site on the ASF. Since some time will be dedicated to counting and not interviewing, a reduction in the number of interviews per assignment was expected with these procedural changes.

### 3.1.3.3 Intercept Limit per Assignment

Under MRFSS intercept procedures, an upper limit was placed on the number of intercepts a sampler could obtain per assignment: 20 intercepts per assignment from Maine through Virginia; 30 intercepts per assignment from North Carolina through Louisiana. The limit served to more evenly distribute intercepts over more assignments so that a few assignments with a lot of intercepts would not fill the intercept quota for a particular wave/state/mode combination, and thus heavily influence catch rates in that stratum. These concerns were not an issue for the Pilot, since sampling goals or quotas were defined in terms of site-days rather than interviews completed and appropriate weighting of Catch Per Unit Effort (CPUE) data eliminates concerns about over-sampling a given site/day combination. Therefore, for the Pilot there was no limit on the number of intercepts that could be obtained per assignment.

### 3.1.3.4 Form Changes for Pilot

With the exception of the question added for tournament trips (3.1.3.1) the intercept survey form used for the Pilot matched that used in the MRFSS. More changes were made to the Assignment Summary Form (ASF, Appendix C) and Site Description Form (SDF, Appendix D) to accommodate new field procedures implemented in the Pilot. These changes are summarized below.

Assignment Summary Form changes:

- Added box to record second sampler code to be used for night assignments and pressure category 5 or greater assignments;
- Added boxes to record total “confirmed” and “unconfirmed” numbers of angler trips and start and stop times associated with these counts. Note: “confirmed” and “unconfirmed” boxes replaced boxes for “missed” at bottom of MRFSS ASF;
- Provided boxes to tally counts of “confirmed” and “unconfirmed” angler trips and refusals and language barriers;
- Added box to indicate the survey activity: 1 = interviewing, 2 = counting, and 3 = both simultaneously;
- Added box to indicate whether or not the site was a tournament weigh station;

- Added box to record the assignment cluster identification number;
- Reason codes for leaving a site were expanded to include: 1) two hour time interval ended, 2) six hour assignment time interval ended, 3) site closed (after hours), 4) site closed (other specify), 5) site unsafe during sampling period;
- The following reason codes for leaving site were removed as they no longer applied under the new procedures: 1) no activity in mode (weather unfavorable), 2) no activity in mode (weather favorable), 3) fewer than eight intercepts in mode, 4) got quota in mode, 5) tournament weigh station.

#### Site Description Form changes:

- Added box to record second sampler code to be used for night assignments and pressure category 5 or greater assignments;
- Since weather can greatly affect the fishing pressure for a given day, check boxes were added to record more detailed weather information than previously recorded. Wind speed is now recorded by category using a scale ranging in knots (e.g., breezy = 1 to 16 knots, windy = 17-33 knots etc.). This type of detailed information may be useful for adjusting for weather when setting site pressures;
- Added area to record site latitude and longitude to improve the information on the site register and make it easier for samplers to locate a site, and to verify that they are in the right location;
- Added boxes to indicate whether or not night fishing is present for all modes, not just shore (SH) and private/rental (PR) as was previously done.
- For the Pilot, samplers were asked to estimate fishing pressure only for the particular mode and six-hour time interval of the assignment for both weekend/weekday and both months of the current wave. This is different from MRFSS, where pressure was estimated for all modes and “peak productivity” (morning, mid-day, afternoon, night) was also recorded.



## 3.2 Methods used for Data Analysis and Examination of Differences in Sampling Yield, Estimators, and Statistical Precision

### 3.2.1 Sampling Yield

Several measures were selected to examine differences in sampling yield between the MRFSS and Pilot sampling designs. These metrics included: 1) average number of intercepts per assignment, 2) average number of intercepts per hour, 3) average number of anglers (interviewed or missed) per assignment, 4) average number of sites visited per assignment, and 5) the ratio of actual time on site versus recorded site hours (including travel time between sites). Time of intercept was also examined to determine the number of intercepts obtained through the Pilot during times not typically surveyed in the MRFSS. Finally, the average numbers of fish reported and observed were compared between surveys for selected common fish species.

Because MRFSS sampling locations consist of both locations randomly selected using a probability sampling design (i.e. primary sites) and locations chosen by samplers (i.e. alternate sites), two sets of measurements were produced for MRFSS when possible for comparison with the Pilot. Difference between methodologies for each metric was calculated as the percent change from MRFSS to Pilot.

Because staffing levels and number of completed assignments differed between the MRFSS and Pilot surveys, all metrics presented use either averages (e.g. intercepts per assignment or per hour) or ratios to allow for more meaningful comparisons.

### 3.2.2 Comparisons of Survey Estimates

For each estimate, a 95% confidence interval (CI) was calculated as the estimate plus and minus 1.96 times the standard error. The CIs may not be valid for some estimates due to sparse or skewed distributions caused by small sample size. The degree of confidence interval overlap was used to informally assess differences between estimates. Note that statistical significance does not imply biological or management significance. Four degrees of overlap were considered:

- Case 1 - Estimate of Method B falls within Method A confidence interval and estimate of Method A falls within Method B confidence interval

- Case 2 - Estimate of Method B falls within Method A confidence interval or estimate of Method A falls within Method B confidence interval
- Case 3 - Neither estimate falls within the other confidence interval, however the confidence intervals do overlap
- Case 4 - The confidence levels do not overlap

**Table 2. Illustration of four outcomes (cases) for comparison of survey estimates.**

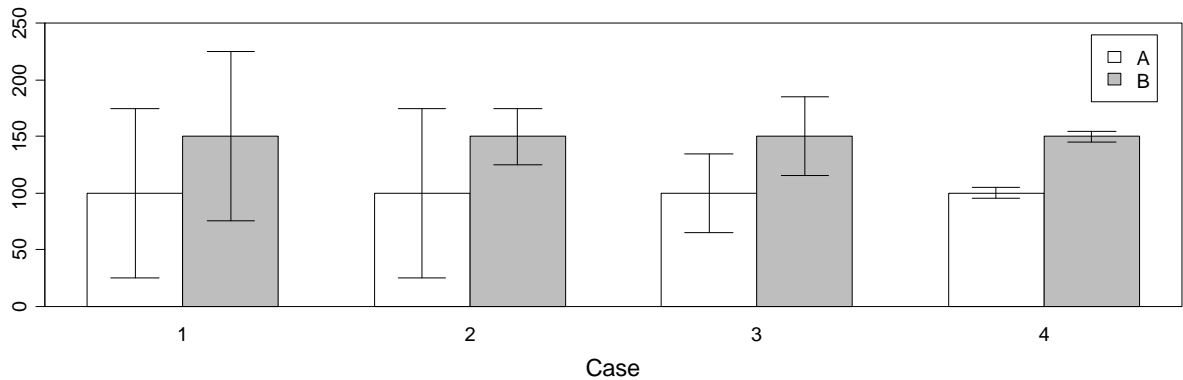

### 3.2.3 Comparison of the Statistical Precision of Estimators

In order to evaluate the expected precision of the new sampling design relative to that of the MRFSS design, we considered estimation of the total catch across all species and types of catch, and estimated the relative efficiency of the two designs. Relative efficiency of the Pilot is defined as the ratio of the estimated variance for MRFSS to the estimated variance for the Pilot. Therefore, relative efficiencies greater than one favor the Pilot design.

Before computing the relative efficiencies, we needed to make the two designs as comparable as possible. Since MRFSS did not contain night-time assignments, we only considered the day-time assignments for the Pilot. The remaining sample size in the Pilot was substantially lower than that of the MRFSS, both overall and in most of the strata, so that a direct efficiency comparison is not appropriate. Our approach consisted of estimating the variance for a “hypothetical Pilot” sample design that has the same sample size and distribution of sample among fishing mode and geographic strata as was obtained with the MRFSS design in the pilot study.

We considered four scenarios, depending on whether we used all the MRFSS site data (both primary site data and alternate site data) or only the primary site data, and

depending on whether we used the same sample allocation (among mode strata) as in the MRFSS or optimized the allocation in the Pilot. For the optimal allocation, the overall sample sizes are equal for MRFSS and the hypothetical Pilot, but the stratum allocation of the Pilot is chosen to minimize the variance of estimated total catch.

## 4. Results and Analyses

### 4.1 Sampling Yield

Table 3 below shows a monthly comparison of the total number of assignments completed, total number of sites visited, and total number of intercepts obtained in the MRFSS and the Pilot, respectively. For comparison purposes, it is important to note that in the MRFSS there were 12 samplers in January and 15 samplers in February through December. In the Pilot study, there were 6 samplers from January through September, and 10 samplers from October through December.

**Table 3. Total number of assignments completed, number of sites visited, and number of intercepts obtained by survey (MRFSS and Pilot)**

<b>MRFSS</b>	<b># of assignments completed</b>	<b># of sites visited</b>	<b># of intercepts</b>
<b>January</b>	154	409	244
<b>February</b>	139	352	235
<b>March</b>	205	516	685
<b>April</b>	159	362	1307
<b>May</b>	218	423	2384
<b>June</b>	223	405	2777
<b>July</b>	216	407	2887
<b>August</b>	237	429	2957
<b>September</b>	220	475	2677
<b>October</b>	246	459	2892
<b>November</b>	179	319	965
<b>December</b>	170	400	290
<b>TOTALS</b>	2366	4956	20300

<b>Pilot</b>	<b># of assignments completed</b>	<b># of sites visited</b>	<b># of intercepts</b>
<b>January</b>	64	161	70
<b>February</b>	61	149	89
<b>March</b>	61	144	116
<b>April</b>	69	172	260
<b>May</b>	64	162	379
<b>June</b>	62	149	511
<b>July</b>	59	144	516
<b>August</b>	61	139	472
<b>September</b>	62	154	339
<b>October</b>	70	172	450
<b>November</b>	91	230	356
<b>December</b>	98	248	58
<b>TOTALS</b>	822	2024	3616

MRFSS samplers visited fewer sites per assignment (2.09) than Pilot samplers (2.46). Under the MRFSS sampling design, 36.7% of the interviewing assignments visited only one site, 19.5% visited two sites, and 43.8% visited three sites. Under the Pilot sampling design, 12.2% of the assignments visited only one site, 32.4% visited two sites, and 55.4% visited three sites.

The total number of completed assignments or Primary Sampling Units (PSUs) obtained for the MRFSS was larger than for the Pilot (Table 4). By contrast, the Pilot had a much larger percent of assignments that resulted in no intercepts (“empty PSUs”) compared to the MRFSS. More than one-half of all Pilot PSUs were “empty.”

**Table 4. Total number of Primary Sampling Units (PSUs) visited by mode and survey (MRFSS and Pilot)**

WAVE	Beach Bank				Man-Made			
	Pilot PSUs	Pilot % Empty	MRFSS PSUs	MRFSS % Empty	Pilot PSUs	Pilot % Empty	MRFSS PSUs	MRFSS % Empty
1	30	73.3	59	67.8	45	88.9	0	0
2	40	50.0	87	43.7	41	48.8	56	17.9
3	43	25.6	97	20.6	41	4.9	77	6.5
4	33	39.4	103	13.6	41	4.9	86	7.0
5	44	40.9	117	11.1	38	10.5	104	8.7
6	61	60.7	118	38.1	50	48.0	91	36.3
<b>All Waves Combined</b>	251	48.2	581	29.3	256	35.9	414	15.2

WAVE	Private/Rental				Charter			
	Pilot PSUs	Pilot % Empty	MRFSS PSUs	MRFSS % Empty	Pilot PSUs	Pilot % Empty	MRFSS PSUs	MRFSS % Empty
1	62	62.9	137	67.2	29	86.2	97	84.5
2	47	51.1	159	45.9	43	76.7	106	67.0
3	48	33.3	231	16.0	35	48.6	90	26.7
4	44	22.7	255	11.0	43	48.8	72	19.4
5	46	45.7	253	22.5	42	78.6	81	46.9
6	69	58.0	126	36.5	55	89.1	95	71.6
<b>All Waves Combined</b>	316	47.5	1161	28.7	247	72.1	541	54.9

Table 5 displays average values and percent change calculated for several measures, by survey and fish mode. Percent change was calculated as the Pilot measure minus the

MRFSS measure divided by the MRFSS measure (i.e., a negative percent change means that the MRFSS measure exceeded that of the Pilot).

The greatest differences in the number of intercepts obtained per assignment occurred in beach/bank (-67%) and charter boat (-65%) fishing modes (Table 5). Although differences were not as pronounced, similar results were found when comparing the number of intercepts from MRFSS primary sites with the Pilot survey (not shown in table). Geographically, the Southern region of North Carolina exhibited the smallest difference in the number of intercepts per assignment between MRFSS and Pilot for all modes except charterboat (not shown in table). Overall, across modes, the largest difference in the number of intercepts per assignment was observed in the Northern region.

Similarly, the greatest differences in the number of intercepts obtained per hour were observed for the beach/bank (-80%) and charter boat (-81%) fishing modes. Comparisons of the number of intercepts per hour at MRFSS primary sites with the Pilot survey resulted in similar differences across all modes. Overall, across modes the Northern region revealed the largest difference in the number of intercepts obtained per hour.

The greatest differences in the number of angler trips counted (interviewed plus missed) per assignment occurred in beach/bank and charter boat fishing modes (Table 5). Geographically, the Southern subregion of North Carolina exhibited the smallest difference between MRFSS and Pilot methodologies for all modes except charterboat. Overall, across modes, the Northern subregion generally revealed the largest difference in the number of angler trips counted (interviewed plus missed) per assignment.

Figure 2 displays the average number of intercepts per two-hour time period for both surveys methodologies. Higher numbers of intercepts were observed for pre-dawn hours for private boat and man-made fishing modes for the Pilot compared to MRFSS. The Pilot survey also had higher average intercepts from 6:00 pm through 12:00 am for the private boat mode and 11:00 pm – 12:00 am for the beach/bank mode (Figure 2).

**Table 5. Percent change of average values by measure, study and fishing mode.**

Measure	Mode of Fishing	MRFSS	Pilot	% Difference Pilot versus MRFSS
Average intercepts per assignment	Beach/Bank	7.58	2.48	-67.28%
	Private boat	6.98	3.61	-48.28%
	Manmade	11.71	5.97	-49.02%
	Charter boat	5.59	1.95	-65.12%
	All Modes	7.56	3.44	-54.50%
Average intercepts per hour	Beach/Bank	2.12	0.42	-80.19%
	Private boat	1.54	0.6	-61.04%
	Manmade	3.35	0.99	-70.45%
	Charter boat	1.69	0.32	-81.07%
	All Modes	1.97	0.57	-71.07%
Average angler trip count per assignment (intercepted + missed)	Beach/Bank	8.68	2.53	-70.85%
	Private boat	9.35	3.61	-61.39%
	Manmade	13.97	5.97	-57.27%
	Charter boat	8.35	1.95	-76.65%
	All Modes	9.71	3.45	-64.47%

**Figure 2. Average number of intercepts obtained per two-hour intervals for each mode and survey methodology.**

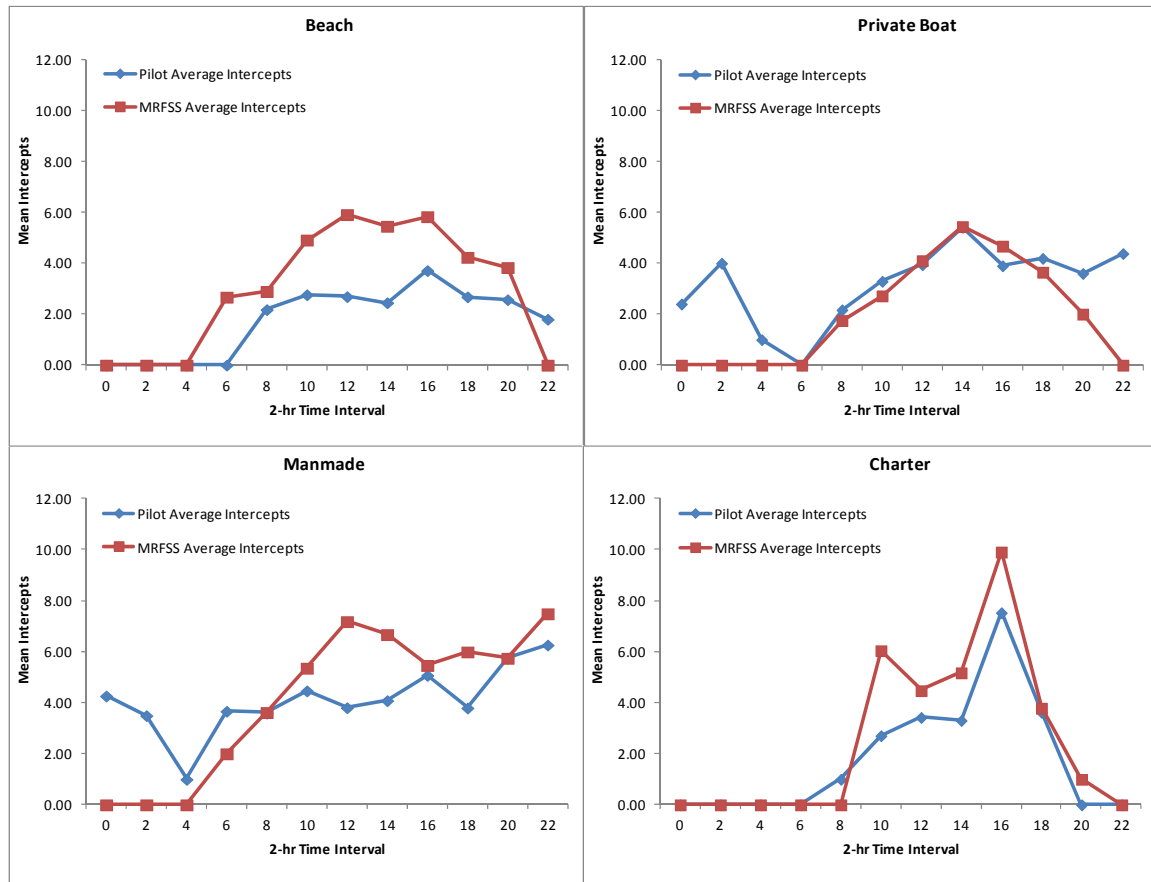

Within MRFSS, man-made intercepts were collected over a 17 hour time frame (7:00 am through 11:59 pm), beach/bank intercepts over 14 hours (7:00 am through 8:59 pm), and charterboat and private boat intercepts were collected over a 12-hour time frame (10:00 am through 9:59 pm and 9:00 am through 8:59 pm, respectively). The Pilot expanded intercept collection times to 24 hour coverage for man-made, beach/bank, and private boat modes. Charterboat was sampled over a 12-hour duration (8:00 am through 8:00 pm). Expansion of coverage resulted in 3.94% of man-made intercepts and 3.23% of beach/bank intercepts to be obtained outside of the time periods sampled by MRFSS. The private boat mode exhibited the greatest percentage (6.2%) of intercepts collected outside of times sampled through MRFSS. The graphs of intercepts obtained per hour through MRFSS tended to exhibit taller peaks restricted to daylight hours compared to the Pilot graphs which exhibited compressed or “shorter and wider” curves

with intermittent fluctuations (Figure 3). The jagged curve for the Pilot in the shore modes (Figure 3) likely reflects times of day spent traveling from one site to another within a multi-site clusters. For example, for an 8:00 AM – 2:00PM assignment time-interval samplers would always be traveling from the first site to the second site at 10 AM and from the second site to the third site (or back to the second site) at 12 PM. Therefore, as reflected by the dips in the graphs, fewer intercepts were obtained in these hourly intervals since more time was spent traveling to the next site.

**Figure 3. Frequency of intercepts per hour obtained from MRFSS and Pilot**

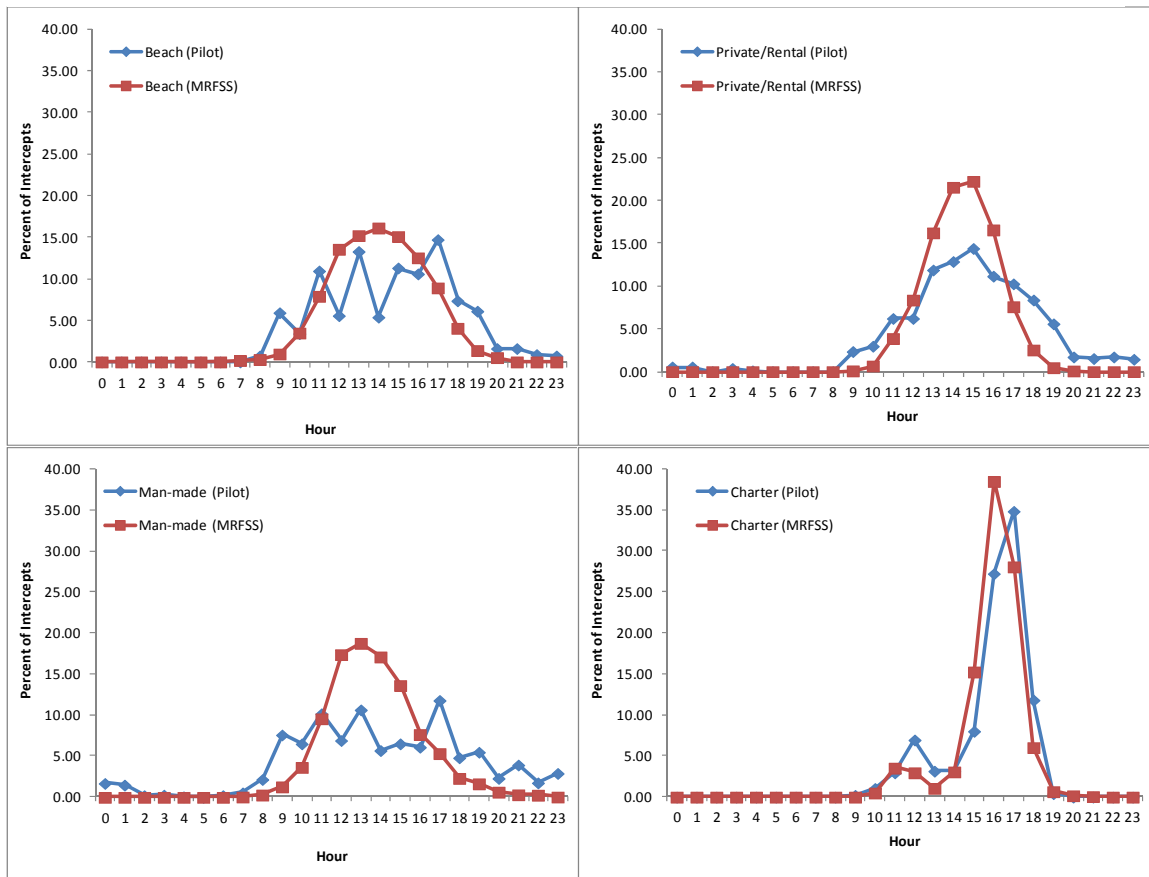



Eight species (or species groupings) were selected for comparing the average number of fish caught per assignment between the MRFSS and Pilot surveys (Table 6). These species (or groups) were selected because they are highly targeted by North Carolina anglers, or they are caught in large numbers, or both. Comparisons were made for both “reported” fish that were unavailable for inspection by the sampler, and for “observed” fish that were seen by the sampler. "Reported" includes a combination of released fish and landings. Comparisons were made only between positive assignments where at least 1 fish of that species was caught (i.e., zero catch assignments were not included in the analysis). The average numbers of reported Atlantic croaker, kingfishes, red drum, and spotted seatrout were greater in the Pilot compared to those reported in the MRFSS and slightly less for bluefish, dolphin, and flounder. The average numbers of fish observed were higher for bluefish, dolphin, flounder, and spotted seatrout under the MRFSS sampling design but the average numbers observed were higher for croaker, kingfish, and red drum under the new sampling design.

**Table 6. Average numbers of fish reported and observed, and percent change by species and survey.**

Species	Average Number Reported			Average Number Observed		
	MRFSS	PILOT	% Change	MRFSS	Pilot	% Change
Croaker	4.67	5.66	21.20	4.94	6.63	34.21
Bluefish	3.71	3.60	-2.96	5.78	4.19	-27.51
Dolphin	5.09	4.92	-3.34	18.99	13.46	-29.12
Kingfish Genus	3.68	5.49	49.18	4.28	7.60	77.57
Lefteye Flounder Genus	2.96	2.82	-4.73	2.16	2.04	-5.56
Red Drum	2.47	3.40	37.65	1.33	1.38	3.76
Spotted Seatrout	6.40	10.45	63.28	2.67	2.55	-4.49

## 4.2 Comparison of Pilot and (weighted) MRFSS Effort and Catch Estimates

The MRFSS access point survey data is used to estimate two important estimation parameters – the mean catch per angler trip and the proportion of angler trips made by coastal county residents with landline phones. The inverse of the latter estimated proportion is used to expand the Coastal Household Telephone Survey (CHTS) estimate of fishing effort to account for anglers that cannot be reached by the CHTS (i.e., non-coastal or no landline phone). The mean catch per angler trip for each finfish species is

multiplied by the estimated total number of angler trips to get an estimate of the total catch of that species. Catch and effort estimates were compared between the Pilot and MRFSS. Appropriate weighting techniques were used to calculate both the Pilot and MRFSS estimates used for comparisons. North Carolina Pilot and MRFSS effort estimates were based on the same primary data sources: the Coastal Household Telephone Survey for private boat and shore modes, and the For-Hire Telephone Survey for charter boat mode. As a result, overall effort estimates were expected to be reasonably close to one another with differences being attributed to intercept survey coverage correction factors: i.e., out-of-state and non-coastal component adjustments and charter boat off frame adjustments. Differences in estimates of the proportion of trips by fishing area (ocean within 3 miles, ocean outside of 3 miles, and inland) would also be attributed to intercept survey data.

The 2010 total effort (angler trips) estimate was 4,852,349 for the Pilot and 5,677,574 for (weighted) MRFSS, with overlapping 95% confidence intervals. Nearly two-thirds of this difference was due to the beach/bank mode where effort estimates were 1,370,981 trips in the Pilot and 1,930,919 trips in the MRFSS. This difference was due to differences between the MRFSS and the Pilot in the percent of beach/bank mode intercepts conducted with coastal county residents (Table 7). However, the estimated proportion of beach/bank mode trips by fishing area did not differ between the Pilot and MRFSS.

**Table 7. MRFSS and Pilot percent of beach/bank mode intercepts with coastal residents by wave.**

Mode	wave	Pilot % coastal	MRFSS % coastal
BB	1	0.8455	0.6575
BB	2	0.3502	0.3339
BB	3	0.5252	0.3715
BB	4	0.5611	0.3614
BB	5	0.5317	0.3501
BB	6	0.4152	0.3997

There is some suggestion that the coastal resident proportion difference in the beach/bank mode could be linked to the elimination of incomplete trip interviews or the inclusion of nighttime sampling under the new design, but it was not possible to show a statistically significant differences in this proportion between complete and incomplete trip interviews or between nighttime and daytime trip interviews under the MRFSS

design in this study. The possibility of a length of stay bias under the MRFSS design warrants further study.

Pilot catch estimates were compared to revised (weighted) MRFSS catch estimates for 15 important management species. Overall, no clear trends or systematic differences were found when comparing either landings estimates or released alive estimates for all modes combined; i.e. in some cases Pilot estimates were higher, in others, MRFSS estimates were higher. With all waves and modes combined, Pilot landings estimates were higher than MRFSS for 7 out of 15 species, while Pilot released estimates were higher than MRFSS for 8 out of 15 species (Figures 4&5).

Ninety-five percent confidence intervals were calculated for Pilot and MRFSS estimates to compare overlap and detect statistical significance. Confidence intervals overlapped for 13 out of 15 landings estimates comparisons (Figures 4a, 4b, and 4c) and also for 13 out of 15 released estimates comparisons (Figures 5a, 5b, and 5c). This suggests that, for the large majority of management species, Pilot and MRFSS annual catch estimates (with all modes and waves combined) were not statistically different from one another. For 21 out of the 30 comparisons (i.e. estimates for 15 species each compared for landings and for releases) at least one survey estimate fell within the confidence interval of the other survey's estimate.

Figure 4a. 2010 weighted estimates of landings by survey and 95% confidence intervals.

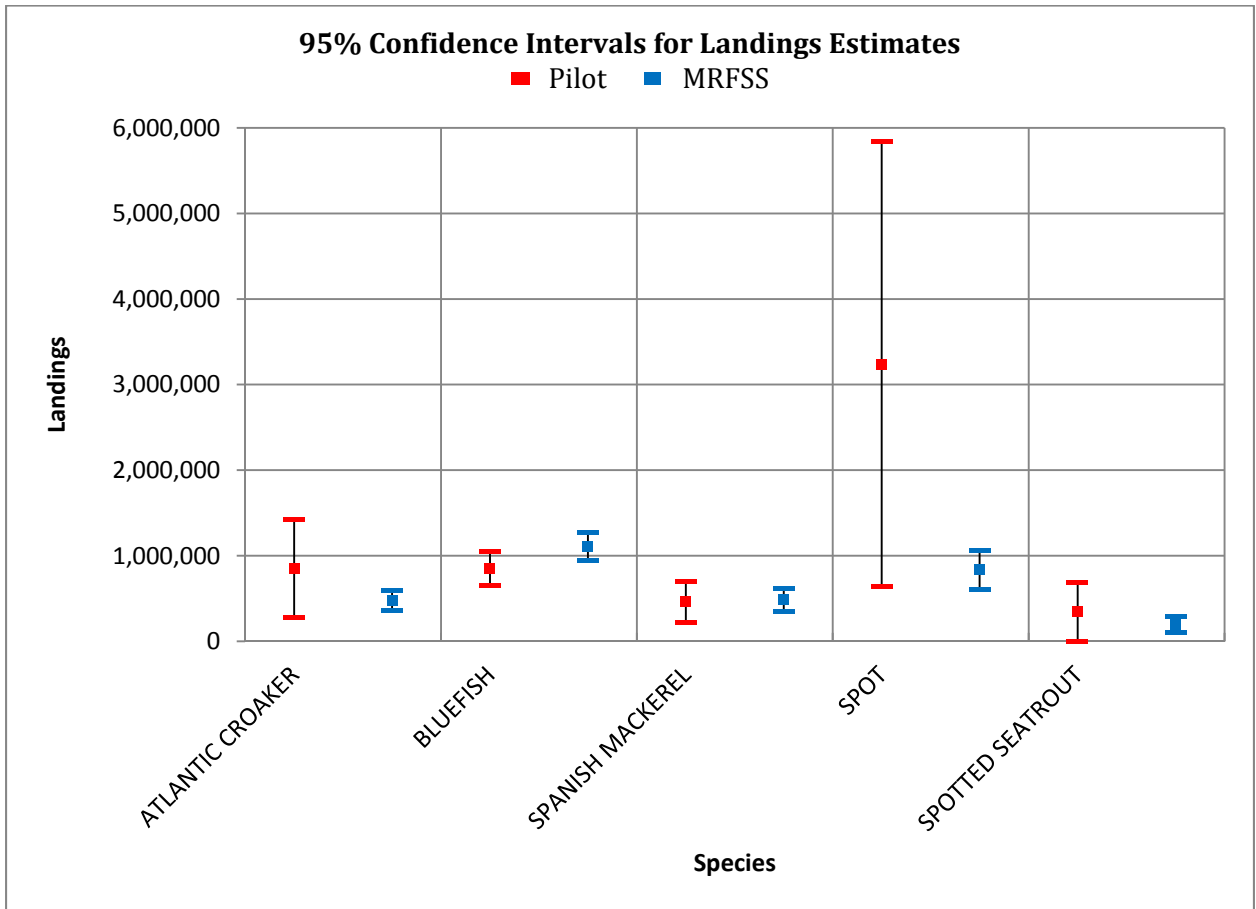

Figure 4b. 2010 weighted estimates of landings by survey and 95% confidence intervals.

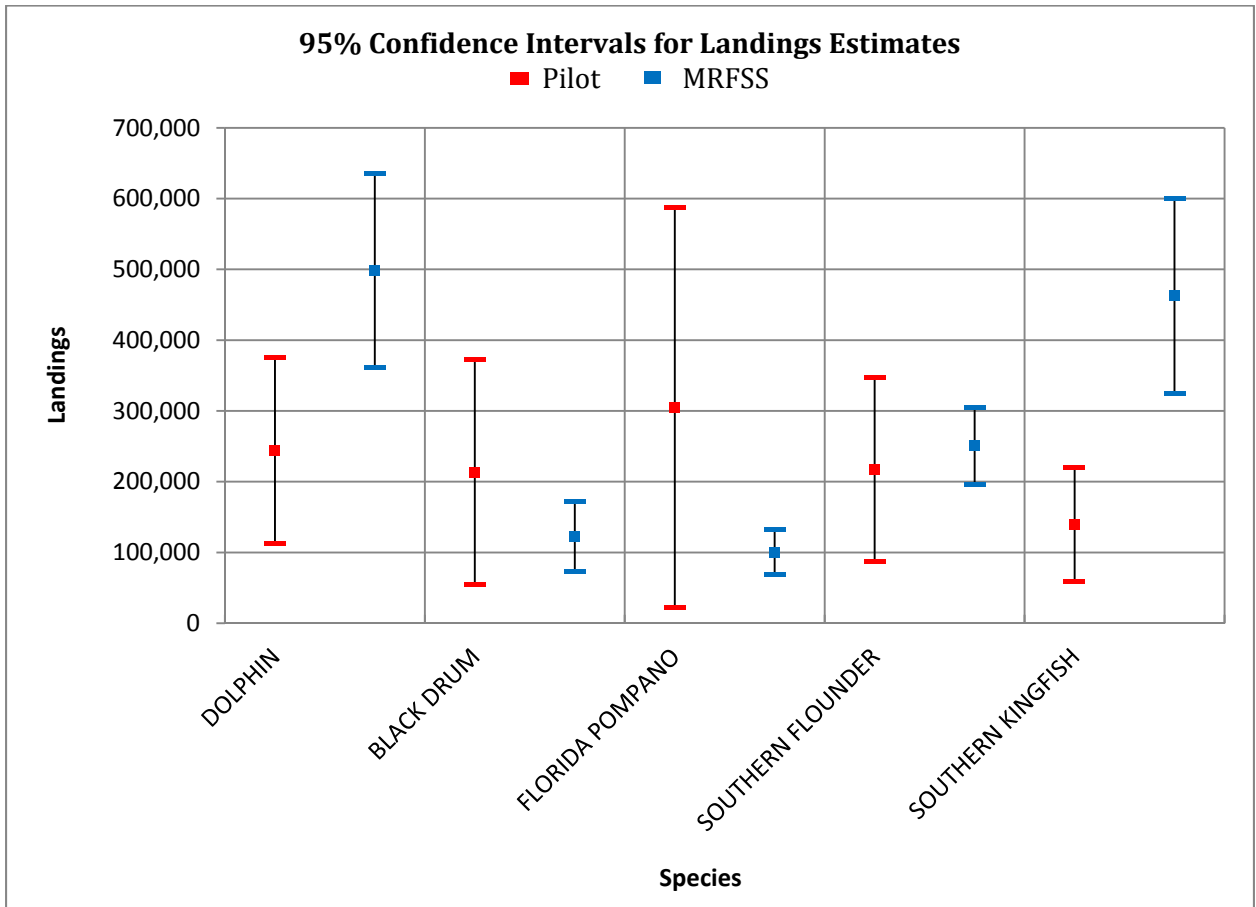

Figure 4c. 2010 weighted estimates of landings by survey and 95% confidence intervals.

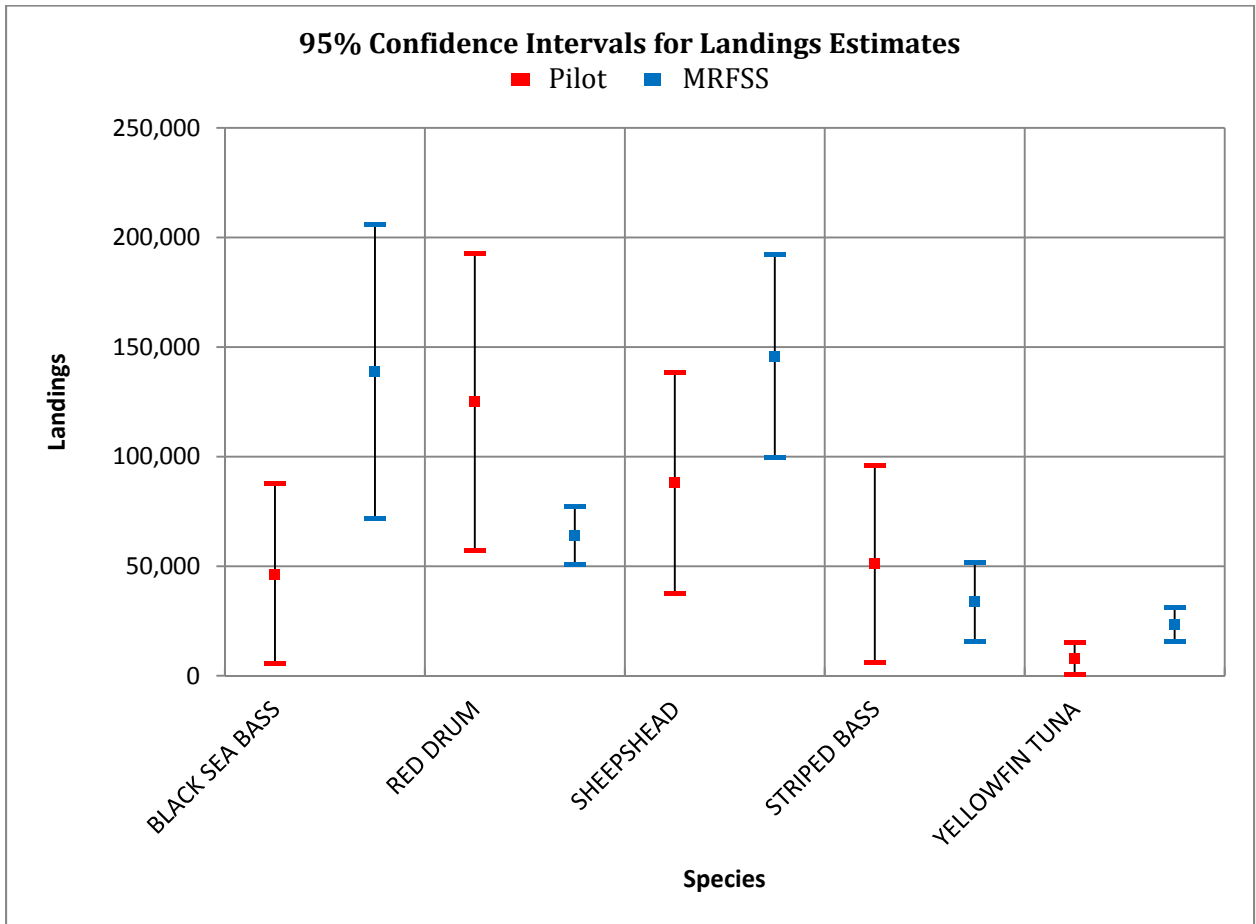

Figure 5a. 2010 weighted estimates of fish released alive by survey and 95% confidence intervals.

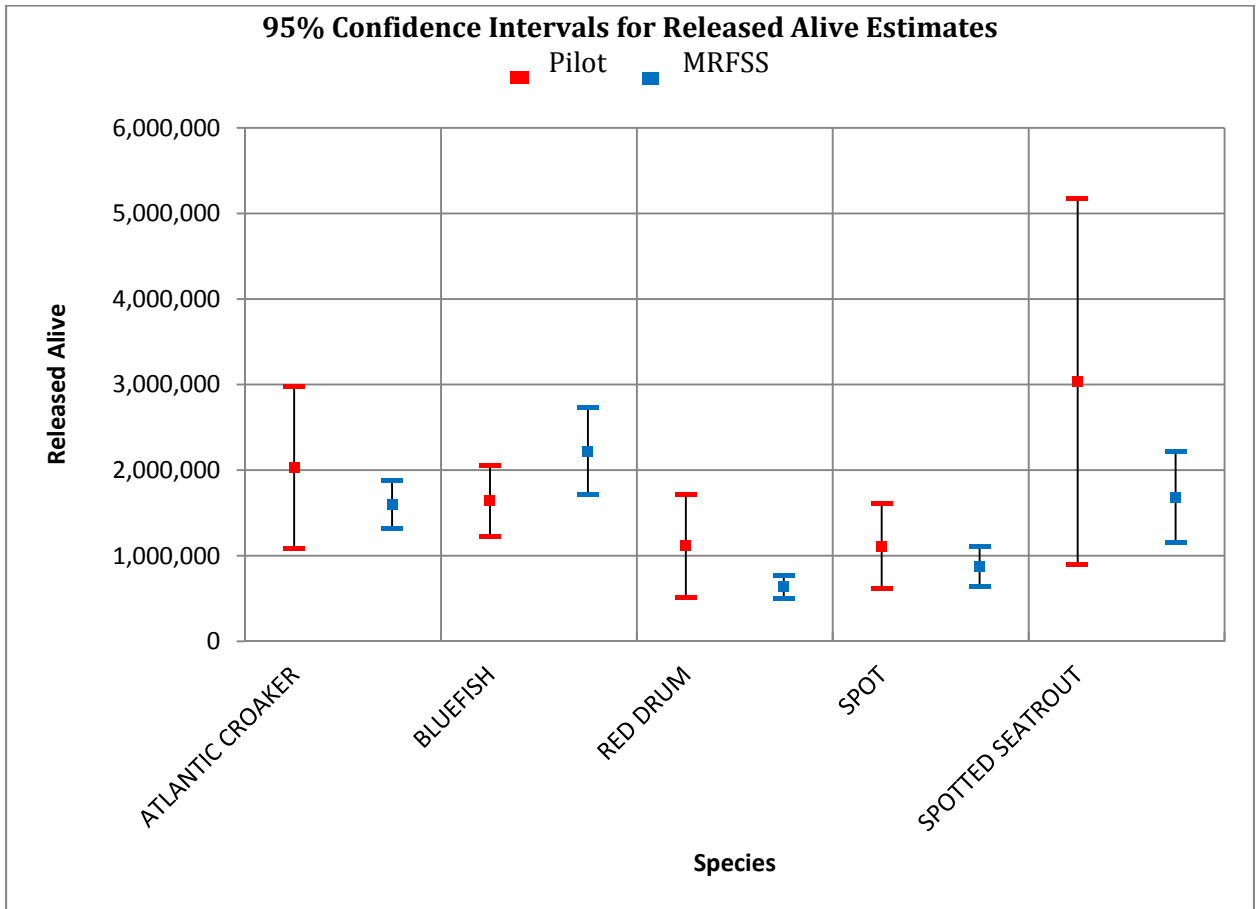

Figure 5b. 2010 weighted estimates of fish released alive by survey and 95% confidence intervals.

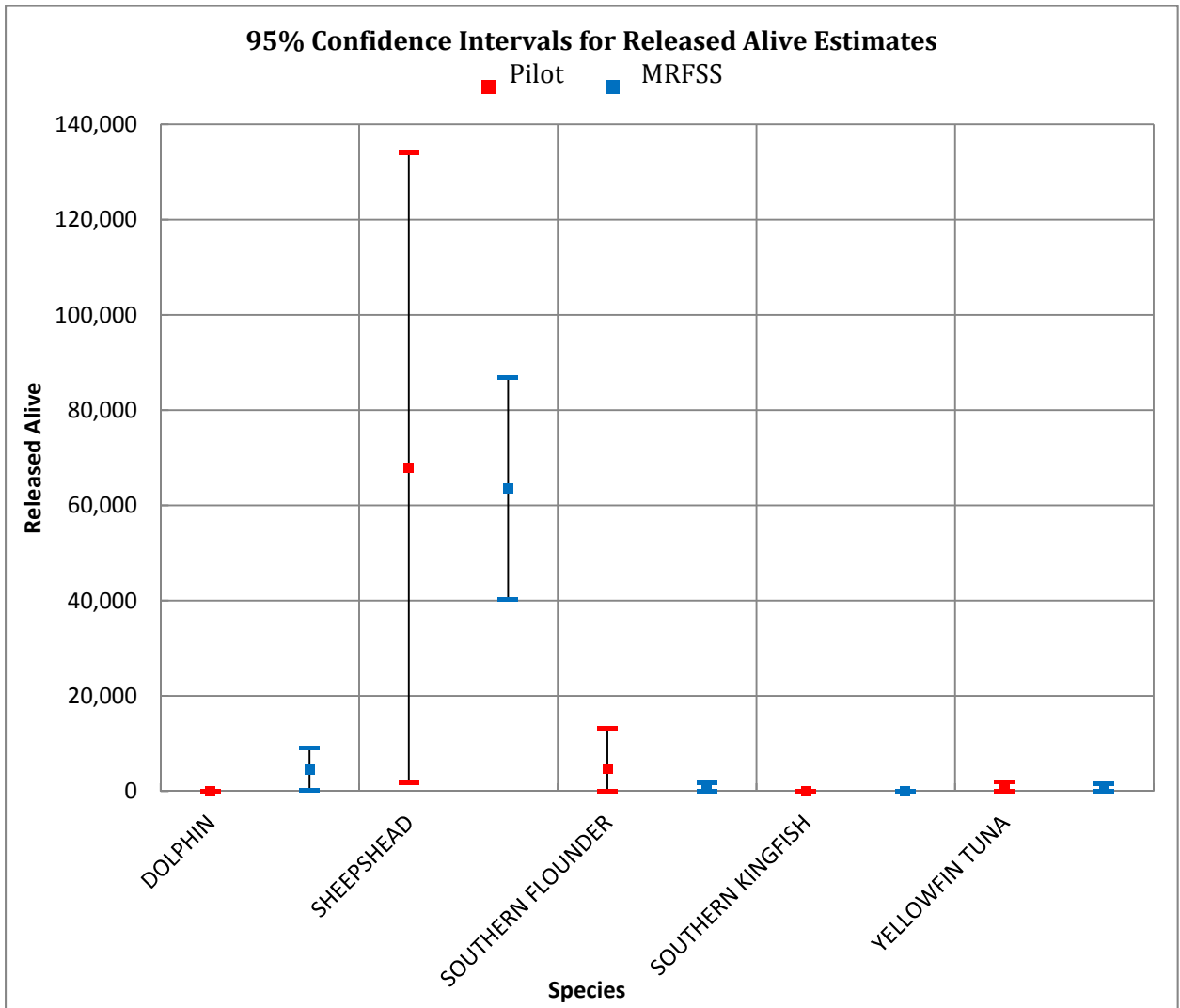
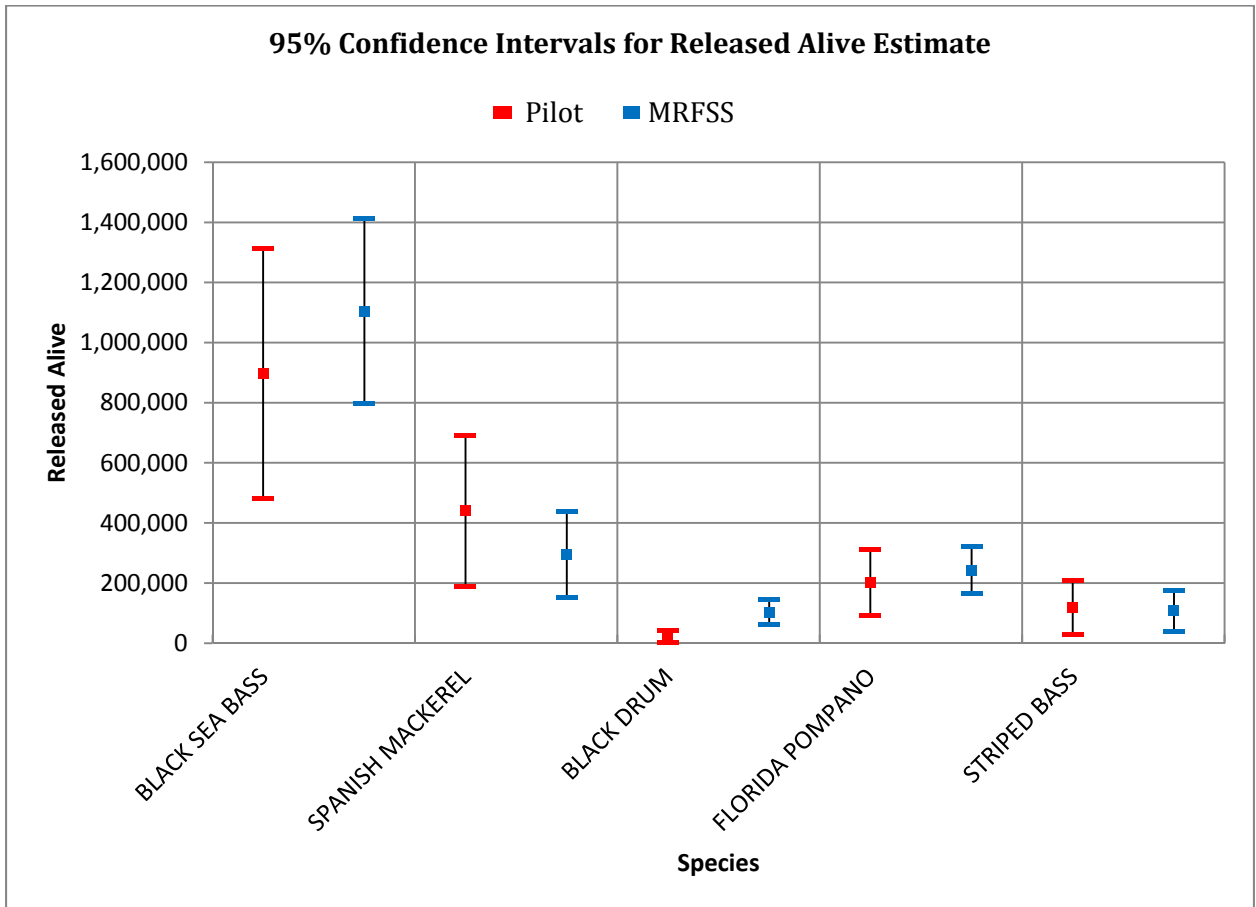



Figure 5c. 2010 weighted estimates of fish released alive by survey and 95% confidence intervals.



Comparisons of Pilot and MRFSS catch estimates at the mode/wave stratum level yielded similar results with 95<sup>th</sup> percentile confidence intervals overlapping in nearly 90% of all cases for both landings and released estimates (Figure 6). The boat modes (private and charter) more frequently had non-overlapping confidence intervals compared to the shore modes. Figures 7 and 8 show the difference in landings and released estimates, expressed as pilot minus MRFSS, for wave level comparisons (with all modes combined) with non-overlapping confidence intervals. The MRFSS estimate exceeded the Pilot estimate in about 95% of all cases with non-overlapping confidence intervals. In stratum level comparisons with overlapping confidence intervals the Pilot estimate often exceeded the MRFSS estimate. Stratum level differences in catch estimates are likely due to sample size effects (i.e., small sample sizes in many Pilot stratum) rather than an identified design bias.

**Figure 6. Frequency distribution summarizing degree of overlap between NC pilot and weighted MRFSS catch estimates (landing and released) and 95% confidence intervals across all mode/wave strata for 15 important management species (see Figures 4a, 4b, and 4c for species included).**

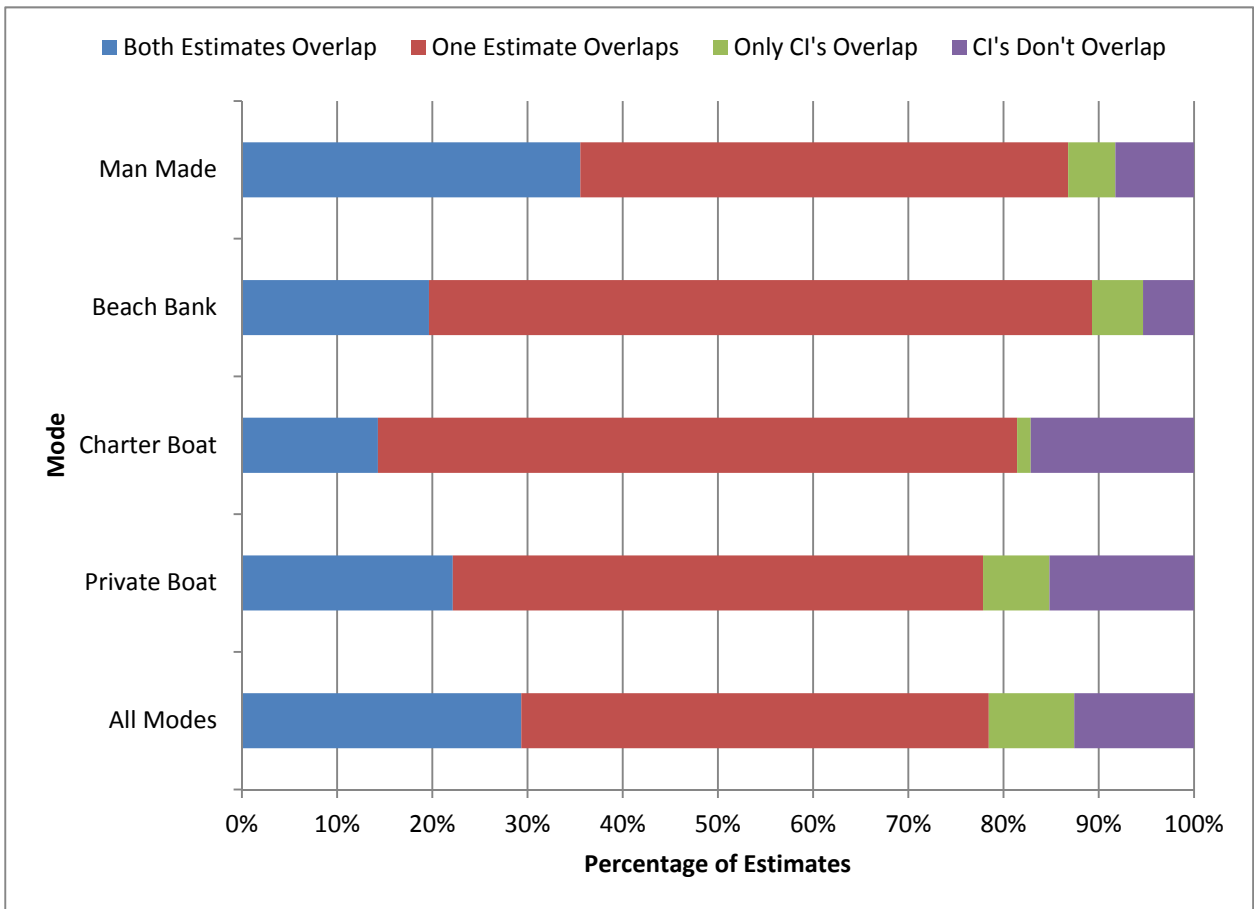
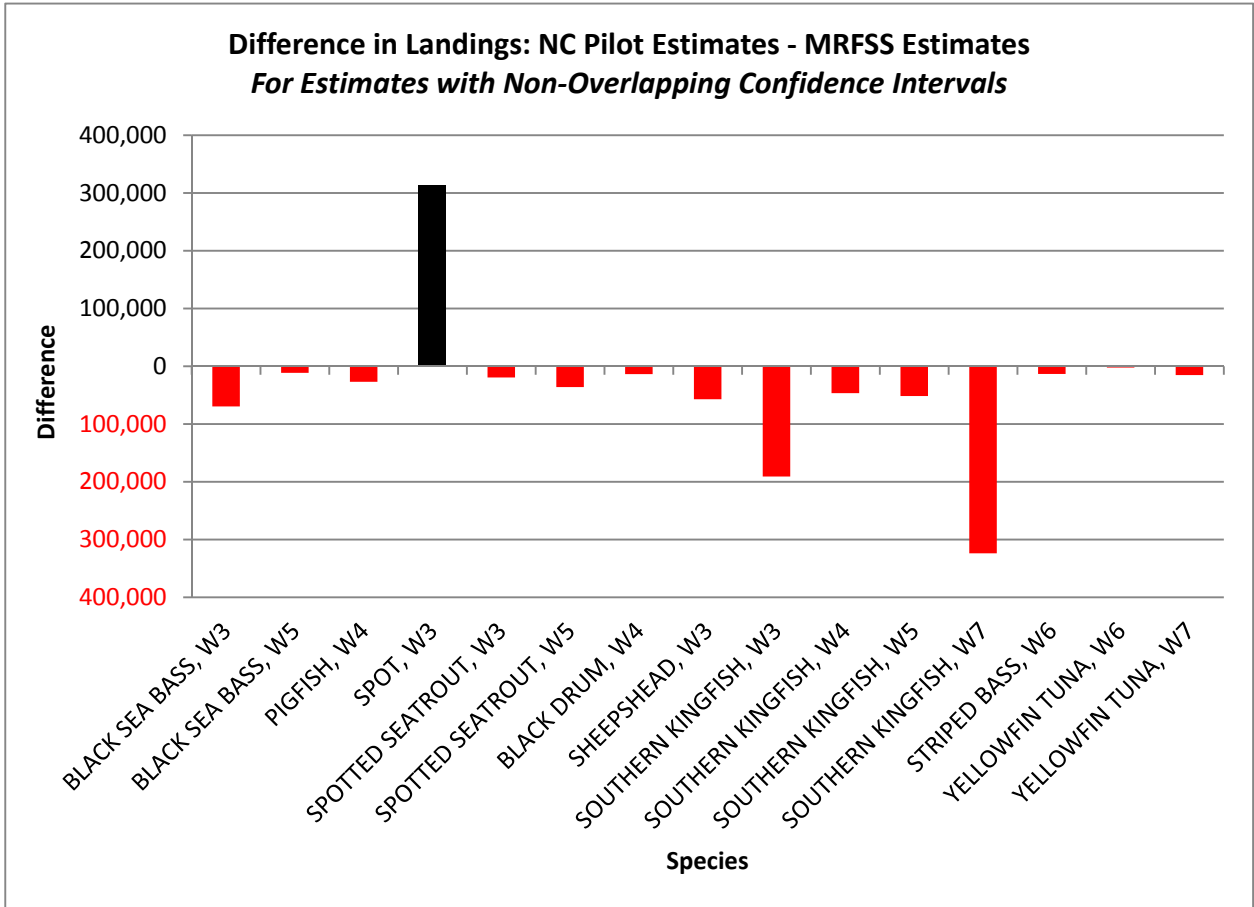
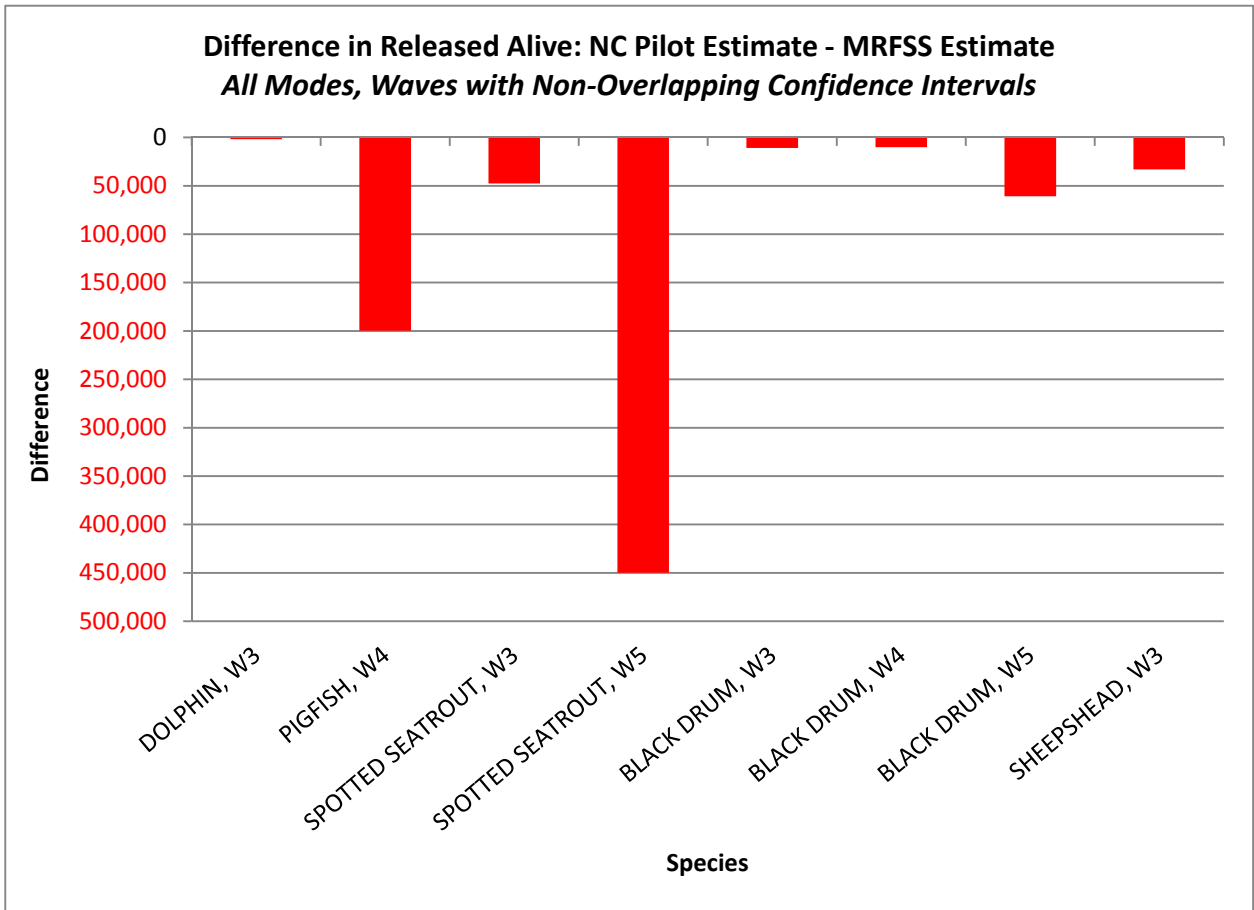

Figure 7. Difference in 2010 recreational landings estimates, expressed as NC Pilot minus (weighted) MRFSS, for wave level comparisons (with all modes combined) with non-overlapping confidence intervals.



**Figure 8. Difference in 2010 recreational landings estimates, expressed as NC Pilot minus (weighted) MRFSS, for wave level comparisons (with all modes combined) with non-overlapping confidence intervals.**



While the results suggest that annual level Pilot and MRFSS point estimates across all modes were reasonably close, there were a few particular mode/wave strata level comparisons where absolute differences were rather large, regardless of whether or not confidence intervals overlapped. In some of these cases, the MRFSS estimate was considerably greater than the Pilot and in others the Pilot estimate was considerably greater than the MRFSS. Strata level catch estimates with very large differences were examined more closely. Results of this analysis are shown in Appendix E.

### 4.3 Statistical Precision of Estimators

Proportional Standard Errors (PSEs) were consistently higher for pilot catch estimates than for MRFSS catch estimates due mainly to the smaller sample sizes used for the Pilot design and differences in sample distribution across modes and state subregions (Figures 9 and 10). An analysis was conducted to evaluate and compare the expected Pilot precision estimates with those derived using the MRFSS had sample sizes and allocations been more similar. Results suggest that the statistical precision of the Pilot design would be at least as good, and quite possibly much better than MRFSS with similar sample sizes and distributions (Tables 8 and 9).

**Figure 9. 2010 NC Pilot and (weighted) MRFSS landings Proportional Standard Errors (PSEs) with all waves and modes combined for 15 important management species.**

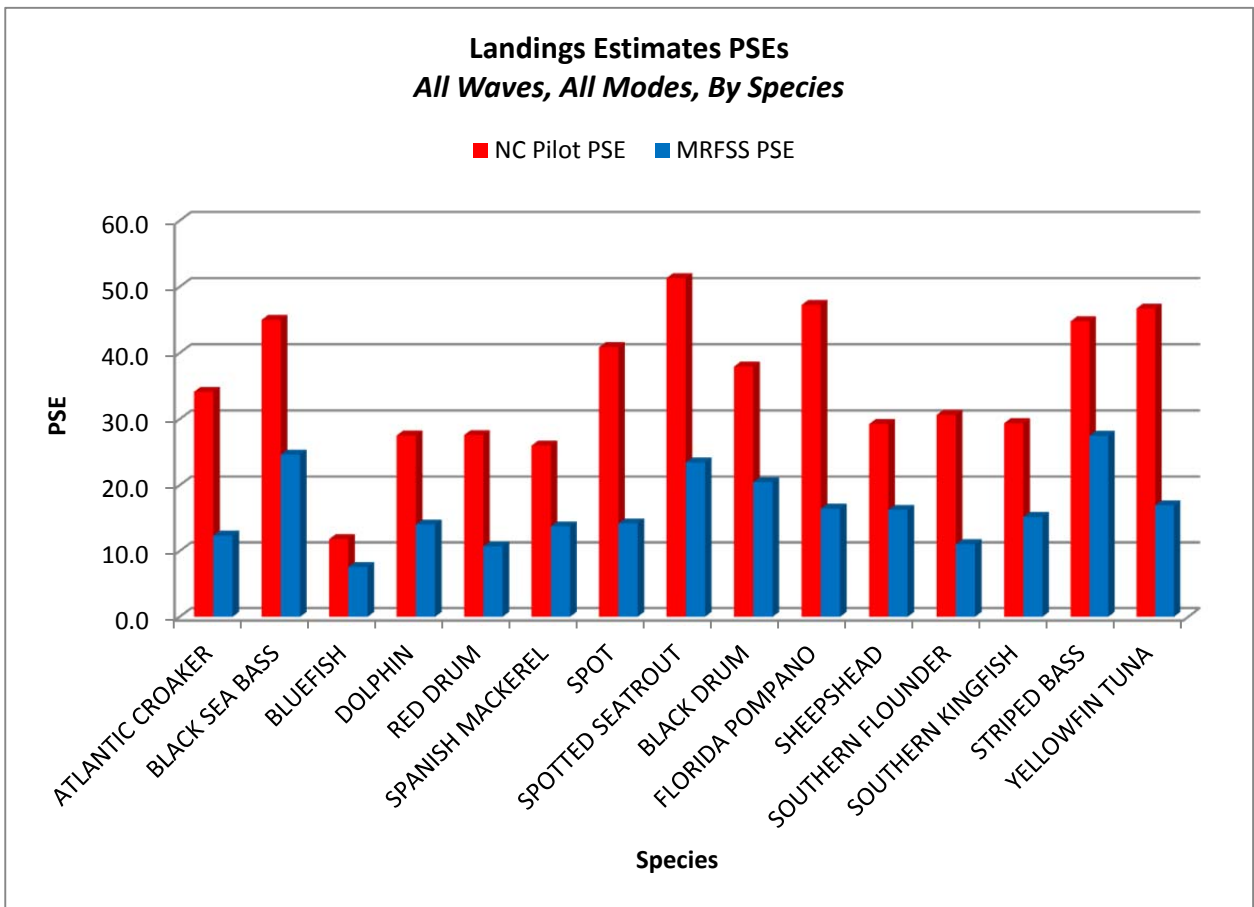

Figure 10. 2010 NC Pilot and (weighted) MRFSS fish released alive Proportional Standard Errors (PSEs) with all waves and modes combined for 15 important management species.

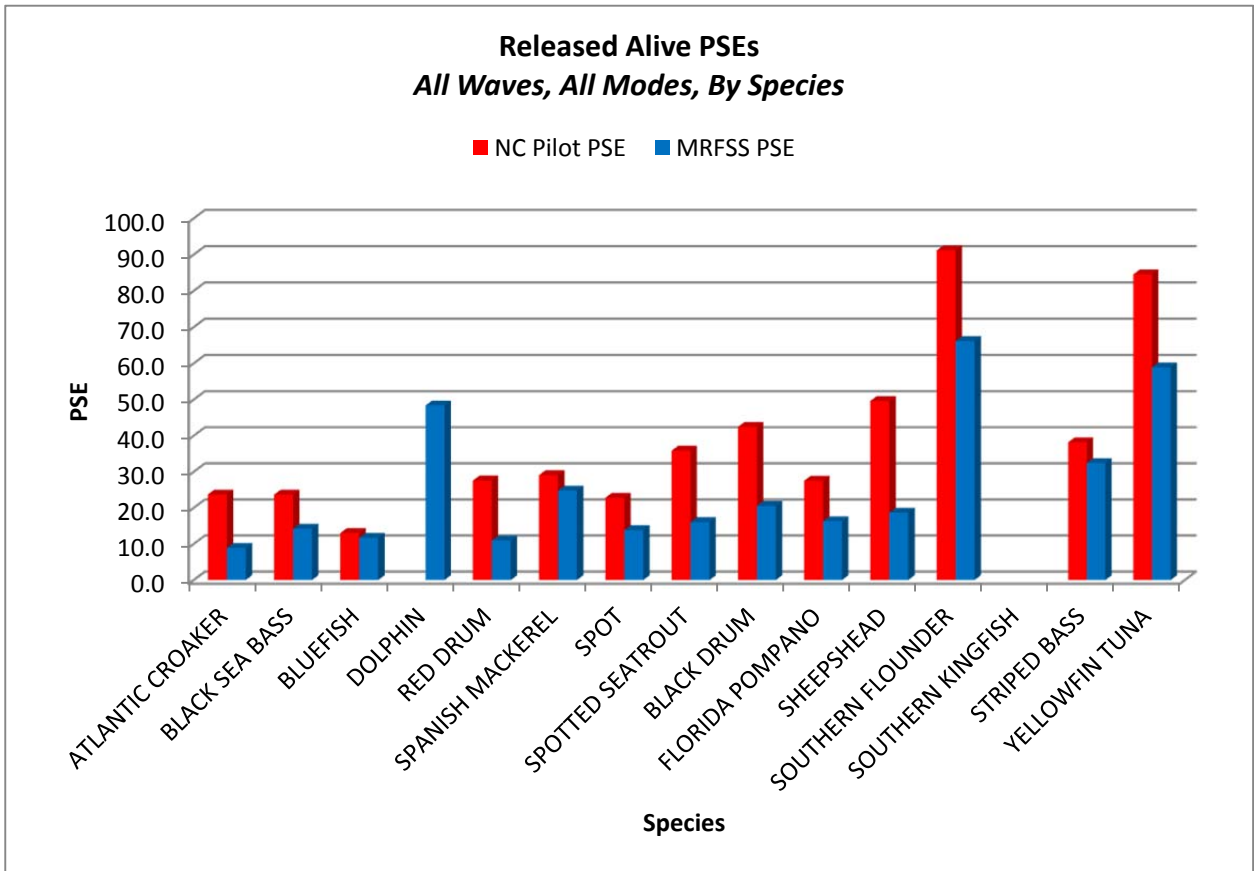

Table 8 compares variances of the total catch rate estimator for a “hypothetical Pilot” sample design with estimated variances based on the MRFSS design sample data using the ratio approach described above in Section 3.2.3. Ratios for two different hypothetical Pilot scenarios are shown: 1) same sample size and distribution of sample among fishing modes and geographic strata as was obtained using the MRFSS design, and 2) same sample size as MRFSS but an “optimized” distribution of sample to minimize variances. Table 9 shows similar ratios as Table 8 except that only “primary” site data are used for MRFSS variances (i.e., alternate sites excluded from the analysis). The relative efficiencies for the two types of sample allocations favor the Pilot design over the MRFSS design. The relative efficiencies are given for each of the four modes and overall. The estimated relative efficiencies range from close to 1 for MM mode without optimal reallocation to over 4 for several modes after reallocation. Hence, it

would appear that once the two designs are put on a comparable footing in terms of sample size, time-of-day survey scope, and allocation of sample among fishing mode and geographic strata, the new design is at least as efficient as the MRFSS, and potentially much more efficient.

It should be noted that this comparison is based on estimation of stratum-specific variances which, in the case of the Pilot, are based on small sample sizes. Hence, the estimated relative efficiencies are themselves rather variable and should be interpreted cautiously. In addition, these ratios compare Pilot and MRFSS variances for total catch with all species combined and may not necessarily reflect difference in variances one would expect to find for any particular species of interest.

**Table 8. Relative efficiency of hypothetical pilot to MRFSS with all sites (primary and alternate) under two allocations: same allocation as MRFSS with all sites, and optimum allocation. Values greater than one favor the hypothetical pilot design.**

Mode	MRFSS All Sites / Hypothetical Pilot: Allocation as in MRFSS All Sites	MRFSS All Sites / Hypothetical Pilot: Optimal Allocation
BB	2.6315	5.9020
CH	2.0578	5.0334
MM	1.0192	2.9251
PR	1.4429	2.3138
All Modes	1.5610	3.0171

**Table 9: Relative efficiency of hypothetical pilot to MRFSS with primary sites only under two allocations: same allocation as MRFSS with all sites, and optimal allocation. Values greater than one favor the hypothetical pilot design.**

Mode	MRFSS Primary Sites Only / Hypothetical Pilot: Allocation as in MRFSS All Sites	MRFSS Primary Sites Only / Hypothetical Pilot: Optimum Allocation
BB	1.8251	4.7210
CH	2.2437	4.7906
MM	1.0308	2.5610
PR	3.2384	4.8758
All Modes	2.5305	4.5415

## 5. Discussion and Recommendations

This section of the report is divided into the following subsections:

1. Discussion of the differences between the MRFSS sampling design and the new Pilot sampling design as revealed in the Pilot Study results.
2. Specific recommendations for immediate implementation.
3. Recommendations for further study.

### 5.1 Discussion of Differences

***Coverage and stratification of the spatiotemporal frame:*** The stratification of days into four six-hour time blocks in the Pilot design provides more representative coverage of fishing times, and, in particular, ensures a better representation in the sample of nighttime and off-peak daytime fishing trips than the MRFSS design provides. This stratification assured that angler trips ending at night, early morning or during off-peak daytime hours have a non-zero probability of being included in the sample. This eliminates possible bias in catch rate estimators that would occur if nighttime, early morning or off-peak period fishing trips differ in mean catch rates from peak period fishing trips, which are the main target of the MRFSS. The Pilot succeeded in obtaining angler intercepts in all time intervals for each mode and wave for which non-zero pressure was expected.

Furthermore, the six-hour duration for each time block stratum provided a consistent time frame for sampling that is lacking in the MRFSS design. Six-hour intervals worked well because they allowed up to two hours for samplers to travel to and from the assigned set of sites, as well as some additional time for editing of forms within an eight-hour standard work day. It was not necessary to require interviewers to regularly work overtime (more than an eight-hour day). The choice of time intervals also worked well for North Carolina. Activity peaks in the Pilot data tended to occur near the middle of the most active daytime six-hour time blocks rather than near the boundaries between them. The use of two samplers for nighttime assignments was deemed to be good idea for safety reasons, and night sampling was not problematic; no safety related issues were reported during this study.



The MRFSS design does not stratify fishing sites by subregion within a state. The stratification of sites into three geographic state subregions for the Pilot allowed for more representative coverage of different management areas and also made it easier to manage staffing of the interviewing assignments. The area north of Cape Hatteras is characterized by an assemblage of fish stocks that differs somewhat from the area south of Hatteras. In particular, two different stocks of black sea bass are identified to be separated by the Hatteras boundary. The northern area was established as a single sampling stratum for this study. The area south of Hatteras was split into two geographic strata of relatively equal stretches of coastline that could be easily covered by a staff of samplers without requiring large travel distances from a home office. There can be both statistical and management advantages to geographic stratification of sites/clusters by subregion within a state, particularly for a state like North Carolina that has both a considerable amount of coastline and regional variability in the stock composition of recreational catch. Overall precision may improve as a result of stratification if catch rates are more similar within state subregions than across state subregions. Stratification within a state can be done by dividing the site register using county boundaries (as was done for the Pilot) or well-defined geographic or natural boundaries (e.g. enclosed bay versus ocean).

***Change in definition of the primary sampling unit:*** Formalization of a probability-based approach for the selection of all site assignments allows for more accurate determination of correct PSUs which facilitates the calculation of sampling weights to be used in the estimation stage. MRFSS procedures allowed samplers to leave the assigned site (PSU in the MFRSS) and visit up to two alternate sites on a given assignment. Because the Pilot design eliminated the on-site decision-making by samplers regarding the selection and sampling of alternate sites, it was now possible to calculate the correct PSU sampling weights to be included in the estimation process.

The clustering of medium and low activity sites to produce 3-site and 2-site PSUs that could be combined with high-activity 1-site PSUs maintained the ability to specify their inclusion probabilities through a formal probability sampling method, while reducing the likelihood of assignments without interviews. The sampling of predefined sites and site clusters also eliminated potential for bias in the MRFSS design that could result from samplers making unpredictable choices of alternate sites.

The Pilot design effectively eliminated sampler discretion to choose both the start time and the duration of interviewing for a given assignment. Since the temporal dimension of each PSU in the Pilot design was a specified six-hour interval, the variability among

samplers in the time intervals chosen for data collection under the MRFSS design was eliminated. Under the MRFSS design, if different samplers consistently started collecting data at different times and consistently stayed on site for shorter or longer time periods than other samplers, then a spatial and temporal bias could have been introduced if catch rates varied in some consistent way with time of day and site. The potential for such a bias is eliminated with the new sampling design.

The new sampling approach allowed for more straightforward directions to be given to interviewers, thus eliminating a good deal of confusion or inconsistency regarding decisions about when and where to collect data. The pre-determined order of site visits and times for arrival and departure at each site eliminated any possible bias resulting from the variability among samplers in choices made regarding the order or duration of visits to individual sites selected in the PSU sampling approach. For the Pilot, samplers were instructed to stay a maximum of two hours on-site for all multi-site cluster assignments. For two-site clusters, this meant that samplers spent two hours at the first site, two hours at the second site, and then returned to the first site to finish out the six-hour time interval. These on-site procedural changes also assured that each site in the cluster had an opportunity to be sampled during different two-hour time blocks within a six-hour interval. If this decision were left to sampler discretion the same site may always be visited first (or last), which may introduce selection bias.

The use of ArcGIS for determining appropriate site clusters in this study is a novel approach that allows considerable flexibility in the way individual sites are sampled from wave to wave. This procedure worked very well to minimize driving time between sites, thereby maximizing the actual time period for data collection within the assigned time intervals. The accompanying computer algorithm assured that the number of sites in a PSU was determined by a cumulative measure of expected fishing pressure, resulting in less variability in the inclusion probabilities of individual PSUs. For this reason, the clustering of sites also effectively decreased the probability that any one intercepted angler trip would get an unusually high weight in the design-based estimation process.

The fixed time interval for interviewing assignments in the Pilot design also assured that angler fishing trips ending at different times within a given time block stratum would have relatively equal inclusion probabilities. MRFSS assignments had varying start times and durations that were set by decisions made by individual interviewers. The Pilot sampling design eliminates this variability and reduces the potential for bias that can result from differential sampling of time intervals when there are significant catch rate differences among angler fishing trips ending at different times.

***Sampling of interviewing locations in space and time:*** In general, the clustering of lower pressure sites into multi-site PSUs in the Pilot design increased their inclusion probabilities relative to the higher pressure sites. Higher activity sites still had higher inclusion probabilities than lower activity sites in the new sampling design, but there was generally less variability among sites in their probabilities and a greater chance that the sample was spread more evenly among sites of similar pressure. Under MRFSS, sites of equal pressure could wind up having different inclusion probabilities due to differences in their proximity to other sites. If a site was located close to several lower pressure sites rather than just one or two, then it was more likely to be selected as an alternate site.

The Pilot design's elimination of "alternate site" visits made at the discretion of samplers is a very important improvement. All sites and times for sampling are fixed in the formal draw of the PSUs, and the inclusion probabilities can be easily calculated for all site clusters, sites within those clusters, and angler fishing trips encountered within selected sites and time intervals. The MRFSS design specifies when alternate sites can be visited and how they should be selected. If all samplers followed the specified procedures in the same manner, it would theoretically be possible to determine the inclusion probabilities for sites as alternate sites in the MRFSS design. This would likely require complex modeling techniques that would employ contingent probabilities and distances to neighboring sites. However, it is not clear that all samplers have interpreted and executed the prescribed MRFSS procedures in the same way. Therefore, modeling of the inclusion probabilities for sites as "alternate sites" in the MRFSS design is not straightforward. Any biases that could possibly have been introduced by interviewer errors in the execution of alternate site protocols were essentially eliminated by the new design.

The Pilot design did not allow opportunistic sampling of newly discovered sites. New sites could be identified and added to the frame for sampling in the next month or wave, but they were not included in the same month or wave that they were identified. The MRFSS sampling design allowed "new" sites to be used by samplers as possible alternate sites. The value of adding new sites opportunistically to increase coverage would be outweighed by the difficulty of determining an appropriate weight for any data that was collected at the site.

The Pilot design's emphasis on completing a certain number of assignments, rather than a certain number of angler intercepts led to a considerable reduction in the level of unobserved PSUs in any given formal sample draw. This greatly reduced the possibility

of a nonresponse bias that could result from the inability to obtain observations from some of the selected PSUs (i.e., selected site-cluster-days). If observed and unobserved PSUs in the sample differ with respect to the mean catch rates of angler trips, then a high rate of non-observation in the primary sampling stage could lead to a significant bias in the catch rate estimators. Because the Pilot design places great emphasis on getting observations for all selected PSUs, it greatly reduced the potential for such non-sampling errors in the survey estimates.

In the Pilot Study, the goal of completing 100% of all the assignments that were drawn was nearly achieved. This is important for eliminating any possible bias that could result from preferentially completing some site-cluster assignments over others or from re-scheduling selected dates to match sampler requests or availability. The MRFSS design allows too much discretion in the completion of drawn site assignments and the scheduling of assignments. Consequently, many drawn assignments were either rescheduled or not completed. Changes in the pre-selected dates for some sample units and complete omissions of others could cause estimation biases. Rescheduling assignments can have unintended consequences on the sample design and could result in a distribution of assignments that is not representative of fishing activity or catch rates. Rescheduling is particularly problematic for the new estimation design because it complicates the assignment of sampling probabilities for weighting and estimation purposes. The Pilot procedure of not allowing assignments to be rescheduled removed sampler discretion in terms of which days they complete assignments and preserved the initial selection probabilities of the assignments. Whereas MRFSS assignments that are “weathered out” are rescheduled for another day, “weathered out” assignments in the Pilot were considered to be “completed” with the assumption of zero catch and effort within the cluster for that day.

The MRFSS emphasis on getting a certain target number of angler intercepts necessitates drawing many more assignments than can actually be completed with the existing staff. Therefore, many of the formally drawn assignments cannot be matched to an available interviewer. This opens the door to a possible preferential selection of some drawn PSUs over others, although the MRFSS has had strict procedures in place to try to avoid this possibility.

No PSU assignments were rescheduled in the Pilot sampling. If an assignment could not be completed on the assigned date, it was canceled. On the other hand, many of the MRFSS PSU assignments were rescheduled in accordance with specified procedures. The rescheduling could inadvertently lead to an uneven, non-random sampling of days.

This could result in either under- or over-sampling of a short-term change in catch rates for any given species, especially those known to be more or less available during brief pulse events.

The Pilot sampling resulted in a higher mean number of sites visited per PSU assignment than the MRFSS sampling, and the Pilot sampling also included more unique sites at a given level of PSU sampling. The Pilot sampling of PSUs also provided a better spread of sampling across time intervals. Although this was partly due to the temporal stratification of sampling, a comparison of the distribution of PSU sampling across one-hour intervals between 2PM and 8PM, the highest activity time block in the Pilot, showed broader coverage with the Pilot than with the MRFSS sampling design.

***Sampling of angler fishing trips:*** The Pilot design effectively spread the sampling of angler trips to appropriately represent a larger temporal slice of fishing. Under the new design, samplers did not have to worry about reaching their limit too quickly. Unlike the MRFSS, the Pilot did not set an upper limit on the number of interviews allowed per assignment, instead using fixed interview time intervals. Removing the intercept limit significantly reduced any potential bias associated with sampler discretion in selection of boats (for PR and CH mode) and anglers. Under the MRFSS, samplers have been instructed to randomly select boats for sampling, and to randomly select anglers within a group, if time did not allow for interviewing all anglers. The Pilot sampler training was more straight-forward as samplers were instructed to attempt to intercept all eligible anglers from all boats rather than attempt to sub-sample them.

Obtaining accurate counts of completed angler trips that were missed (i.e. not intercepted) was critical to this project. These counts are incorporated into the total fishing effort for individual sites, which, under the new MRIP estimation methodology, are used to appropriately weight samples. Although MRFSS samplers have always tallied “missed eligibles” on the Assignment Summary Form, until recently this information was not used in estimation. As a result, significantly less attention had been paid to sampler procedures for counting angler trips in the past.

The greater emphasis in the Pilot to obtain accurate counts of all completed angler fishing trips while on site was very important to assure greater accuracy in the calculation of the secondary stage sampling fractions that are needed to properly weight any obtained interviews in the estimation process. The categorization of possible missed angler trips as either “confirmed” or “unconfirmed” provided a means of evaluating the relative reliability of the observed counts. In general, a very high proportion of the counted missed trips were confirmed to be recreational angler trips in

the specific fishing mode of the interviewing assignment. Unconfirmed counts were more commonly recorded at high activity sites, suggesting that it is harder to get accurate counts at such sites.

Although two samplers were assigned to high activity sites in the first few waves of sampling, this was not deemed necessary in later waves. The idea was that one sampler would conduct interviews while the other was obtaining counts, and that they might alternate between counting and conducting interviews during the assignment. However, individual samplers found that they were able to get relatively accurate counts on their own even at the high activity sites. A comparison of the counts obtained in the Pilot and MRFSS sampling designs for sites in the highest pressure categories showed that the Pilot counts tended to be lower.

In the Pilot sampling design, the intercepted angler trips represented a much larger proportion of the total count of completed angler trips in the sampled time interval (6 hours rather than 24 hours). This meant that there was much less need to expand observed counts to estimate the total count for a sampled time period. In the MRFSS, the actual sampled time interval is a 24-hour day, but the observed counts and interviews were obtained in a much shorter time frame that could range anywhere from 2 to 8 hours. Because the observed counts in the MRFSS sampling design had to be expanded through an MRIP modeling procedure to estimate total counts for 24 hours, there was much more room for error in estimating those total counts. In the Pilot, only a minor expansion of observed counts was required to get an accurate count for the shorter time interval of 6 hours. The Pilot design sampling succeeded in getting observations from a higher percentage of the angler trips occurring within sampled PSUs. By staying on site longer, samplers executing Pilot design assignments were able to intercept a higher proportion of the trips ending during the temporal frame of the PSU. In addition, they were able to get a more representative sample because the intercepts were better distributed across the PSU time frame. MRFSS design sampling often resulted in interviewing assignments that lasted less than 6 hours, and some assignments lasted as little as 2 hours. This result is due to two factors: (1) MRFSS samplers were able to target the most active time of day at the assigned site and (2) MRFSS samplers were held to a cap of no more than 30 angler trip interviews per site within a PSU.

***Comparing estimates of catch rates:*** As a result of implementing a more rigid probability sampling approach in the Pilot Study, it was possible to use available data to directly calculate representative weighting of the angler trips that were included in the

survey sample without relying heavily on modeling. The inclusion probabilities for all intercepted angler trips were calculated with a design-based approach. We were able to easily calculate the sampling probabilities needed to weight the data in the estimation process, and those probabilities were less prone to possible errors than probabilities estimated through MRIP modeling procedures for the MRFSS sampling design.

***Comparing estimates of fishing effort ratios:*** The estimates of the proportion of fishing trips made by marine recreational anglers who could be contacted by the Coastal Household Telephone Survey of angler fishing effort were mostly similar in the two intercept surveys compared in this study. The inverse of this estimated proportion was used to adjust CHTS effort estimates to account for fishing trips made by anglers who could not be covered by CHTS sampling. Although there was some evidence that use of the Pilot sampling design resulted in an increase in this estimated proportion for the beach/bank shore mode, this study suggests that it is unlikely that the new sampling design will have significant impacts on the overall estimated APAIS effort adjustments.

***Comparing estimates of total catch:*** Differences in estimates of total catch by species were largely driven by differences in the estimates of mean catch per angler trip. For the large majority of management species, Pilot and MRFSS annual catch estimates (with all modes and fishing areas combined) were similar to one another. Pilot and MRFSS catch estimate confidence intervals overlapped for 13 out of 15 landings estimates comparisons and similarly for 13 out of 15 released estimates comparisons. More pronounced differences were noticed for some species as you drill down to the mode/wave/area level of estimation. In general, we expect that catch estimates based on the new Pilot design will be similar to those produced from the MRFSS design for most species. Differences observed in this study would likely have been greatly reduced if the Pilot design sampling had been conducted at the same level as the MRFSS design sampling.

For some species that are common targets for anglers ending their fishing trips during nighttime or off-peak daytime intervals, we would expect that the Pilot design estimates would be higher than the MRFSS design estimates. This may also be true for species associated with fishing tournaments because selected sites with fishing tournaments in progress (tournament weigh station sites) were not excluded under the Pilot design as they have been under the MRFSS design.

In this study, there was a suggestion that the Pilot design sampling yielded higher catch rate estimates for common night fishing targets like striped bass and red drum. On the

other hand, Pilot design catch rate estimates for many of the other species tended to be somewhat lower. Although these differences were not statistically significant, their directions match what you should expect to see with the addition of nighttime and off-peak daytime sampling.

**Sample size, sample yield, and precision:** In this study, the estimates generated from the MRFSS sampling design were more precise than the estimates generated from the Pilot design largely because more samplers were available to cover a greater number of sampling assignments in the MRFSS design particularly during the most active two-month periods (Waves 3-5). The number of assignments completed was consequently greater for the MRFSS sampling in those sampling waves. If the number of PSUs observed in the Pilot design had been increased to match the number of assignments completed in the MRFSS design, the analytical results in Tables 8 and 9 show that the estimated variances of the total catch estimates under the Pilot design would have been no greater, and possibly much lower, than those obtained under the MRFSS sampling design.

The Pilot design assignments observed significantly lower mean numbers of angler trips than the MRFSS design assignments across all four fishing mode strata. Although Pilot design assignments also observed significantly lower mean numbers of caught fish weighed and measured, the Pilot design and MRFSS design assignments had similar average numbers of fish observed per angler trip. This suggests that the main difference in numbers of fish observed between the two designs was due to a difference between designs in the probability of intercepting angler trips. A larger percentage of the Pilot assignments failed to get any angler trip interviews compared to the MRFSS assignments.

The differences in the proportion of assignments with angler intercepts and the mean number of intercepted trips per assignment were greatest in the sampling for the beach/bank shore mode. This was largely because the Pilot design did not allow intercepts of incomplete angler fishing trips as has been allowed under the MRFSS design for this fishing mode. Changing the rules to eliminate “incomplete interviews” was considered to be important for eliminating the potential “length of stay” bias that results because anglers who fish longer have a greater chance of being intercepted for such interviews than those who fish for a shorter period of time. In order to be interviewed under the Pilot design, the angler must have completed their day of fishing.

This lower productivity of the Pilot design as it was implemented for this feasibility study was driven by a number of factors that could be changed in future implementation



while still adhering to a strict probability sampling design. By design, MRFSS samplers visited sites much more consistently during their most active periods of fishing activity. The time-block stratification of the Pilot design sampling assured better coverage of fishing trips ending throughout a 24-hour fishing day, but the inclusion of numerous assignments directed at non-peak periods of fishing activity also resulted in both an increase in the percentage of empty assignments (i.e. no intercepts) and a decrease in the average number of angler intercepts per assignment.

Comparison of the mean number of intercepts per assignment between the MRFSS and Pilot designs for the most active 2PM-8PM interval showed a much closer match, but the MRFSS assignments still achieved slightly higher levels of non-empty assignments and mean numbers of intercepts. This can be explained at least in part by the fact that the MRFSS sampling assignments visited sites in the highest pressure categories more frequently than the 2PM-8PM Pilot design sampling assignments. This happened mostly because MRFSS samplers visited higher pressure sites more frequently than lower pressure sites as alternate sites.

## 5.2 Recommendations for Immediate Action

- 1. In general, the Project Team recommends use of the new access point survey sampling design tested in this pilot study for conducting future access point surveys on the Atlantic coast and in the Gulf of Mexico.** However, we also recommend some additional changes, not implemented during the Pilot, that we have outlined in this section. The recommendations below can and should be addressed prior to implementation of the new sampling design along the Atlantic coast and Gulf of Mexico. Most of these recommendations are focused on further improving the new sampling design to increase statistical precision without increasing costs.
- 2. The allocation of sampling among sampling strata should be changed as needed to maximize sampling efficiency and statistical precision.** Sampling could be allocated very differently among geographic strata, fishing mode strata, and time block strata than how it was allocated in this pilot study. Without introducing any bias, other sampling allocations will likely provide higher proportions of sampling assignments that obtain at least one interview and may also provide higher average numbers of interviews per positive assignment than were observed in the pilot study. The goal

should be to find the “optimal” allocation that will provide the highest level of statistical precision for the dollar spent.

Sampling could be allocated differently among geographic strata. In this study, the sampling for the Pilot design was distributed more evenly among the three North Carolina subregions than may be desired for future implementation. By contrast, more than 60% of the MRFSS assignments were conducted in the Northern subregion, where the majority of high pressure sites are located. The distribution of Pilot design sampling could be shifted to allocate a greater proportion of it to the Northern subregion.

Sampling could also be allocated differently among the different fishing mode strata. In this study, the Pilot design sampling was spread pretty evenly among the different modes, but the MRFSS design sampling was allocated to achieve proportionately higher levels of sampling in the private boat and charter boat modes. In general, sampling in the boat modes tends to be more productive than in the shore modes. In addition, more of the key management species are caught primarily in the boat modes. Therefore, efficiency may be improved by allocating a higher proportion of the total sampling to the boat modes when implementing the new design.

Sampling could be allocated differently among the different time blocks of the Pilot design. In this study, sampling was deliberately spread across the time blocks to test the feasibility of sampling at nighttime and off-peak daytime intervals. For future implementation, the proportions of sample allocated to the nighttime and off-peak daytime blocks should probably be reduced to achieve higher levels of productivity (efficiency). As long as some sampling is allocated to all non-peak time blocks, the Pilot design will be less susceptible to possible undercoverage bias than the MRFSS design.

- 3. The formal PPS sampling of sites and site clusters should be controlled to ensure all drawn assignments can be completed by existing staff.** Following the pilot study, the project team developed a “controlled selection” program for possible use in selecting PSU samples for future intercept surveys. This program is briefly described in Appendix F. It is important to clarify that the use of a controlled selection program does not imply that sampling levels would be dictated by staffing levels. Staffing levels for the access point surveys should always be set to match the sampling levels required to deliver desired levels of statistical precision on resulting

estimates of mean catch per trip. Once those staffing levels are established, a controlled selection program can be used to ensure the draw of a probability sample of PSUs that can be covered by the existing staff. If staffing constraints are taken into account, then the number of assignments drawn for any given day will not exceed the number of samplers available to work that day. Constraints on the number of assignments possible in a given day and on the possible stacking of assignments back-to-back should be built into the sample draw program such that it is possible to match all selected PSUs with an available sampler. The universe of PSU samples that can be covered by existing staff should be identified and randomly sorted prior to random selection of one of those samples. The expectation would be that all drawn site-day assignments would be completed, and none would go unobserved. This would essentially eliminate the possibility of an unobserved sample, or nonresponse, bias. With this approach the probabilities of selection and joint probabilities of selection needed for estimation purposes would also be relatively easy to calculate.

One particular constraint that should be added would be to prevent the draw of more than one assignment for the same cluster, day, and time interval, even if they are in different modes. This would be important to prevent having two samplers at the same location at the same time, which could create a perception of overall survey inefficiency. This was handled in the Pilot study by canceling some assignments to avoid such overlaps, but it would be handled better by adding a constraint to the draw program.

- 4. Provide clearer instructions to samplers about how to handle the catch of charter boat captains and crew.** The MRFSS Statement of Work contains the following language regarding interviewing for-hire captains and crew: “The captain and deckhands should not be interviewed, regardless of whether or not they caught any fish during the trip.... They are not considered "recreational anglers" even though they might have fished.” Based on anecdotal information, interpretation of this procedure has been inconsistent across states and individual samplers in the MRFSS. While captain and crew should not be interviewed and are not counted as “contributors” for grouped catches, it was less clear whether or not their catch should be added to the catch of paying passengers. Excluding these fish represents a gap in the landings data whereby catch by captain and crew are not accounted for in any survey. In the Pilot design, samplers were instructed to include any catch by the captain and crew that were mixed in with the observed catch (Type A catch)

recorded for a group of charter boat anglers, but they were also instructed to not count the captain and crew as contributors to the mixed group catch. This procedure should be consistently followed when recording catch at the level of the boat trip in the future implementation of the new design. For regulatory purposes, captains may count themselves and their mates as “anglers” even if they did not fish or catch fish so the boat can keep more fish if there is a per angler bag limit. However, for survey purposes, as long as these trips are consistently not counted as “recreational” in both the intercept and effort (phone) surveys, a bias should not be introduced by including fish caught by for-hire captains and crew in group catches.

- 5. Collect total catch data for any intercepted angler who just completed a multi-day fishing trip.** In the pilot study, sampling under both the MRFSS and Pilot designs collected catch data for only the last day of a multi-day angler fishing trip. Angler fishing trips that span more than a single day are often referred to as over-night trips or multi-days trips. While relatively rare compared to day trips, it is still important that data from such trips are recorded consistently by samplers in a manner that will not bias catch rates or other data analyses. While there are several ways a “trip” can be defined, the project team recognized that for purposes of catch estimation this definition should ideally be consistent between the intercept survey which produces catch per trip rates and the effort (phone) survey which produces estimates of numbers of trips. Under the current MRFSS “trip” is defined as fishing during part or all of one waking day (as opposed to a calendar day) in one mode. The Coastal Household Telephone Survey asks respondents to recall the number of days fished (not number of trips) in the past two months. Using trip profile information (i.e., mode(s) fished, specific dates, and return times) it is then possible to determine the number of "trips" for estimation purposes to match the intercept survey definition. MRFSS intercept samplers are instructed to only record catch for the most recent waking day fished. Although the two survey components are consistent, under the current MRFSS intercept procedure there is no way to verify whether the catch recorded was from only the most recent waking day. In practice, anglers returning from a multi-day trip may have trouble remembering which specific fish were caught on which particular days. In addition, the most recent waking day’s catch may not be reflective of the trip as a whole since a considerable amount of time is spent in travelling back from the fishing grounds on the last day and not actively fishing.

The NC pilot followed the same protocol as the MRFSS regarding treatment of multi-day trips. However, the project team recommends adding the following question to future Intercept forms to indicate how many fishing days the Type 3 catch represents:

\*26.b. Were these fish all caught today (that is, from the time you woke up to the time you ended your fishing trip) while fishing from \_\_\_\_\_ (insert mode)?

1  Yes      8  N/A

2  No

\*26.c. If No, how many waking days did you spend catching these fish?

No. of days      88  Not Applicable

This question only applies to the Type 3 (Available) portion of the catch and samplers were still instructed to obtain Type 2 (Unavailable) catch information only for the most recent waking day of fishing. Since overnight trips are possible from all modes (not just boat modes) and it is preferable to keep procedures as consistent as possible for the samplers, the team decided this additional question should be asked for all fishing modes. This additional question makes it possible to calculate an average catch per day to represent the catch for the intercepted angler’s day of fishing.

6. **To increase on-site productivity and reduce driving time, instruct samplers to stay up to 3 hours (rather than only two hours) at the first site when a two-site cluster is assigned.** This may be particularly advantageous in situations where driving time between two clustered sites is long. For the Pilot Study, the project team considered increasing the maximum time spent at each site for two-site clusters (e.g. 3 hours per site) but ultimately decided to keep the two-hour limit. This decision was based on the rationale that samplers would have an easier time remembering how long to stay if the duration per site was consistent across three-site and two-site assignments. The change to three hours for the first site would make more efficient use of the on-site sampler time for the purpose of data collection.

### 5.3 Recommendations for Future Consideration

In addition to the recommendations above for immediate implementation with the new design, the project team also identified several recommendations that require additional study and evaluation. These are not presented in any specific order of priority.

- 1. Consider using the average pressure of a site cluster rather than the total pressure to determine its selection probability for sampling.** When a sampler is conducting an interviewing assignment to visit a cluster of two to three sites, he/she only encounters the activity at one site at any given point in time. Therefore, it would probably be more reasonable to base the selection probability of any given site cluster on the average expected fishing pressure of the sites in the cluster. In the pilot study, the total pressure of the sites was used to determine the cluster's selection probability for sampling. Making this change would increase the probability of selection for stand-alone sites with expected pressures that exceed a certain set threshold and decrease the selection probabilities of multi-site clusters formed using the remaining sites that are below that threshold. This change could increase the proportion of assignments that obtain at least one interview and also increase the average numbers of fishing trips encountered per assignment. As long as each site with expected activity has a non-zero probability of being selected either by itself or as a member of a multi-site cluster, this change should not increase potential for bias.
- 2. Consider requiring samplers to obtain counts of all boat trips on which anglers have finished fishing for the day.** The current estimation procedure develops weights within each observed site-day or site-cluster-day that are based only on the sampled fraction of the total number of angler trips counted. Given that boat angler trips are actually clustered together within different boat trips, it may be better to obtain total boat trip counts and assign counted angler trips to specific boat trips. This would allow determination of appropriate sampling fractions at both the secondary (boat level) and tertiary (angler level) stages of the multi-stage sampling design. Each boat trip represents a cluster of angler trips that fished similar locations and time periods with similar fishing gears and methods. Because these angler trips are likely to be more similar to each other than to angler trips made on other fishing boats returning to the same site within the same sampled time period, the sample inclusion probability for each boat trip could be determined and taken into account in the estimation process. The Pilot study did not obtain counts of returning boats, but a method for obtaining boat trip counts could be developed and used in future implementation of improved access point surveys of private boat or

charter boat fishing. Similar to angler counts, boats counts could be divided into “confirmed” and “unconfirmed” depending on whether or not the sampler was able to screen someone on the boat regarding fishing activity.

- 3. Consider collecting catch data at the boat trip level rather than at the angler trip level for the boat modes of fishing.** This would eliminate a stage of sampling, thereby reducing both sampling error and the potential for sampler errors (i.e., non-sampling errors) in the selection of boat anglers for interviews. This change would also require the development of new on-site sampling protocols. Samplers would have to conduct interviews that would obtain data on the total catch of all anglers who fished on the boat trip, as well as the location, duration, and primary fishing target of the boat fishing trip. They would also have to obtain counts of the total number of anglers who fished on the boat, as well as total counts of their observed (Type A) and unobserved (Type B) catches. It may still be necessary to interview a random sample of the anglers who fished on the boat to collect data needed to determine their potential for being contacted by an off-site telephone or mail survey of fishing effort. However, mean angler catch rates could simply be calculated by taking the total catch for the boat trip and dividing by the total count of anglers who fished.
- 4. Consider including for-hire "guide boats" in the private/rental boat mode instead of the charter boat mode.** For-hire “guide boats” may have more in common with private boats than with charter boats. Guide boats tend to be smaller, more transient, use multiple access points and boat ramps, and have less predictable trip schedules compared to charter boats. They may also target species that are more likely to be targeted by private boats than by charters. As a result, guide boats may also be more likely to be intercepted at sites with private boat activity than at charter boat sites in many areas. Adding guide boats to the private boat stratum may address an undercoverage issue associated with these trips and may increase sampling efficiency by eliminating very low pressure sites guide boat sites.
- 5. Evaluate options for combining boat mode trips (private/rental, guide boats, and charter boats) into a single stratum.** Sites with boat mode fishing activity often include a combination of private boats and for-hire boats. Combining these modes into a single stratum could result in more efficient sampling and fewer assignments resulting in zero intercepts obtained. If needed for management purposes, separate

catch estimates could still be calculated for private boat and for-hire sectors by treating these as "domains" within the boat mode stratum.

- 6. Consider implementing more rigorous protocols to ensure random sampling of observed fish for weight and length measurements.** In the pilot study, samplers selected fish for measurements in the same manner under both the Pilot and MRFSS sampling designs. However, the project team discussed ways to improve the MRFSS sub-sampling fish procedures and developed a more rigorous random sampling protocol that would be feasible for field implementation. This new procedure is described in Appendix G. We recommend testing of this protocol.
- 7. Consider basing rules for clustering sites more strictly on how geographic strata are defined.** In the Pilot design, sites were only clustered together if they were within the same county. In the future it would be more appropriate to cluster sites across county boundaries if you are not stratifying the state by county. If one wants to stratify the state into geographic subregions, one just has to make sure the rules for clustering are set up so that only sites within the same geographic stratum can be clustered together.
- 8. Evaluate how best to use “confirmed” and “unconfirmed” counts of trips in calculating the secondary and tertiary stage sampling fractions used to weight the data.** If “unconfirmed” trips make up a small proportion of the counts, it may not be necessary to include them in the weighting of data. The number of “unconfirmed” trips could still be used to evaluate or adjust site pressures for a given time period. If this proportion is relatively large, future survey designs may want to consider an adjustment factor to account for the fact that some proportion of the “unconfirmed” trips will not actually be eligible for interviewing. It may also be interesting to compare the ratio of “confirmed” to “unconfirmed” trips across sites to determine if this ratio is relatively consistent across sites or there is a high degree of variability.
- 9. Consider modifying the rules for clustering sites to use a total fishing pressure threshold as a basis for determining the number of sites in a multi-site cluster.** In the Pilot design, sites below a certain pressure threshold were clustered to form three-site clusters whenever possible. Few two-site clusters were formed, because such clusters were only formed when there were not enough lower pressure sites within close proximity to allocate to three-site clusters. However, creating more



two-site clusters would reduce the amount of time spent driving between sites. If a selected two-site cluster exceeds an established total pressure threshold similar to the one established for stand-alone sites, then it should not be necessary to add a third site to the cluster.

**10. Evaluate the feasibility of sampling beach/bank shore mode fishing trips in all states using a strict access point survey design as tested in the pilot. In the Pilot study,** it was assumed that all angler fishing trips ending at each identified beach/bank site could be appropriately sampled by stationing a sampler at a single access point. This may not be possible in other states where access to beach/bank fishing may be more diffuse and well-defined access points would be harder to establish. In such cases, it may be better to sample beach/bank shore angler trips through a “roving creel” sampling design that allows the collection of data for “incomplete trips”. Consideration should be given to the potential disadvantages of introducing a “length of stay” bias through the use of a roving creel design. If the access point design is deemed to be appropriate, eliminating incomplete interviews will likely reduce the number of intercepts per shore mode assignment and the impact of this change will vary geographically. If the access point design is not deemed appropriate for sampling of beach/bank fishing trips, then it may be necessary to separately sample man-made shore trips and beach/bank shore trips as different strata (as was done in North Carolina).

**11. Evaluate the possible use of access point survey data to produce estimates of total fishing effort at sites included in the sampling frame.** The Project Team began to examine possible access point survey methods for effort estimation, but we recognized that further study is needed. Further study should be directed at determining whether or not on-site survey data on fishing effort could be used effectively in conjunction with off-site survey data to improve the accuracy of total fishing effort estimates. It may be very difficult to accurately identify and evaluate differences in estimates for overlap domains, because this would require some way for off-site interviews to accurately obtain information on the actual fishing sites to which anglers return from fishing. Such information could potentially be very hard to obtain and would require a substantial increase in the complexity of a telephone or mail interview. The advantage gained by doing this would have to be weighed against the possible disadvantages of increasing non-response rates.

**12. Consider splitting sites rated to have very high fishing pressure to create more total sites in the highest pressure category.** This could provide more high-pressure alternatives to assign when the number of available days for sampling is limited, such as for weekend assignments. This would provide more PSUs that are likely to be highly productive when selected. As it is now, some of the highest pressure sites get selected for all available weekend days in a month. Any increase in the selection probabilities for such sites would not increase the numbers of assignments allocated to them if all available dates are already getting saturated. However, the splitting of some of the highest pressure sites would create more high-pressure alternatives to possibly assign on the limited number of available days. Splitting these “super sites” could also have the added benefit of improving angler count data since it is more difficult to obtain accurate counts of missed eligible trips at very high pressure sites. However, the project team did note that high pressure sites should only be split if the configuration of the site allowed for a clear demarcation of angler trips returning to one site or the other and the site boundaries could easily be explained to samplers.

**13. Consider conducting separate “frame maintenance assignments” that would survey sites and provide site register updates without attempting to collect any interviews.** Such assignments could be focused on improving the quality of the site register and the accuracy of site pressure ratings. The more accurate the pressure ratings, the more efficient the sampling can become. Inaccurate site pressure ratings would not cause any bias, as long as the inclusion probability of each site is easily known for weighting purposes. However, the proportion of assignments that obtain at least one interview should increase as the accuracy of the fishing pressures used in the PPS selection of sites and site clusters is improved. Frame maintenance assignments can also be used to identify new sites to add to the site register.

**14. Consider alternative ways to define size measures and weights for sites and site clusters in the sampling frame.** The Pilot sampling design adapted the traditional MRFSS pressure categories for use as size measures for the PSUs. The categories were translated to angler counts during each six-hour period for a site and mode. Size measures were summed over sites in a cluster when a cluster of two or three sites was used as the primary sampling unit. Depending on the clarified objectives, size measures might be based on projected catch rather than total anglers. It also appears that it may be beneficial to expand the range of fishing pressure category size measures at the high end to get more representation of the

heavily fished PSUs in the sampling. This possibility should be evaluated prior to implementation of the new design in other states. It may also make better sense to simplify the measurement of expected fishing pressures across fewer size categories. Consideration should be given to the potential advantages and disadvantages of lumping (into fewer categories) versus splitting (into more categories), and decisions should be based on how reliably site pressures can be estimated and assigned to an appropriate category. If site pressures are likely to be extremely variable and hard to estimate accurately, it may be more appropriate to designate expected site pressure more simply as “high”, “medium”, or “low”. On the other hand, if site pressures are not very variable and they are easily assessed, then it may be beneficial to create more categories to more precisely match the weighting of sites and site clusters in the assignment draws with their actual activity levels.

Pilot design sampling could also be changed in other ways to increase efficiency. More weight could be given to PSUs with higher pressure estimates in the PPS sampling. As long as lower pressure PSUs have some non-zero probability of being selected, an increase in the inclusion probabilities for higher pressure PSUs would not introduce any bias. However, too much of a shift of sampling toward the higher pressure sites would increase the variability among sites in their inclusion probabilities, thereby increasing the variability of sampling weights applied in the estimation process to the intercepts obtained. In other words, if sampling is shifted too much toward high pressure sites, the chances will be much greater that some small number of angler trip intercepts obtained within a selected low probability PSU would get an unusually high weight in the estimation process. Further study should be given to how best to balance the possible advantages of shifting PSU sampling probabilities against the possible disadvantages of creating much greater variability in the weighting of individual angler trip intercepts.

**15. Consider alternative ways to implement the desired stratification of sampling.**

Some combination of “explicit” stratification and “implicit” stratification could be used. Explicit stratification creates disjoint subpopulations (in space and time), each of which is allocated a particular sample size and is sampled independently. This explicitly controls sample size within these spatio-temporal domains. Implicit strata are generally defined within explicit strata based on ordering on other dimensions; by using an ordered sampling algorithm the expected allocation to the implicit strata can be controlled, but the realized allocation may differ from expectation. To

facilitate a simple sample selection scheme, define first-level explicit strata in terms of a geographic coastal area that can be covered by one team of interviewers. Order the PSUs within explicit strata by date and time of day within date. Post stratification at selected margins can be used to tune up the estimates to match known marginal distributions. An example of implicit stratification would be systematic sampling of sites within a spatiotemporal stratum after ordering by latitude. The sample size within a given latitude band would not be explicitly controlled, but there would be good representation of sites across latitudes. In particular, it would not be possible to have only southern sites within a latitude band, which could occur by chance without the implicit stratification.

**16. Consider defining different time intervals for the temporal stratification of sampling in other states.** Time intervals other than the ones used in the NC pilot study may be considered for use in other states. If so, the time interval sizes and boundaries should be chosen to both ensure reasonable sampler productivity while maintaining representative sampling. Implementation of a new intercept survey design will provide site-specific pressure information for various time intervals that could be used to fine-tune the intervals selected for this pilot. Such information may also reveal “dead” times when no intercepts are ever obtained and therefore sampler coverage is not needed (although care should be taken to confirm that this is truly the case and remains so over time). Optimal time intervals may also vary by region or state to reflect the geographic diversity that exists in recreational fisheries.

## 6. Literature Cited

Breidt, F.J., H.L. Lai, J.D. Opsomer, and D. A. Van Voorhees (2011) A Report of the MRIP Sampling and Estimation Project: Improved Estimation Methods for the Access Point Angler Intercept Survey Component of the Marine Recreational Fishery Statistics Survey. [http://www.countmyfish.noaa.gov/projects/downloads/Final%20Report%20of%20New%20Estimation Method for MRFSS Data-01242012.pdf](http://www.countmyfish.noaa.gov/projects/downloads/Final%20Report%20of%20New%20Estimation%20Method%20for%20MRFSS%20Data-01242012.pdf)

Chromy, J.R., S.M. Holland, and R. Webster (2009) Consultant’s Report: For-Hire Recreational Fisheries Surveys. [http://www.countmyfish.noaa.gov/projects/downloads/MRIP\\_FHWG%20ForHire%20Methods%20Review%20Final.pdf](http://www.countmyfish.noaa.gov/projects/downloads/MRIP_FHWG%20ForHire%20Methods%20Review%20Final.pdf)

National Research Council, Committee on the Review of Recreational Fisheries Survey Methods (2006) Review of Recreational Fisheries Survey Methods. 202 pp.  
<http://www.nap.edu/catalog/11616.html>

## **7. Acknowledgements**

The project team would like to thank the following people who all contributed to the success of this project: North Carolina samplers Travis Williams, Kelly Hawk, Jess Hawkins, Jesse Bisette, Jarrod Rabatin, James Woolard, Mary Alice Young, Wes Collett, and Blake Hocker for collecting all the NC Pilot data; Tim Haverland (NOAA Fisheries) for creating the site clustering program; Lauren Dolinger Few (NOAA Fisheries) for facilitating data transfers and formatting files for the clustering program; Laura Johansen (NOAA Fisheries) for performing multiple data analyses; Rebecca Ahrnsbrak (NOAA Fisheries) for producing the catch estimates comparison graphs; Tom Sminkey (NOAA Fisheries) for reviewing this report and providing valuable feedback; and John Foster (NOAA Fisheries) for assisting with development of the sample draw and estimation programs.

Appendix A  
Field Procedures Manual

# **Procedures Manual: Development and Testing of Alternative Sampling Design for the MRFSS Intercept Survey**



North Carolina Division of Marine Fisheries

943 Washington Square Mall  
Washington, NC 27889  
Phone: (800)-338-7804  
Fax: (252)-946-3967

February 2011

 **North Carolina  
Department of Environment  
and Natural Resources**



# **Procedures Manual: Development and Testing of Alternative Sampling Design for the MRFSS Intercept Survey**



National Oceanic and Atmospheric Administration  
National Marine Fisheries Service (NOAA Fisheries)

Office of Science and Technology  
Fisheries Statistics Division, F/ST1  
1315 East-West Highway  
Silver Spring, MD 20910  
Phone: (301)-427-8103

February 2011





## Table of Contents

<b>Chapter 1. Atlantic Intercept survey .....</b>	<b>1</b>
Introduction.....	1
Background.....	1
<b>Chapter 2. Intercept Survey Definitions.....</b>	<b>4</b>
The Interviewer.....	4
The Project Staff.....	4
Wave.....	5
Fishing Mode.....	5
Beach/Bank (BB).....	6
Man-Made (MM).....	6
Private and Rental Boats (PR).....	6
Charter Boats (CH).....	7
Head Boats (HB).....	7
Fishing Sites.....	7
Site Register.....	7
Determining Site Pressures.....	8
Site Description Form.....	10
Adding to, or Deactivating Sites from, the Site Register.....	15
Hostile Sites.....	20
Dealing with Hostility.....	20
<b>Chapter 3. Assignment Distribution .....</b>	<b>21</b>
The Assignment.....	21
How Assignments are Generated and Distributed.....	21
Responsibilities for Assignment Confirmation and Completion.....	22
<b>Chapter 4. Data Collection Procedures for BB, MM, PR, and CH Modes .....</b>	<b>24</b>
Assignment Goals.....	24
Advance Work.....	24
Arrival at the Site.....	24
Equipment Checklist.....	26
Visiting Your Assigned Site.....	26
Cluster Sampling.....	27
Three Site Clusters.....	27
Two Site Clusters.....	28
Single Site Clusters.....	28
Site Closings.....	28
Conducting Counts.....	28
Mode-Specific Procedures for BB, MM, PR, and CH Assignments.....	29
Beach/bank (BB): Assignment Mode 1.....	29
Man-made (MM): Assignment Mode 4.....	29
Private and Rental Boats (PR): Assignment Mode 3.....	29

Charter Boats (CH): Assignment Mode 5.....	30
Tournaments.....	30
<b>Chapter 5. Introducing the Intercept Survey.....</b>	<b>31</b>
Eligibility Requirements .....	31
Determination of a Recreational Angler .....	31
Determination of Saltwater .....	31
Targeting Finfish or Incidental Catch by Shellfishers .....	31
Determination of a Completed Trip .....	32
Canvassing Introduction .....	32
Screening Introduction.....	32
Privacy Act Statement.....	35
<b>Chapter 6. Assignment Summary Form.....</b>	<b>36</b>
Assignment Summary Form .....	36
<b>Chapter 7. The Finfish Intercept Interview .....</b>	<b>46</b>
General Instructions .....	46
Key Items .....	47
Item-by-Item Instruction.....	47
Items Completed by the Interviewer.....	47
Items Asked of the Angler .....	49
<b>Chapter 8. Conducting the Creel Census .....</b>	<b>75</b>
Fish Identification .....	75
Length Measurements .....	79
Weight Measurements.....	80
Calibration and Use of Chatillon Scales .....	81
Care of the Chatillon Scales.....	83
Sub-Sampling Procedure.....	83
<b>Chapter 9. Administrative .....</b>	<b>88</b>
Non-Disclosure Form.....	88
Returning DMF Equipment .....	90
<b>Chapter 10. Interviewing Materials and Supplies .....</b>	<b>91</b>
Bi-Monthly Interviewing Materials and Supplies.....	91
Materials You Need To Return With Each Completed Assignment.....	92
<b>Chapter 11. Quick Tips .....</b>	<b>93</b>

Appendix A: Blank and Example Forms  
Appendix B: Glossary of Terms

# CHAPTER 1. ATLANTIC INTERCEPT SURVEY

## Introduction

We are pleased to provide you with the *2010 Marine Recreational Information Program Pilot Angler Intercept Survey Procedures Manual*. (Throughout this manual, the survey will be referred to as the “MRIP Pilot” or “Pilot Study”). This manual provides all the information needed to conduct the survey and do the best job possible. You are expected to know and understand this document's contents. If you are unclear about a procedural question, use this manual as a reference guide.

Any questions or problems you have which are not covered in this manual should be directed to your field supervisor or other designated point of contact. We expect the interviewers who choose to be part of the MRIP Pilot survey team to share our high level of commitment to scientific excellence. We must never forget that we are involved in the collection of scientific data, and it is up to each of us to recognize the responsibilities inherent in providing the most accurate, valid information possible. We at NC DMF greatly appreciate your willingness to accept this challenge.

---

## Background

NOAA Fisheries, (formerly known as the National Marine Fisheries Service or NMFS) is required to conduct a survey of marine recreational anglers, to gather information about their: (1) catch, participation, and effort in marine recreational fishing, and (2) selected demographic characteristics.

Catch, effort, and participation statistics are fundamental for assessing the influence of fishing on any stock of fish. The quantities taken, the fishing effort, and the seasonal and geographical distribution of the catch and effort are required for the development of rational management policies and plans. Continuous monitoring of catch, effort, and participation is needed to monitor trends, to evaluate the impacts of management regulations, and to project what impacts various management scenarios will have on a fishery.

Accurate, up-to-date catch, effort, and socio-economic statistics collected over the range of a given fishery can be combined with information collected by associated biological studies to provide conservation agencies with the information necessary to manage the fishery for optimum yield. Recreational fisheries data are essential for NOAA Fisheries, the Regional Fishery Management Councils, the Interstate Fisheries Commissions, State conservation agencies, recreational fishing industries, and others involved in the management and productivity of marine fisheries.

The Marine Recreational Fisheries Statistics Survey or “MRFSS”, a nationwide program, was developed in the late 1970s to provide a database of marine recreational fishing

## **Chapter 1. Atlantic Intercept Survey**

---

activity. Originally designed to track trends, the survey has been asked to provide more detailed information for stock assessment and management as required by the Sustainable Fisheries Act and more recently the Magnuson-Stevens Reauthorization Act.

The MRFSS was analyzed by the National Research Council (NRC) in an April 2006 report entitled “Review of Marine Recreational Fishing Survey Methods”. The panel of independent scientists concluded that there are a number of potential biases requiring immediate attention. The Report identified deficiencies in the sampling methodologies and included a lengthy list of recommended changes they felt applied not only to the MRFSS, but also to many of the state-level surveys. NRC recommended NOAA Fisheries and the states rethink the way they conduct recreational fishing surveys to improve their transparency, effectiveness, and applicability to today’s fishery management practices. This Pilot Survey primarily addresses potential biases in the intercept survey with regard to field samplers selecting alternate sites, randomly selecting anglers for interviewing, and in determining arrival and departure times of assignments.

Starting in 2010, the MRFSS survey is being phased out under a new initiative known as the Marine Recreational Information Program (MRIP). The goals of the new initiative are to increase coverage and efficiency while decreasing the potential for statistical bias within the survey design. The program consists of several independent, yet complementary surveys. The principal components are:

- ✓ An access-point intercept survey, which is designed to assess catch per unit effort in all fishing modes. Your work will be instrumental in supporting this part of the project!
- ✓ The Coastal Household Telephone Survey (CHTS), which is designed to assess shore and private boat fishing effort by coastal county residents; and
- ✓ The For-Hire Survey (FHS), which is designed to assess charter and head boat fishing effort.

Data from the component surveys are combined to estimate total fishing effort, participation, and catch by species.

The CHTS is used to estimate the total number of marine recreational fishing trips taken by residents of coastal areas. Data from the CHTS and the intercept survey are combined to provide an estimate of the total catch of marine recreational anglers by species. Although the principal purpose of the Intercept survey is to obtain catch data, several questions in the survey provide vital information for the expansion and precise estimation of effort produced by the CHTS.

The FHS is a directory-based telephone survey of for-hire fishing vessels. Using state directories of for-hire vessels, vessels are categorized as either charter or head boats, and sampled weekly. Representatives from selected vessels are contacted by telephone to answer questions about their fishing effort in the previous week. The sample frame, or current list of active and eligible vessels, is used to expand the effort estimate obtained from the telephone survey.

## **Chapter 1. Atlantic Intercept Survey**

---

The goal of the Pilot Study is to test new data collection methodologies for the intercept survey that will be applicable to other coastal regions including the Atlantic, Gulf of Mexico, and Pacific coasts, as well as Hawaii.

While the MRFSS, and the Pilot Study, ultimately include a series of complementary surveys, the North Carolina pilot project will include only the intercept portion of the survey.

# CHAPTER 2. INTERCEPT SURVEY DEFINITIONS

## The Interviewer

The key to accurate data collection begins with you, the interviewer. The interviewer plays a vital role in this project, and therefore high-quality interviewing is essential. A good interviewer identifies fish accurately at the species level, approaches strangers easily, meticulously follows procedures, completes forms with accuracy and precision, and diplomatically handles sensitive situations. The intercept interview involves both a face-to-face interview and a creel census (identification and measurement of the catch), where a unique set of skills is required for each.

As an Atlantic Intercept Survey interviewer, you are required to:

- ✓ Complete site assignments following specified protocol and have all equipment available and in proper working order (e.g., properly calibrated scales).
- ✓ Conduct interviews in a professional manner, complete all forms accurately, and submit all forms on-time.
- ✓ Wear appropriate attire and present yourself in a professional manner.
- ✓ Submit site description information to be used in the site sampling process.
- ✓ Provide timely information on the completion and productivity of each assignment.
- ✓ Always keep in mind that the focus of this survey is the **assignment**, and not the angler or catch; in other words, the anglers or their catch (or lack of) must not dictate who gets interviewed.

Interviewers must always keep in mind that their performance impacts the reputation of the survey, and also reflects on the NC DMF and NOAA Fisheries. Please remember that at no time should you claim that you are an employee of NOAA Fisheries. Interviewers should say they are (contractor / state agency) employees collecting data for a survey sponsored by NOAA Fisheries.

## The Project Staff

Each interviewer will work with designated project staff members located in the NC DMF Washington Regional office (WARO). Staff are involved in interviewer training, supervision, and quality control procedures; assignment scheduling, rescheduling, and tracking sampling progress; and updating the site description files using the site information provided by the interviewers. In addition, you should call staff if you have questions about procedures, fish identification, or an interviewing site.

Upon successful completion of initial interviewer training, project staff is required to conduct additional testing and training of interviewers in the field. Each new interviewer must be observed in the field for the first few assignments and at least once during each successive six-month period following his/her initial field observation. In addition, supplemental training and field observations of new interviewers are required until project staff feels confident that the interviews are being conducted completely,

## **Chapter 2. Intercept Survey Definitions**

---

consistently, accurately, and in accordance with the standard procedures in this manual. Project staff will focus on the interviewer's ability to follow proper procedures locating themselves at a particular site and moving from site to site within a cluster, deal effectively with people, properly conduct interviews, accurately code interview forms, and correctly identify, weigh, and measure fish.

In addition to field visits, DMF staff will conduct several meetings each year. Interviewers are expected to attend all meetings. During these meetings, staff will discuss new procedural issues (if any) and reviews existing ones. Staff will administer two tests during these meetings. The first is a fish test to monitor each interviewer's identification skills, and the second is a procedural test to ensure each interviewer has read the manual and understands procedures. Because this is a Pilot Study, the importance of following established procedures cannot be overstated.

Interviewers work with project staff on issues concerning procedures, coding forms, and administrative issues. You should also contact your field supervisor if you have questions or problems with your equipment, or if you are running low on interviewing supplies.

All completed interviews from each interviewer will be reviewed for accuracy, completeness, legibility, and consistency of coding by project staff. The interviewer will receive feedback on his/her performance in this area.

### **Wave**

Data collection is structured around two-month periods called "waves." January and February represent Wave 1, March and April represent Wave 2, etc.

- Wave 1: January and February
- Wave 2: March and April
- Wave 3: May and June
- Wave 4: July and August
- Wave 5: September and October
- Wave 6: November and December

### **Fishing Mode**

The Atlantic Intercept Survey is also structured around types or "modes" of fishing. While there are many types of fishing, four major mode groups are considered in this pilot: beach/bank fishing (BB); man-made fishing (MM); private and rental boat fishing (PR); and charter boat fishing (CH). A fifth type of mode, head boat fishing, will not be sampled for this pilot, but will be addressed outside of this project. Note that the Atlantic Intercept Survey uses different codes to refer to the mode of fishing and to the mode of an interviewing assignment. Interviewing assignment codes are discussed below.

More exact definitions for **fishing** modes are:

## **Chapter 2. Intercept Survey Definitions**

---

### **Beach/Bank (BB)**

**Breachway:** A natural or man-made inlet that cuts through a barrier island or beach. It connects the coastal lagoon to the ocean.

**Beach:** A stretch of pebbles or sand beside a body of water, often washed by high water.

**Bank:** A stretch of rising land at the edge of a body of water not washed by high water, which could be rocks or an overhanging cliff.

### **Man-Made (MM)**

**Pier:** A platform extending from a shore over water and supported by pillars, without long-term docking facilities for boats.

**Dock:** A structure built out over water and supported by pillars/anchors, with long-term docking facilities for boats.

**Jetty:** A structure of stone or concrete which extends from shore into the water to restrain currents or protect a harbor.

**Breakwater:** A barrier or offshore structure that protects a harbor or shore from the full impact of waves.

**Bridge:** A structure spanning, and providing passage over, water.

**Causeway:** A raised roadway that spans across water or marshland.

**Other:** Any other non-boat fishing (e.g., a boat ramp.)

### **Private and Rental Boats (PR)**

**Private Boat:** A boat belonging to an individual.

**Rental Boat:** A boat that is rented or leased. No captain or crew is provided; the renter operates the boat.

- A canoe and/or a kayak are two different types of boats that are often seen out in the field. Keep in mind that it does not matter what type of boat the angler is fishing from; what matters more is if the vessel is a private boat or a rented one.



## Chapter 2. Intercept Survey Definitions

---

### Charter Boats (CH)

**Charter Boat:** A boat operated by a licensed captain and crew where the anglers are part of a pre-formed group that has paid a fee for the captain's services for a specific date and time. The number of anglers in the pre-formed group is usually less than seven, but could be up to 30 or more. The key is that these trips are private, and individual anglers do not just show up to join the trip. Charters are usually closed parties, as opposed to the open party status of head boats. These are sometimes called guide boats, and may be small boats fishing inside waters with two to three clients. Charter boats can engage in a full range of fishing techniques, including trolling, bottom fishing, and drift fishing. Charter boats may make all-day or half-day trips.

### Head Boats (HB)

**Head Boat:** A boat operated by a licensed captain and crew where individuals or small groups of anglers pay a fee for fishing. The anglers usually do not know everyone on the boat, and a minimum number of anglers are required prior to launch. In this case, any angler can reserve a space, or show up on the day of the trip to join. The vessel is operated by a licensed captain (guide or skipper) and crew, and almost always carries seven or more passengers. In some areas of the country, head boats are called "open party boats" or "party boats" for short. Head boats may make all-day or half-day trips. **You will not be conducting HB interviews as part of the MRIP pilot project survey.**

### Fishing Sites

Since this survey focuses on saltwater recreational fin-fishing, all sites are discrete geographical areas from which this activity takes place. With the possible exception of some beach/bank sites, a fishing site should not include more than approximately 100 yards of coastline area. That is, one interviewer should be able to cover an entire site on foot in a reasonable amount of time. Some beach/bank sites can be larger than 100 yards, but boundaries should be clearly identified in the site register. A site does not have to be as large as 100 yards if smaller boundaries are appropriate.

A fishing site can have more than one mode of fishing. A docking area with both charter boats and private boats is one site with both charter fishing and private/rental fishing. If people occasionally fish from the dock itself, the site register will also show shore fishing activity for that site. However, during your assignment, you will collect interviews only in the mode of fishing designated for that assignment.

### Site Register

The Site Register (SR) is a database of all saltwater recreational fin-fishing locations in each state. Sites are grouped together to create sampling clusters of up to three sites per cluster. Only one cluster is sampled per assignment.

## Chapter 2. Intercept Survey Definitions

---

Information provided for each site in the SR includes a two-digit state code, a three-digit county code, and a four-digit site code unique to each site. These codes are followed by a description of the site and its location. Each site description includes the name of the nearest town, directions from a starting point (such as a recognizable landmark or intersection), and, if available, the name and phone number of a primary contact person who supervises the site. Sites are listed in numerical order by county, but are not in any geographical order. Each interviewer will be given a SR for his/her state at the beginning of each wave.

### Determining Site Pressures

The Site Register includes an estimate of the monthly weekday and weekend fishing pressure at each site for each mode within one of four six-hour time frames. The fishing pressure is the mode- site- and time-specific average number of anglers expected to fish over a specific six-hour period on an average day, expressed as a categorical value. The value must be representative of the average daily activity over a given month for each time interval and kind of day (weekend or weekday). Fishing pressures are used to determine sampling probabilities for each site and are updated each wave.

Pressure categories are:

Pressure Code	Average Number of Eligible Anglers
0	1 – 4
1	5 – 8
2	9 – 12
3	13 – 19
4	20 – 29
5	30 – 49
6	50 – 79
7	80 +
8	Can't determine
9	Mode not present

**It is important that interviewers use up-to-date Site Registers, as these registers are updated prior to every wave.**

If the site has any type of shore fishing, one of the following indicators is listed with the description for that site. (Sites with no shore fishing will have an "NA" indicator, representing "Not Applicable.")

**MM:** Man-Made shore only.

**BB:** Beach/Bank only.

**SH:** Both Man-Made shore and Beach/Bank.

## Chapter 2. Intercept Survey Definitions

**Figure 2.1: Site Register excerpt**

Excerpt from Master Site Register for the State of Georgia													
County/ Site	Site Description	Pressure Data											
		Jan	Feb	Mar	Apr	May	Jun	Jul	Aug	Sep	Oct	Nov	Dec
County 029 Site 0047	Site Name: KILKENNY FISH CAMP City/Town: RICHMOND HILL Direct: TAKE EXIT 90 EAST ON GA HWY 144 FOR 12.5 MILES. TURN LEFT ON KILKENNY ROAD, FOLLOW 2.9 MILES UNTIL PAVEMENT ENDS. FOLLOW DIRT ROAD FOR 0.1 MILES TO FISH CAMP. Notes: VESSEL LAUNCH FEE DETERMINED BY LENGTH OF VESSEL Access: Public Fee: Y Safe: N Lat: 31:47:17 Long: 81:12:11 Total # Charter Boats: 2 Total # Headboats: 0 Night Fishing: NP SHmode: NA Phone: 912 727 2215 Contact: MR. ROBERT BACOT	WE 9020	9020	9020	9020	9020	9030	9030	9030	9030	9030	9030	9020
		WD 9000	9000	9010	9010	9010	9010	9010	9010	9010	9010	9000	9000
County 029 Site 0127	Site Name: DEMERIES CREEK RAMP & DOCK City/Town: RICHMOND HILL Direct: TAKE EXIT 90 EAST ON GA HWY 144 FOR 14.1 MILES. RAMP LOCATED ON THE RIGHT JUST BEFORE THE GEORGIA DEPARTMENT OF NATURAL RESOURCES LAW ENFORCEMENT OFFICE Notes: NO CH PRESSURE BUT 1 TRAILERED CH Access: Public Fee: N Safe: N Lat: 31:47:06 Long: 81:15:14 Total # Charter Boats: 0 Total # Headboats: 0 Night Fishing: NP SHmode: NA Phone: 912 727 2215 Contact: DNR GAME & FISH	WE 9909	9909	9919	9919	9929	9929	9929	9929	9919	9919	9919	9919
		WD 9909	9909	9909	9909	9909	9909	9909	9909	9909	9909	9909	9909
County 029 Site 0135	Site Name: TIVOLI RIVER FISHING PIER City/Town: RICHMOND HILL Direct: TAKE EXIT 90 EAST ON GA HWY 144 FOR 10.1 MILES TURN RIGHT ON BELFAST ROAD (LOOK FOR FORESTRY TOWER). 1.9 MILES TO TIVOLI RIVER Notes: Access: Public Fee: N Safe: N Lat: 31:50:24 Long: 81:16:01 Total # Charter Boats: 0 Total # Headboats: 0 Night Fishing: SH SHmode: SH Phone: N/A Contact: N/A	WE 0999	0999	0999	0999	0999	0999	0999	0999	0999	0999	0999	0999
		WD 0999	0999	0999	0999	0999	0999	0999	0999	0999	0999	0999	0999
County 029 Site 0170 Deleted	Site Name: OGEECHEE RIVER BANK City/Town: RICHMOND HILL Direct: EAST ON 144, LEFT ON 144 SPUR--NEAR FT McALLISTER Notes: Access: Public Fee: N Safe: N Lat: 31:53:20 Long: 81:12:11 Total # Charter Boats: 0 Total # Headboats: 0 Night Fishing: PR SHmode: NA Phone: N/A Contact: N/A	WE 9999	9999	9999	9999	9999	9999	9999	9999	9999	9999	9999	9999
		WD 9999	9999	9999	9999	9999	9999	9999	9999	9999	9999	9999	9999
Notes:		0 = 1-4		1 = 5-8		2 = 9-12		3 = 13-19					
Pressure data includes SH, PC, PR and CH values for weekends (WE) and weekdays (WD). Pressure values are as follows:		4 = 20-29		5 = 30-49		6 = 50-79		7 = 80+					
		8 = Cannot determine activity		9 = Mode not present at site									

## Chapter 2. Intercept Survey Definitions

### Site Description Form

The Site Description Form (SDF) is used to update site information, including fishing pressure for the current wave. The guidelines provided for completing this form are keyed to the form's section numbers. When completing any form, please fill in all sections of the form, and write clearly. An example of the completed form is shown in Figure 2.2 on page 14.

**(1) General Information** — Fill in your *interviewer ID number(s)*, *date*, *state*, *county*, *site number* (if it is an existing site), *latitude*, and *longitude* (coordinates should be recorded from the GPS unit in dd:mm:ss.s, record the location (e.g. foot of pier) in the “Comments”). If it is a new site check the *new site* box. Complete the *weather conditions* box (mark one box per column) for the overall conditions during the time spent on site.

<input type="text"/>	<input type="text"/>	<input type="text"/>	<input type="text"/>	1 <sup>ST</sup> INTERVIEWER	<b>2010 SITE DESCRIPTION FORM</b>				STATE	<input type="text"/>	<input type="text"/>
<input type="text"/>	<input type="text"/>	<input type="text"/>	<input type="text"/>	2 <sup>ND</sup> INTERVIEWER					COUNTY	<input type="text"/>	<input type="text"/>
<input type="text"/>	<input type="text"/>	<input type="text"/>	<input type="text"/>	<input type="text"/>	<input type="text"/>	<input type="text"/>	<input type="text"/>	YYYY MM DD	SITE	<input type="text"/>	<input type="text"/>
WEATHER CONDITIONS (ONE PER COLUMN)	<input type="checkbox"/>	CLEAR	<input type="checkbox"/>	NO WIND (0 KNOTS)	<input type="checkbox"/>	NO PRECIPITATION	LATITUDE N <input type="text"/> : <input type="text"/> : <input type="text"/> . <input type="text"/>				
	<input type="checkbox"/>	PARTLY CLOUDY	<input type="checkbox"/>	BREEZY (1- 16 KNOTS)	<input type="checkbox"/>	RAIN	LONGITUDE W <input type="text"/> : <input type="text"/> : <input type="text"/> . <input type="text"/>				
	<input type="checkbox"/>	CLOUDY	<input type="checkbox"/>	WINDY (17-33 KNOTS)	<input type="checkbox"/>	SNOW	NEW SITE <input type="checkbox"/>				
	<input type="checkbox"/>		<input type="checkbox"/>	STRONG WIND (34+ KNOTS)	<input type="checkbox"/>	MIX					

### (2) Site Directions and Contact Information

*Site Name:* Site names should be brief but at the same time descriptive enough to differentiate the site from any other site in that state. Include additional comments if the site has no proper name.

*Site Street Address:* (e.g., 100 4th Street.) If there is no address, choose the closest building with a street address and write it down. If an address is not possible, a location is needed (e.g., 4th Street and Pine.) **If descriptive information must be used instead of an exact address, indicate this on the form.**

Site City/Town, State and ZIP code.

*Contact Person and Phone Number.* Make an effort to obtain this information; please verify the information even if it is an existing site.

## Chapter 2. Intercept Survey Definitions

---

*Directions from a major highway.* If the site does not have a street number or address, and it is near or adjacent to an existing site on the Site Register with specific directions (e.g., street number or address), you may indicate directions from that existing site. With all directions, remember to state the direction (North, South, East, or West) for all turns and streets.

SITE NAME \_\_\_\_\_

STREET ADDRESS \_\_\_\_\_

CITY \_\_\_\_\_ STATE   ZIP

CONTACT NAME \_\_\_\_\_ PHONE

DIRECTIONS FROM MAJOR HIGHWAY \_\_\_\_\_

\_\_\_\_\_

\_\_\_\_\_

\_\_\_\_\_

\_\_\_\_\_

### (3) Site Description

*Modes Present at the Site:* For each mode, indicate whether the mode is present, not present, or if you are unable to make this determination. **Do not leave any mode unchecked.**

*Night Fishing:* Note that there are separate categories to indicate if night fishing is present for all modes. If so, also check whether there is *adequate lighting* and if the site is *safe at night* to conduct interviews after dark.

*Fee for use of site:* Check the appropriate box to indicate if the site charges any types of fees to the public for use of the site, such as an entrance fee or a boat launching fee. If possible, please indicate the amount of the fee on the form, if one is charged. Note that this pertains only to whether or not the public must pay a fee and has nothing to do with whether or not an interviewer must pay the fee.

*Private Access:* Check the appropriate box if the site is closed to the general public. In addition, check whether we have permission to interview (“*can we interview*”) at the site if it is private. There may be instances when a privately-owned site may not welcome our interviewers. If this is the case, please indicate this on the form.

*Tide:* If the fishing pressure would be affected greatly by the tidal cycle, please check "yes" and explain in the comments section at the bottom of the site description form (e.g., a pier left exposed at low tide affecting MM mode; a boat ramp inaccessible at low tide affecting PR mode).

## Chapter 2. Intercept Survey Definitions

*Number of Charter/Head Boats:* Please indicate the total number of charter and head boats that use this site. Estimate this number by counting the number of assigned wet or storage slips used by each vessel type (ask the dock master for count of the storage slips if they are in boat sheds or dry storage sheds). If the site contains charter boats that launch from the site via trailers, estimate the total number of charter boats that would launch on an average fishing day using information from reputable sources, such as a dock master, at the site.

### MODES PRESENT/SITE ATTRIBUTES

	YES	NO	CANNOT DETERMINE		YES	NO	CANNOT DETERMINE		YES	NO	CANNOT DETERMINE
MAN-MADE	<input type="checkbox"/>	<input type="checkbox"/>	<input type="checkbox"/>	NIGHT FISHING MM?	<input type="checkbox"/>	<input type="checkbox"/>	<input type="checkbox"/>	PRIVATE ACCESS?	<input type="checkbox"/>	<input type="checkbox"/>	<input type="checkbox"/>
BEACH/BANK	<input type="checkbox"/>	<input type="checkbox"/>	<input type="checkbox"/>	NIGHT FISHING PR?	<input type="checkbox"/>	<input type="checkbox"/>	<input type="checkbox"/>	CAN WE INTERVIEW?	<input type="checkbox"/>	<input type="checkbox"/>	<input type="checkbox"/>
HEAD BOAT	<input type="checkbox"/>	<input type="checkbox"/>	<input type="checkbox"/>	NIGHT FISHING CH?	<input type="checkbox"/>	<input type="checkbox"/>	<input type="checkbox"/>	FISHING PRESSURE AFFECTED BY TIDE?	<input type="checkbox"/>	<input type="checkbox"/>	<input type="checkbox"/>
CHARTER BOAT	<input type="checkbox"/>	<input type="checkbox"/>	<input type="checkbox"/>	ADEQUATE LIGHTING?	<input type="checkbox"/>	<input type="checkbox"/>	<input type="checkbox"/>	# HB USING SITE	<input type="text"/>	<input type="text"/>	
PRIVATE/RENTAL BOAT	<input type="checkbox"/>	<input type="checkbox"/>	<input type="checkbox"/>	SAFE AT NIGHT?	<input type="checkbox"/>	<input type="checkbox"/>	<input type="checkbox"/>	# CH USING SITE	<input type="text"/>	<input type="text"/>	
NIGHT FISHING BB?	<input type="checkbox"/>	<input type="checkbox"/>	<input type="checkbox"/>	COMMERCIAL FEE FOR USE OF SITE? (EX: ENTRANCE/LAUNCHING/PARKING FEE.)	<input type="checkbox"/>	<input type="checkbox"/>	<input type="checkbox"/>				

**(4) Pressure Estimates for BB, MM, CH, and PR sites** — The fishing pressure is the mode-, time interval-, and site-specific average number of anglers expected to use that mode and site over a six-hour period on an average day, expressed in the Site Register as a categorical value. The value must be representative of the average daily activity over the entire month. Separate pressure ratings are given for weekdays and average weekend days in each fishing mode for each month of the year as well as for each separate six-hour time interval.

Using the numerical codes provided on the SDF, estimate the fishing pressure for each mode for months of the current wave (be sure to mark the time interval you are evaluating). Fill in the calendar month in the space provided (e.g., in Wave 2, March is Month 1 and April is Month 2).

## Chapter 2. Intercept Survey Definitions

---

### PRESSURE ESTIMATES

9 = 0 ANGLERS/MODE NOT PRESENT	3 = 13-19 ANGLERS	6 = 50-79 ANGLERS
0 = 1-4 ANGLERS	4 = 20-29 ANGLERS	7 = 80+ ANGLERS
1 = 5-8 ANGLERS	5 = 30-49 ANGLERS	8 = CANNOT DETERMINE
2 = 9-12 ANGLERS		

**THIS WAVE:**

WHAT IS YOUR ESTIMATE OF THE NUMBER OF ELIGIBLE ANGLERS EXPECTED DURING A SIX-HOUR PERIOD OF WEEKEND/WEEKDAY ACTIVITY FOR EACH MONTH OF THIS WAVE?

MONTH 1: \_\_\_\_\_

WEEKEND				TIME PERIOD		WEEKDAY				TIME PERIOD							
BB	MM	CH	PR	<input type="checkbox"/>	<input type="checkbox"/>	BB	MM	CH	PR	<input type="checkbox"/>	<input type="checkbox"/>						
<input type="text"/>	<input type="text"/>	<input type="text"/>	<input type="text"/>	<input type="checkbox"/>	0200-0800	<input type="checkbox"/>	<input type="checkbox"/>	0800-1400	<input type="checkbox"/>	<input type="checkbox"/>	0200-0800	<input type="checkbox"/>	<input type="checkbox"/>	0800-1400			
<input type="text"/>	<input type="text"/>	<input type="text"/>	<input type="text"/>	<input type="checkbox"/>	1400-2000	<input type="checkbox"/>	<input type="checkbox"/>	2000-0200	<input type="checkbox"/>	<input type="checkbox"/>	<input type="checkbox"/>	<input type="checkbox"/>	<input type="checkbox"/>	1400-2000	<input type="checkbox"/>	<input type="checkbox"/>	2000-0200

MONTH 2: \_\_\_\_\_

WEEKEND				TIME PERIOD		WEEKDAY				TIME PERIOD							
BB	MM	CH	PR	<input type="checkbox"/>	<input type="checkbox"/>	BB	MM	CH	PR	<input type="checkbox"/>	<input type="checkbox"/>						
<input type="text"/>	<input type="text"/>	<input type="text"/>	<input type="text"/>	<input type="checkbox"/>	0200-0800	<input type="checkbox"/>	<input type="checkbox"/>	0800-1400	<input type="checkbox"/>	<input type="checkbox"/>	0200-0800	<input type="checkbox"/>	<input type="checkbox"/>	0800-1400			
<input type="text"/>	<input type="text"/>	<input type="text"/>	<input type="text"/>	<input type="checkbox"/>	1400-2000	<input type="checkbox"/>	<input type="checkbox"/>	2000-0200	<input type="checkbox"/>	<input type="checkbox"/>	<input type="checkbox"/>	<input type="checkbox"/>	<input type="checkbox"/>	1400-2000	<input type="checkbox"/>	<input type="checkbox"/>	2000-0200

**(5) Comments** — Use this section to clarify the information recorded earlier, and to provide any additional information that may assist future interviewers working at that site.

**Example Forms:** Completed SDF forms are provided on the following pages.

## Chapter 2. Intercept Survey Definitions

**Figure 2.2: Example of a Completed Site Description Form**

1<sup>ST</sup> INTERVIEWER    **2010 SITE DESCRIPTION FORM**    STATE

2<sup>ND</sup> INTERVIEWER    COUNTY

YYYY MM DD    SITE

WEATHER CONDITIONS (ONE PER COLUMN)	<input checked="" type="checkbox"/> CLEAR	<input type="checkbox"/> NO WIND (0 KNOTS)	<input checked="" type="checkbox"/> NO PRECIPITATION
	<input type="checkbox"/> PARTLY CLOUDY	<input checked="" type="checkbox"/> BREEZY (1-16 KNOTS)	<input type="checkbox"/> RAIN
	<input type="checkbox"/> CLOUDY	<input type="checkbox"/> WINDY (17-33 KNOTS)	<input type="checkbox"/> SNOW
	<input type="checkbox"/> STRONG WIND (34+ KNOTS)	<input type="checkbox"/> MIX	

LATITUDE N   :   :   .

LONGITUDE W   :   :   .

NEW SITE

SITE NAME Fisherman's Wharf

STREET ADDRESS 127 Main St.

CITY Chincoteague STATE  ZIP

CONTACT NAME John Smith PHONE

DIRECTIONS FROM MAJOR HIGHWAY From Route 13, head east on route 175 (Chincoteague Rd), drive about 10 miles to Main St and turn left.

### MODES PRESENT/SITE ATTRIBUTES

	YES	NO	CANNOT DETERMINE		YES	NO	CANNOT DETERMINE		YES	NO	CANNOT DETERMINE
MAN-MADE	<input checked="" type="checkbox"/>	<input type="checkbox"/>	<input type="checkbox"/>	NIGHT FISHING MM?	<input type="checkbox"/>	<input checked="" type="checkbox"/>	<input type="checkbox"/>	PRIVATE ACCESS?	<input type="checkbox"/>	<input checked="" type="checkbox"/>	<input type="checkbox"/>
BEACH/BANK	<input checked="" type="checkbox"/>	<input type="checkbox"/>	<input type="checkbox"/>	NIGHT FISHING PR?	<input checked="" type="checkbox"/>	<input type="checkbox"/>	<input type="checkbox"/>	CAN WE INTERVIEW?	<input checked="" type="checkbox"/>	<input type="checkbox"/>	<input type="checkbox"/>
HEAD BOAT	<input type="checkbox"/>	<input checked="" type="checkbox"/>	<input type="checkbox"/>	NIGHT FISHING CH?	<input checked="" type="checkbox"/>	<input type="checkbox"/>	<input type="checkbox"/>	FISHING PRESSURE AFFECTED BY TIDE?	<input type="checkbox"/>	<input checked="" type="checkbox"/>	<input type="checkbox"/>
CHARTER BOAT	<input checked="" type="checkbox"/>	<input type="checkbox"/>	<input type="checkbox"/>	ADEQUATE LIGHTING?	<input checked="" type="checkbox"/>	<input type="checkbox"/>	<input type="checkbox"/>	# HB USING SITE	<input type="text" value="0"/> <input type="text" value="0"/>		
PRIVATE/RENTAL BOAT	<input checked="" type="checkbox"/>	<input type="checkbox"/>	<input type="checkbox"/>	SAFE AT NIGHT?	<input checked="" type="checkbox"/>	<input type="checkbox"/>	<input type="checkbox"/>	# CH USING SITE	<input type="text" value="0"/> <input type="text" value="3"/>		
NIGHT FISHING BB?	<input type="checkbox"/>	<input checked="" type="checkbox"/>	<input type="checkbox"/>	COMMERCIAL FEE FOR USE OF SITE? (EX: ENTRANCE/LAUNCHING/PARKING FEE.)	<input checked="" type="checkbox"/>	<input type="checkbox"/>	<input type="checkbox"/>				



## Chapter 2. Intercept Survey Definitions

### PRESSURE ESTIMATES

9 = 0 ANGLERS/MODE NOT PRESENT	3 = 13-19 ANGLERS	6 = 50-79 ANGLERS
0 = 1-4 ANGLERS	4 = 20-29 ANGLERS	7 = 80+ ANGLERS
1 = 5-8 ANGLERS	5 = 30-49 ANGLERS	8 = CANNOT DETERMINE
2 = 9-12 ANGLERS		

#### THIS WAVE:

WHAT IS YOUR ESTIMATE OF THE NUMBER OF ELIGIBLE ANGLERS EXPECTED DURING A SIX-HOUR PERIOD OF WEEKEND/WEEKDAY ACTIVITY FOR EACH MONTH OF THIS WAVE?

MONTH 1: June

WEEKEND				TIME PERIOD	
BB	MM	CH	PR	<input type="checkbox"/> 0200-0800	<input type="checkbox"/> 0800-1400
1	1	2	2	<input checked="" type="checkbox"/> 1400-2000	<input type="checkbox"/> 2000-0200

WEEKDAY				TIME PERIOD	
BB	MM	CH	PR	<input type="checkbox"/> 0200-0800	<input type="checkbox"/> 0800-1400
1	1	0	0	<input checked="" type="checkbox"/> 1400-2000	<input type="checkbox"/> 2000-0200

MONTH 2: July

WEEKEND				TIME PERIOD	
BB	MM	CH	PR	<input type="checkbox"/> 0200-0800	<input type="checkbox"/> 0800-1400
2	2	3	3	<input checked="" type="checkbox"/> 1400-2000	<input type="checkbox"/> 2000-0200

WEEKDAY				TIME PERIOD	
BB	MM	CH	PR	<input type="checkbox"/> 0200-0800	<input type="checkbox"/> 0800-1400
2	2	1	1	<input checked="" type="checkbox"/> 1400-2000	<input type="checkbox"/> 2000-0200

COMMENTS: New contact name and number.  
Entrance fee is \$3, launch fee is \$5  
No night fishing in MM and BB modes  
because parking lot closes at 6 pm.

### Adding to, or Deactivating Sites from, the Site Register

New sites should be discovered rarely, however, when a new site is encountered, the interviewer should complete a SDF with the best estimate of fishing pressure for all months indicated. If possible, the interviewer should talk to site personnel and attempt to include monthly pressure estimates for the remainder of the year. (Note that since the form has space for only two months, if you include pressure estimates for the entire year you should do so using the "comments" section.) The site number should be left blank, and the interviewer should provide an explanation as to why the site should be added. The interviewer should also indicate that a new site was visited by checking the "NEW SITE" box.

If during an assignment the interviewer visits a site that turns out to be inactive (e.g., an establishment has gone out of business), he/she should fill out a SDF and clearly mark it as an "INACTIVE SITE" at the top of the form. The interviewer should provide an explanation as to why the site should be deactivated. Do not 9-out the pressures since historical information must be left intact. An example illustrating this procedure is shown in Figure 2.4.

NOTE: Sites marked as "INACTIVE" will not be assigned to interviewers.

## **Chapter 2. Intercept Survey Definitions**

---

Please note that sites are NEVER removed from the Site Register. Inactive sites are kept on the Site Register (with historical pressures left intact) but are coded with a “D” printed in bold type to indicate the site has been deactivated. This allows for re-activation of the site in the future and to keep site codes unique to a geographic site. Interviewers are encouraged to inform their project staff if they learn that a previously inactive site has become active.

## Chapter 2. Intercept Survey Definitions

**Figure 2.3: Site Description Form — Adding a New Site**

1 2 3 4 1<sup>ST</sup> INTERVIEWER **2010 SITE DESCRIPTION FORM** STATE 5 1

2<sup>ND</sup> INTERVIEWER COUNTY 8 1 0

2 0 1 0 1 1 1 2 YYYY MM DD SITE

WEATHER CONDITIONS (ONE PER COLUMN)  CLEAR  NO WIND (0 KNOTS)  NO PRECIPITATION  
 PARTLY CLOUDY  BREEZY (1-16 KNOTS)  RAIN  
 CLOUDY  WINDY (17-33 KNOTS)  SNOW  
 STRONG WIND (34+ KNOTS)  MIX

LATITUDE N 3 6 : 4 7 : 1 0 . 1  
 LONGITUDE W 7 5 : 5 3 : 2 1 . 3

NEW SITE

SITE NAME 14th Street Fishing Pier

STREET ADDRESS 201 14th Street

CITY Virginia Beach STATE VA ZIP 23451

CONTACT NAME Joe Angler PHONE 757 555 1222

DIRECTIONS FROM MAJOR HIGHWAY From US 58 (Virginia Beach Blvd) turn right (south) on 15th Street. Drive about a half mile and turn left on Atlantic Avenue. Parking lot is on the right.

### MODES PRESENT/SITE ATTRIBUTES

	YES	NO	CANNOT DETERMINE		YES	NO	CANNOT DETERMINE		YES	NO	CANNOT DETERMINE
MAN-MADE	<input checked="" type="checkbox"/>	<input type="checkbox"/>	<input type="checkbox"/>	NIGHT FISHING MM?	<input checked="" type="checkbox"/>	<input type="checkbox"/>	<input type="checkbox"/>	PRIVATE ACCESS?	<input type="checkbox"/>	<input checked="" type="checkbox"/>	<input type="checkbox"/>
BEACH/BANK	<input type="checkbox"/>	<input checked="" type="checkbox"/>	<input type="checkbox"/>	NIGHT FISHING PR?	<input type="checkbox"/>	<input checked="" type="checkbox"/>	<input type="checkbox"/>	CAN WE INTERVIEW?	<input checked="" type="checkbox"/>	<input type="checkbox"/>	<input type="checkbox"/>
HEAD BOAT	<input type="checkbox"/>	<input checked="" type="checkbox"/>	<input type="checkbox"/>	NIGHT FISHING CH?	<input type="checkbox"/>	<input checked="" type="checkbox"/>	<input type="checkbox"/>	FISHING PRESSURE AFFECTED BY TIDE?	<input type="checkbox"/>	<input checked="" type="checkbox"/>	<input type="checkbox"/>
CHARTER BOAT	<input type="checkbox"/>	<input checked="" type="checkbox"/>	<input type="checkbox"/>	ADEQUATE LIGHTING?	<input checked="" type="checkbox"/>	<input type="checkbox"/>	<input type="checkbox"/>	# HB USING SITE	<input type="text" value="0"/>	<input type="text" value="0"/>	
PRIVATE/RENTAL BOAT	<input type="checkbox"/>	<input checked="" type="checkbox"/>	<input type="checkbox"/>	SAFE AT NIGHT?	<input checked="" type="checkbox"/>	<input type="checkbox"/>	<input type="checkbox"/>	# CH USING SITE	<input type="text" value="0"/>	<input type="text" value="0"/>	
NIGHT FISHING BB?	<input type="checkbox"/>	<input checked="" type="checkbox"/>	<input type="checkbox"/>	COMMERCIAL FEE FOR USE OF SITE? (EX: ENTRANCE/LAUNCHING/PARKING FEE.)	<input checked="" type="checkbox"/>	<input type="checkbox"/>	<input type="checkbox"/>				

## Chapter 2. Intercept Survey Definitions

### PRESSURE ESTIMATES

9 = 0 ANGLERS/MODE NOT PRESENT	3 = 13-19 ANGLERS	6 = 50-79 ANGLERS
0 = 1-4 ANGLERS	4 = 20-29 ANGLERS	7 = 80+ ANGLERS
1 = 5-8 ANGLERS	5 = 30-49 ANGLERS	8 = CANNOT DETERMINE
2 = 9-12 ANGLERS		

**THIS WAVE:**

WHAT IS YOUR ESTIMATE OF THE NUMBER OF ELIGIBLE ANGLERS EXPECTED DURING A SIX-HOUR PERIOD OF WEEKEND/WEEKDAY ACTIVITY FOR EACH MONTH OF THIS WAVE?

MONTH 1: November

WEEKEND				TIME PERIOD		WEEKDAY				TIME PERIOD	
BB	MM	CH	PR	<input type="checkbox"/> 0200-0800	<input checked="" type="checkbox"/> 0800-1400	BB	MM	CH	PR	<input type="checkbox"/> 0200-0800	<input checked="" type="checkbox"/> 0800-1400
9	3	9	9	<input type="checkbox"/> 1400-2000	<input type="checkbox"/> 2000-0200	9	3	9	9	<input type="checkbox"/> 1400-2000	<input type="checkbox"/> 2000-0200

MONTH 2: December

WEEKEND				TIME PERIOD		WEEKDAY				TIME PERIOD	
BB	MM	CH	PR	<input type="checkbox"/> 0200-0800	<input checked="" type="checkbox"/> 0800-1400	BB	MM	CH	PR	<input type="checkbox"/> 0200-0800	<input checked="" type="checkbox"/> 0800-1400
9	9	9	9	<input type="checkbox"/> 1400-2000	<input type="checkbox"/> 2000-0200	9	9	9	9	<input type="checkbox"/> 1400-2000	<input type="checkbox"/> 2000-0200

COMMENTS: Pier open 24 hours from April 1 through  
September 30. October and November hours 8 am  
to 4 pm, closed completely in December, January,  
and February. March hours 6 am to 6 pm

No parking fee but \$5 fee to fish.

## Chapter 2. Intercept Survey Definitions

**Figure 2.4: Site Description Form — Deactivating a Site**

1 2 3 4 1<sup>ST</sup> INTERVIEWER    2010 SITE DESCRIPTION FORM    STATE 3 7

2<sup>ND</sup> INTERVIEWER    COUNTY 0 5 5

2 0 1 0 0 3 0 9 YYYY MM DD    SITE 3 4 5 6

WEATHER CONDITIONS (ONE PER COLUMN)	<input type="checkbox"/> CLEAR	<input type="checkbox"/> NO WIND (0 KNOTS)	<input type="checkbox"/> NO PRECIPITATION
	<input type="checkbox"/> PARTLY CLOUDY	<input type="checkbox"/> BREEZY (1- 16 KNOTS)	<input type="checkbox"/> RAIN
	<input type="checkbox"/> CLOUDY	<input type="checkbox"/> WINDY (17-33 KNOTS)	<input type="checkbox"/> SNOW
	<input type="checkbox"/> STRONG WIND (34+ KNOTS)	<input type="checkbox"/> MIX	

LATITUDE N 3 5 : 5 0 : 1 7 . 2

LONGITUDE W 7 5 : 4 7 : 3 3 . 7

NEW SITE

SITE NAME Salty Fish Marina

STREET ADDRESS Springville Rd

CITY Currituck    STATE NC    ZIP 1 2 3 4 5

CONTACT NAME \_\_\_\_\_ PHONE 9 1 9 5 5 5 3 3 3 3

DIRECTIONS FROM MAJOR HIGHWAY Marina went out of business  
last month (condos are being planned  
for the site)

### MODES PRESENT/SITE ATTRIBUTES

	YES	NO	CANNOT DETERMINE		YES	NO	CANNOT DETERMINE		YES	NO	CANNOT DETERMINE
MAN-MADE	<input type="checkbox"/>	<input checked="" type="checkbox"/>	<input type="checkbox"/>	NIGHT FISHING MM?	<input type="checkbox"/>	<input checked="" type="checkbox"/>	<input type="checkbox"/>	PRIVATE ACCESS?	<input type="checkbox"/>	<input checked="" type="checkbox"/>	<input type="checkbox"/>
BEACH/BANK	<input type="checkbox"/>	<input checked="" type="checkbox"/>	<input type="checkbox"/>	NIGHT FISHING PR?	<input type="checkbox"/>	<input checked="" type="checkbox"/>	<input type="checkbox"/>	CAN WE INTERVIEW?	<input type="checkbox"/>	<input checked="" type="checkbox"/>	<input type="checkbox"/>
HEAD BOAT	<input type="checkbox"/>	<input checked="" type="checkbox"/>	<input type="checkbox"/>	NIGHT FISHING CH?	<input type="checkbox"/>	<input checked="" type="checkbox"/>	<input type="checkbox"/>	FISHING PRESSURE AFFECTED BY TIDE?	<input type="checkbox"/>	<input checked="" type="checkbox"/>	<input type="checkbox"/>
CHARTER BOAT	<input type="checkbox"/>	<input checked="" type="checkbox"/>	<input type="checkbox"/>	ADEQUATE LIGHTING?	<input type="checkbox"/>	<input checked="" type="checkbox"/>	<input type="checkbox"/>	# HB USING SITE	<input type="text" value="00"/>		
PRIVATE/RENTAL BOAT	<input type="checkbox"/>	<input checked="" type="checkbox"/>	<input type="checkbox"/>	SAFE AT NIGHT?	<input type="checkbox"/>	<input checked="" type="checkbox"/>	<input type="checkbox"/>	# CH USING SITE	<input type="text" value="00"/>		
NIGHT FISHING BB?	<input type="checkbox"/>	<input checked="" type="checkbox"/>	<input type="checkbox"/>	COMMERCIAL FEE FOR USE OF SITE? (EX: ENTRANCE/LAUNCHING/ PARKING FEE.)	<input type="checkbox"/>	<input checked="" type="checkbox"/>	<input type="checkbox"/>				

### Hostile Sites

The term "**hostile site**" indicates any site where site management does not permit interviewers to interview anglers. Hostile sites are not assigned.

If an interviewer visits a site and finds that interviewers are no longer allowed to interview there, the site should be considered "HOSTILE." The interviewer should provide a detailed explanation as to why he/she feels the site is hostile. In addition, the interviewer should notify project staff immediately to inform him/her that the site is now hostile.

### Dealing with Hostility

As a field interviewer working with the public, you may encounter some hostility, either from the anglers you're interviewing or from the general public. To that end, NOAA Fisheries and DMF are offering some general guidelines as to what to do (and what not to do) when you encounter hostility.

Here are some points to remember when dealing with hostility:

- A hostile attitude sometimes is just the result of somebody having a bad day.
- Remember that moods are catchy – if you show up expecting hostility then you just might get it.
- Be aware of your body language, and pay attention to that of others.
- Approach with a smile, and use a simple, friendly ice-breaking comment, such as "How was fishing today?" or "How was the weather out there?"
- If you encounter hostility, try not to take it personally.
- If anyone tries to make it personal, be able to deflect it. For example, if someone lumps you into the category of "you people" you might shrug and say you're just doing your job of interviewing anglers.
- Don't let yourself get dragged into any heated discussions.
- Just listen. Some people just want to vent, and they will eventually "cool down".
- Sympathize without being in agreement. For example, you might say something to the effect of "I can see how that might make you frustrated".
- Don't be accusatory or defensive.
- Be able to modify your response to fit the situation. It is OK to say something like "I can see that you're really angry right now and I'm sorry you're having a bad day, so I'll come back another time; hope your day gets better".
- Never tolerate foul language (say "have a nice day" and immediately walk away).
- Resist the urge to use foul language when faced with a confrontational situation. This just makes the situation worse.
- If anyone threatens bodily harm, leave the premises immediately and provide documentation to DMF.
- Always be on your best behavior – you never know who you're interviewing, or who's watching you from a distance.

### CHAPTER 3. ASSIGNMENT DISTRIBUTION

#### The Assignment

A beach/bank (BB), man-made(MM), private boat (PR), or charter boat (CH) "assignment" consists of a target mode, a time interval (2am-8am, 8am-2pm, 2pm-8pm, 8pm-2am), a cluster of fishing sites with activity in that target mode, the order in which those sites are to be visited, and the date on which the cluster is to be visited.

Each assignment is assigned a code that refers to the mode of that assignment. Remember that these codes are different from the code used for a fishing mode (see previous chapter for fishing mode codes). Beach/bank assignments (BB) =1, man-made (MM) = 4, private/rental (PR) = 3, and charter boat (CH) = 5.

Refer to pages 5 and 30 for more information about mode of assignment.

DMF is required to complete a fixed number of assignments in each state subregion (North, Central, South) and mode in each wave. These goals are provided by NOAA Fisheries each wave. NOAA Fisheries communicates these assignment goals to project staff at the beginning of each wave, and the expectation is that all goals will be met.

#### How Assignments are Generated and Distributed

A computer program is used to randomly generate the required number of assignments and the days on which they fall.

Interviewers are asked to provide any time-off requests for the following month 10 days before the end of the month. For example: Time-off requests for February are due on January 21<sup>st</sup>. DMF expects that, with few exceptions, interviewers will be available to accept assignments on all other days. It is your responsibility as an interviewer to inform your project staff immediately if you have to make any unexpected changes to your availability.

**Note:** If you work on a charter or a head boat as a captain or a mate, you must inform project staff. Interviewers who work as captains or mates are not allowed under any circumstances to obtain interviews from any charter or head boats in their region. This is a conflict of interest. DMF will not issue you charter or head boat assignments in the county where you do this work, so as to avoid any conflict of interest. You will be issued assignments in BB, MM, and PR modes only.

Once the assignments have been generated and interviewer availability has been received, DMF begins the process of issuing assignments to its interviewers. Project staff match each assignment with an interviewer, giving preference to those interviewers who demonstrate the highest level of competence in all of the procedural and administrative aspects of their position. Approximately one week prior to the start of each month, each interviewer will be sent his/her assignment schedule for the month. Interviewers should contact project staff if they have not received their assignment schedule three days prior to the beginning of a wave.

## Chapter 3. Assignment Distribution

---

### Responsibilities for Assignment Confirmation and Completion

Upon receipt of the assignment schedule, review each assignment carefully to ensure that you are able to complete all assignments on the assigned days. Interviewers must call project staff immediately to discuss any scheduling conflicts. Unless notified otherwise, DMF will assume that all interviewers will be conducting their assignments as distributed.

DMF recognizes that there may be times when an interviewer is unable to perform an assignment on the assigned day. **However, DMF expects this to happen infrequently.** On certain days, it may appear that the weather is not conducive to fishing. **Keep in mind that many people fish in less-than-ideal weather, and interviewers are expected to attempt an assignment on the day it is assigned unless the weather is considered severe (such as a hurricane, extremely high seas, etc.).** Please talk to project staff if you have any questions about the types of weather conditions this includes. Assignments must be completed on the day and time interval they are scheduled. **Rescheduling assignments is not permitted.** An assignment that cannot be conducted due to extreme weather ("weathered-out") is considered a completed assignment with zero intercepts. Please complete the ASF form as you would an assignment with no intercepts. You cannot claim 8 hours for an assignment you were not able to complete.

In very rare situations, other factors may prevent an interviewer from completing an assignment on the assigned day. In this case, interviewers should contact project staff as soon as possible, but no later than two days prior to the assigned day, so that the assignment may be issued to another interviewer. Assignments must be completed on the day and time interval they are scheduled. **Rescheduling assignments is not permitted.**

After assignments have been completed, the interviewer must mail the completed paperwork to DMF by the following Monday. Please keep in mind that even an assignment with no intercept interviews obtained is considered to be "completed." It is equally important that the paperwork for these assignments is mailed to DMF on-time. All data for a given month must be received in the Washington Regional office no later than the third of the following month. This is required to give DMF time to process and review all collected data before delivering it to NOAA Fisheries. DMF keeps track of the date of receipt for each assignment, and this information is incorporated into each interviewer's performance evaluation. **Repeated failure to return completed assignments on-time is sufficient grounds for termination. Your pay may be withheld for assignments received in the Washington Regional office later than the third of the month.**

It is equally important that interviewers submit their Weekly-Tally Sheets on a weekly basis with their paperwork (Saturday through Friday). Incomplete weekly-tallies may result in a failure to meet the required goals. For this reason, even an assignment in which zero intercepts were obtained must be reported (and sent in, along with any SDFs).



### **Chapter 3. Assignment Distribution**

---

Please keep in mind that this information is reported to NOAA Fisheries every week and is used to monitor performance. Repeated failure to report the outcome of all of your assignments on-time is sufficient grounds for termination.

# **CHAPTER 4. DATA COLLECTION PROCEDURES FOR BB, MM, PR, AND CH MODES**

## **Assignment Goals**

For each assignment, the primary goal is to obtain good interviews and accurate counts of anglers in the assigned mode. Key questions that must be completed are marked with an asterisk (\*) on the Intercept Form. These include:

- ✓ Fishing mode;
- ✓ Water fished;
- ✓ Three mile limit for ocean fishing;
- ✓ State and county of residence;
- ✓ All questions related to the fish caught and the anglers who contributed to the catch; and
- ✓ The total number of anglers on the boat

## **Advance Work**

Each assignment specifies an assigned mode (BB, MM, PR, or CH), county, starting site, the cluster ID, the order in which sites are to be visited, time interval, and date. This should be done with the understanding that an assignment lasts six hours, and that anglers must be interviewed at the completion of their fishing trips. You should plan on being at the first site at the time the assignment begins. For example: If your assignment is scheduled 0800-1400 you should be on site at 0800.

You **must** start at your first site, obtain interviews in the assigned mode, and move to the next site after two hours have passed.

## **Arrival at the Site**

Upon arriving at the site, first check in with the person in-charge. Many sites will have no such person, but privately-owned or closely supervised public operations will have a manager in-charge. Both for permission and as a courtesy, you should introduce yourself and summarize the purpose of the survey. Copies of a letter from NOAA Fisheries, shown in Figure 4.1, should be provided to substantiate the legitimacy of the survey and encourage cooperation.

NOTE: The importance of these letters cannot be stressed enough. They are a direct link from NOAA Fisheries to the anglers and should be distributed freely. All business facilities, privately-owned, or monitored public facilities should be given copies for their files. You should always have some copies available when on assignment.

## Chapter 4. Data Collection Procedures for SH, PR and CH Modes

---

**Figure 4.1: To Whom Letter**



UNITED STATES DEPARTMENT OF COMMERCE  
NATIONAL OCEANIC AND ATMOSPHERIC ADMINISTRATION  
NATIONAL MARINE FISHERIES SERVICE  
SILVER SPRING, MARYLAND 20910

**TO WHOM THIS CONCERNS:**

The National Marine Fisheries Service, Department of Commerce, in Silver Spring, MD, is given responsibility under the Fisheries Conservation and Management Act of 1976 for managing the nation's marine resources. This responsibility requires that information be gathered from U.S. recreational anglers pertinent to their marine fishing activities.

Interviewers are being assigned to selected fishing locations along coastal areas of the country in order to talk with marine anglers, and to count and measure their catch. Information collected by interviewers will be analyzed and used to help improve the quality of fishing for all anglers.

You are encouraged to cooperate with the interviewer at your location; however, participation is voluntary. Questions regarding the surveyor activities of the interviewer may be addressed to:

Dave Van Voorhees, Ph.D.  
Division Chief  
Marine Recreational Fisheries Statistics Program  
U.S. Department of Commerce  
National Oceanic and Atmospheric Administration  
National Marine Fisheries Service  
1315 East-West Highway, Room 12362  
Silver Spring, Maryland 20910  
(301) 713-2328

The Survey is described in detail and actual survey data are available at our web site:  
<http://www.st.nmfs.gov/st1/index.html>. Go to the Fisheries Statistics and Economics Division and then to the Recreational Fisheries section.

The public reporting burden for the Intercept Survey portion of the Marine Recreational Fishery Statistics Survey (OMB No. 0648-0052) is estimated to average 4.5 minutes per interview, including the time for reviewing instructions, searching existing data sources, gathering and maintaining the data needed, and completing and reviewing the collection of information. Send comments concerning this burden estimate, including suggestions for reducing this burden, to the office listed above and/or to the:

Office of Management and Budget  
Paperwork Reduction Project (0648-0052)  
Washington, D.C. 20503



## Chapter 4. Data Collection Procedures for SH, PR and CH Modes

---

### Equipment Checklist

Prior to beginning your assignment, you should use the following equipment checklist to make sure that you have all the necessary equipment and paperwork. If you are in need of any of the following, please contact project staff, and more will be sent to you.

- ✓ 1 ASF (green form)
- ✓ At least 100 Intercept forms
- ✓ 3 To Whom Letters
- ✓ 3 Privacy Act Letters
- ✓ 1 Site Register
- ✓ 3 Site Description forms
- ✓ Good Vessel List
- ✓ 1 Peterson's field guide
- ✓ Scales—two sizes
- ✓ Measuring Board and Tape Measure
- ✓ Pencils
- ✓ Name Badge
- ✓ DMF hat
- ✓ Time piece (watch, cell phone)
- ✓ Coding Manual
- ✓ Procedures Manual
- ✓ GPS unit, if applicable

### Visiting Your Assigned Site

You must visit your assigned sites on the assigned day during the assigned time interval. Intervals are coded on the Assignment Summary Form and schedule as follows.

Interval 1=0200-0800  
Interval 2=0800-1400  
Interval 3=1400-2000  
Interval 4=2000-0200

You must **always** visit your sites **IN THE ORDER IN WHICH THEY ARE ASSIGNED**. There are only two exceptions to this rule:

1. **You are unable to locate your assigned site.** There may be occasions when you will be unable to locate the assigned site, and unable to reach project staff for assistance in locating the site. When this happens, move to the second assigned site. When this happens and the first site is not visited, make note of this on the “comments” section of the Assignment Summary Form (ASF). You must contact project staff afterwards to attempt to locate the site and include better descriptive information in the Site Register.
2. **The assigned site is closed.** Some sites close at certain hours (e.g. dusk), times of the year (e.g. Thanksgiving through April), or for repairs. When this happens,

## Chapter 4. Data Collection Procedures for SH, PR and CH Modes

---

move to your next assigned site and record the appropriate code for leaving the previous site on your ASF. You are not required to return to this site during the time it is closed on this or any later assignments until the site reopens.

You should NOT leave your *assigned site* if you encounter another interviewer at your assigned site. Unless an error was made during scheduling, you will be the only MRIP interviewer assigned to that site on that day. If you encounter another MRIP interviewer in the field please contact project staff. If you encounter a MRFSS, CSMA (Central and Southern Management Area), or other survey staff you may continue to work the site. You should coordinate sampling with the other survey interviewer in order to prevent duplicating effort. Be sure that all questions unique to each survey are answered accordingly and that proper procedures are followed for interviewing and taking fish measurements. Please record the site number of the encounter on the ASF. **If you do not visit one of your assigned sites, please make sure to record the appropriate reason code on your ASF.**

Editing time is not allowed for assignments with zero intercepts.

Please keep in mind that you need to number the intercept forms consecutively, starting with "01" for the first interview on an assignment, regardless of where this interview was completed. E.g.: if you interview three people at your first site, they will be numbered as intercepts 01, 02, and 03. If you then go to your second site and interview two more anglers, those intercepts must be numbered 04 and 05. If you go to your third site and interview four additional anglers there, those intercepts would be numbered 06, 07, 08 and 09. Remember to record the proper site number for all intercepts!

### Cluster Sampling

The Pilot Study differs from the MRFSS in that in the Pilot Study all sites to be visited on an assignment are pre-selected (i.e. clustered); the MRFSS allows the interviewer to select alternate sites. Sites are clustered based on time interval, pressure, and geographic proximity. Sites more than one hour drive-time from one another cannot be clustered together. Clusters may have between one and three sites. You should plan on being at the first site at the time the assignment begins. For example: If your assignment is scheduled 0800-1400 you should be on site at 0800. **You must visit your sites in the order they are assigned.** Note that if you arrive late at the first site, you cannot stay late to "make up" for it.

#### Three Site Clusters

You must spend two hours on-site at your first and second site. Once you arrive at the third site you must stay until the end of the six-hour time interval, even if you have not been at that site for the full two hours. For example: Your assignment is scheduled for interval 1 (0200-0800). You must arrive at site 1 at 0200 and leave at 0400. You then arrive at site 2 at 0415, therefore you must leave at 0615. You then arrive at site 3 at 0630, therefore you must leave at 0800 even though you have only been conducting sampling for one hour and thirty minutes.

## **Chapter 4. Data Collection Procedures for SH, PR and CH Modes**

---

### **Two Site Clusters**

You must spend two hours on-site at your first and second site. After you finish your two hours at the second site you must circle back to the first site and stay until the end of the six-hour time interval, even if you have not been at the site for another two hours. For example: Your assignment is scheduled for interval 1 (0200-0800). You must arrive at site 1 at 0200 and leave at 0400. You then arrive at site 2 at 0415, therefore you must leave at 0615. You then go back to site 1, arriving at 0630. Therefore you must leave at 0800 even though you have only been conducting sampling for one hour and thirty minutes.

### **Single Site Clusters**

This is the only cluster where you will stay at one site for the entire six-hour time interval. For example: Your assignment is scheduled for interval 1 (0200-0800). You must arrive at site 1 at 0200 and leave at 0800.

### **Site Closings**

There will be times when a site is closed for various reasons. If you visit a site that is closed you should record the time spent at the site on the ASF along with the appropriate reason code for leaving. If the cluster is a single site cluster the assignment should be considered completed. If the cluster is a two site cluster proceed to the next or, if the second site is the closed site, return to the previous site and complete your sampling time interval at that site. If the cluster is a three site cluster proceed to the next or, if the third site is the closed site, return to the first site and continue sampling as if the cluster were only two sites.

### **Conducting Counts**

Some of your time spent sampling will be dedicated to counting the number of people fishing instead of conducting interviews. At sites with low activity you should be able to both count and conduct interviews at the same time. At sites with moderate-to-high activity you will alternate between counting and conducting interviews by the hour. Be sure to record the start and stop time for the time spent counting and the time spent interviewing as two separate sampling periods, even if you do not switch sites. When conducting counts you will be asked to specify the number of confirmed trips and unconfirmed trips. This refers to whether or not you had the opportunity to ask whether the person(s) were fishing on the day of the assignment. If someone replies that they were in fact fishing this is a confirmed trip. If you do not have the opportunity to ask (for ex: you're conducting an interview, but you saw someone leaving the site carrying a fishing pole) then that is an unconfirmed trip. If someone informs you they were not fishing on the day of the assignment you do not include them in your counts.

### **Mode-Specific Procedures for BB, MM, PR, and CH Assignments**

You are not allowed to conduct interviews with persons who have only partially completed their fishing trip. All persons interviewed must be done fishing for the day. The on-site procedures differ slightly for each mode of fishing. The following subsections describe the typical procedures for each mode.

#### **Beach/bank (BB): Assignment Mode 1**

When a **beach** or **bank** site is assigned, you will typically have to cover a stretch of coastline with anglers scattered along the area. If there is a predominant exit point from the site (e.g., a central parking facility), position yourself there. If no such point exists, stand in an area where the majority of anglers are within sight and easily accessible. Close observation of the fishing activity is required since you must be alert to anglers leaving the site.

If no suitable observation spot can be found, your effort should be concentrated on the stretches where the most anglers are present.

#### **Man-made (MM): Assignment Mode 4**

If you are assigned to a site with fishing at a **pier, jetty, or bridge**, you should be stationed at a point of access (entry-exit) to the site. The station should be such that all anglers leaving the site can be easily seen and approached. Your position should not be next to a fish cleaning stand, since only anglers with fish will stop at the stand; this will bias the sample towards anglers with catch.

#### **Private and Rental Boats (PR): Assignment Mode 3**

Since there are key differences between the various boat landing/docking facilities, the best approach for a particular site must be determined by the interviewer. For private boat interviews, the anglers may be interviewed while waiting for a boat hoist or while cleaning the boat at the dock. Others may be interviewed in the parking lot while waiting for access to a ramp to remove the boat from the water. You will have to use discretion in determining the best approach.

Keep in mind that canoes and kayaks are two specific types of boats that recreational anglers will fish from. We want to approach these people also and administer the screening questionnaire to them to see if they are eligible for the survey.

As with any mode, you should never position yourself next to a fish cleaning stand. As mentioned earlier, only anglers who caught fish will stop at the stand, and the sample will be biased towards anglers with catch. Anglers without catch should be given the same priority as those with catch.

NOTE: If you are unable to interview all anglers on all boats, it is better to interview one angler from each boat than every angler on one boat!

## **Chapter 4. Data Collection Procedures for SH, PR and CH Modes**

---

### **Charter Boats (CH): Assignment Mode 5**

You should never go out on a charter boat. Intercept procedures for charter boats resemble those for private and rental boats (described above). With charter boat sites, however, it is well worth the effort to call the site or charter boat captains in advance to find out the boats' schedules. **If no charter boat trips are scheduled at any of the sites within a cluster you must consider the assignment complete.**

You should strive to complete individual interviews and catch records for each member of the charter group. However, this may be difficult for charter boats since anglers often have little control over the handling of their fish, which are often stored together. **Under no circumstances can interviews be conducted with charter captains or mates.** They are not considered "recreational anglers" even though they may have fished. Captains and mates may only be consulted to determine the actual water area fished. **Any fish caught by the captain or mate should be included in your counts as Type 3 fish where applicable, but do not include the captain or mate as contributors.**

### **Tournaments**

For the purposes of this survey, a tournament is defined as a fishing contest lasting seven or fewer days for which participants have to register. Prizes are given according to the rules of the contest. Informal "pools," such as those arranged on head boats, are not considered tournaments.

Tournaments are INCLUDED in this survey. You should document on the ASF that the site was a tournament "Weigh Station".



# CHAPTER 5. INTRODUCING THE INTERCEPT SURVEY

## Eligibility Requirements

To be eligible for an interview, an angler must:

- ✓ Be a saltwater recreational angler who intended to catch finfish, or a shellfisher who has incidentally caught finfish;
- ✓ Have completed his/her fishing trip, defined as one waking day of fishing in one mode; and
- ✓ Have fished in U.S. waters.

### Determination of a Recreational Angler

For this survey, a recreational fishing trip is one that is taken for fun or relaxation as opposed to one taken to provide income from the sale of fish. The trip's purpose at the beginning of the day defines the trip. Anglers who sell their catch to cover the expense of their fishing trips are not necessarily fishing to provide income; these anglers are eligible. If a commercial fisher has an unproductive fishing day, he or she may think about changing the trip's purpose from commercial to recreational—but if the fisher started the trip with the purpose of providing income from the sale of fish, he or she is not a recreational angler and should not be interviewed.

### Determination of Saltwater

Only known saltwater fishing sites are included in the Site Register, and all assignments are generated based on these registers. As a result, most of the anglers encountered will be saltwater anglers. **In estuarine areas, however, the definition of saltwater is often difficult. Inland saltwater bodies include sounds, passes, inlets, bays, estuaries, and other areas of salt or brackish water like bayous and canals. Some coastal water bodies are called lakes, but should still be considered saltwater. However, high-salinity, non-coastal lakes (like Lake Pontchartrain in Louisiana) are not valid marine recreational fishing areas.** At sites where both freshwater and saltwater fishing occur, you must ask each angler whether he or she was freshwater or saltwater fishing. Anglers who say they were freshwater fishing are not eligible for the survey and should not be interviewed. Note that we do not include freshwater anglers (anglers targeting freshwater fish) who may have incidentally caught a saltwater fish.

**PLEASE NOTE:** If you know the angler was NOT fishing in saltwater, even if the angler says she/he did, terminate the interview (ineligible) and move on.

### Targeting Finfish or Incidental Catch by Shellfishers

The angler's actual catch has no effect on eligibility. If an angler has thrown fish back, or did not catch anything at all, he or she is still eligible for an interview as long as there was an *intent* to catch finfish. There is a screening questionnaire (see below) that should be administered to each angler to determine if he or she can participate in the survey. Respondents pursuing crabs, shrimp, lobster, clams, squid, oysters, and other

## Chapter 5. Introducing the Intercept Survey

---

invertebrates are not eligible for the survey unless they incidentally caught a finfish during their fishing trip. Regardless of whether or not the finfish was kept, this angler is eligible for the survey and should be interviewed.

### Determination of a Completed Trip

You will only be interviewing anglers who have completed their fishing trips. A trip is considered complete if an angler has finished fishing in that mode for the day. If an angler is moving from one site to another site in the same mode (e.g., from a dock to a bridge), that angler has not completed the trip and is not eligible for an interview. If an angler is moving from one mode to another mode (e.g., from a dock to a boat) at either the same site or different sites, that angler has completed a trip and is eligible to be interviewed about the trip he or she has just completed. If an intercepted angler has completed two trips, having fished in two different modes, then ask questions pertaining only to the most recently finished trip.

A one-day trip refers to the angler's waking day, as opposed to a calendar day. A trip beginning in the evening, but ending past midnight, is considered one trip. When you intercept an angler who has been on a trip lasting several days, most likely a boat trip, each of the angler's waking days is considered a separate trip. Conduct the interview only about the *most recent waking day of fishing*. In other words, if the angler's waking day was more than 24 hours, **only** the most recent 24 hours should be considered.

### Canvassing Introduction

At some sites, it is possible to build a rapport with the people fishing prior to conducting any interviews. Anglers who have had the opportunity to meet you and discuss the survey tend to be more cooperative when it comes time to ask for an interview at the end of a fishing trip. Assuring the respondent that you are not part of any enforcement effort and informing him or her about the survey's basic research nature is important for gaining the respondent's initial cooperation and trust in the study.

### Screening Introduction

The Screening Introduction (shown in Figure 5.1 on the following page) serves two major purposes:

- ✓ To introduce the interviewer and the survey; and
- ✓ To determine if the angler is eligible for an interview.

While you will be given several copies of the Screening Introduction, you should not need it on a routine basis if you fully understand the study background and eligibility requirements. When you approach an angler, introduce yourself and tell him or her that the study you are conducting is sponsored by NOAA Fisheries. At no time should you claim to be an employee of NOAA Fisheries. If the angler is willing to cooperate, then you would ask the eligibility questions.

## Chapter 5. Introducing the Intercept Survey

---

### Figure 5.1: Survey Introduction and Eligibility Determination

#### SURVEY INTRODUCTION & DETERMINATION OF ELIGIBILITY

To be eligible for an interview, an angler must:

- ✓ Be a saltwater recreational angler who intended to catch finfish, or a shellfisher who has incidentally caught finfish;
  - ✓ Have completed his/her fishing trip, defined as one waking day of fishing in one mode;
  - ✓ Have fished in U.S. waters [If not, code as "Not US" on ASF].
- 

Hello, my name is \_\_\_\_\_ and I represent NCDMF. We are interviewing marine recreational anglers for a study sponsored by the National Marine Fisheries Service of the U.S. Department of Commerce. I'd like to ask you a few questions about your fishing.

Was the primary purpose of your trip today for recreation, that is, for fun and relaxation, or was it to provide income either from the sale of fish or from the sale of the fishing opportunity?

Recreation	————→	Continue
To provide income	————→	End interview, angler not eligible [Code as "Not Rec" on ASF]

**Item 1** This question determines whether the angler meets the recreational criteria. A "to provide income" response will end the screening because the respondent is not a recreational angler. A "recreational" response to Item 1 will lead to Item 2. You must ask about the trip just completed, regardless of the type of fishing license possessed.

Were you saltwater fishing today? By saltwater fishing, I mean fishing in oceans, sounds or bays, or in brackish portions of rivers.

Yes	————→	Continue
No	————→	End interview, angler not eligible [Code as "Not Salt" on ASF]

**Item 2** This question verifies that the angler is a saltwater angler. A "no" response to Item 2 will end the screening. A "yes" response will lead to Item 3. Use your knowledge of the area when screening for this question. For example, if an angler indicates that he/she was fishing in saltwater, but you know that it has been raining heavily, making the fished area actually freshwater because the salt wedge has moved downstream, you should terminate the interview.

Were you fishing for finfish today?

Yes	————→	Continue with question 4
-----	-------	--------------------------

## Chapter 5. Introducing the Intercept Survey

---

No                                      —————> Continue with question 3a

**Item 3** This question verifies that the person is targeting finfish. That is, his/her fishing trip was directed at fish with fins. A "yes" response to Item 3 will lead to Item 4. Note that an angler does not have to have *caught* any finfish, as long as he/she was *fishing for finfish*. A "no" response to Item 3 will lead to Item 3a.

3a. Did you catch any finfish today?

Yes                                      —————> Continue  
No                                        —————> End interview, angler not eligible [Code as "Not Fin" on ASF]

**Item 3a** This item identifies shellfishers who caught one or more finfish. A "no" here means that the angler is not eligible for the survey. A "yes" will lead to Item 4.

Have you completed your saltwater fishing today?

Yes                                      —————> Angler is eligible, start main Atlantic Intercept Survey questionnaire  
No                                        —————> Continue

**Item 4** All marine recreational anglers who intended to catch finfish are asked whether they have completed their fishing for the day. If the response is "yes," the angler is eligible for the survey and you should start the main Intercept Questionnaire at this point. If the response is "no," you will continue by asking Item 5.

Will you still be fishing from a (SPECIFY MODE)?

Same mode                            —————> End interview, angler not eligible [Code as "Not Done" on ASF]  
Different mode                      —————> Angler is eligible, start main Atlantic Intercept Survey questionnaire

**Item 5** Anglers who are coming back to the same site to fish are eligible **ONLY** if they plan to fish from a different mode when they return. They are not eligible if they are planning to fish from the same mode at the same site later in the day.

Similarly, anglers who are going somewhere else to fish are eligible **ONLY** if they plan to fish from a different mode at their next site. They are not eligible if they are planning to fish from the same mode at a different site later in the day.

### Privacy Act Statement

As soon as the angler's eligibility is established, you must read the Privacy Act statement. An abbreviated version of this statement appears on the Intercept Form just above Item 11. While this rather short statement will be read to all anglers, you will be given — and must carry — several copies of a longer Privacy Act Statement. These copies should be handed out to anglers who want more information. You are legally required to always have at least one copy of the Privacy Act available to anglers at all times. (Please call DMF staff if you need more copies, or make photocopies of the one that is in this manual—never hand out your last copy. An example of the Privacy Act Statement is in Figure 5.2.

#### Figure 5.2: Privacy Act Statement

### Privacy Act Statement

All surveys conducted by the Federal Government are regulated by the Privacy Act of 1974. This Act stipulates that each person interviewed must be informed of the following: (1) The auspices under which the survey is being conducted; (2) That participation is voluntary; and (3) How the information will be used. The Privacy Act also stipulates that this information must be available to each survey respondent in written form. While this information is outlined on the handout, most anglers are satisfied after hearing the abbreviated statement. The Privacy Act Statement reads as follows:

#### PRIVACY ACT STATEMENT

Information collected in the Marine Recreational Fisheries Statistics Survey is authorized under the Fish and Wildlife Act of 1956, the Migratory Marine Fish Act of 1959, and the Fishery Conservation and Management Act of 1976. This information will be used in assessing the influence of fishing on any fish stock and in determining future recreational fishing needs.

All information collected will be combined with information provided by other recreational anglers and used only for statistical purposes. Any information which would permit identification of the individual will be held in strictest confidence and will be used only by persons engaged in and for the purpose of the survey.

Participation in this survey is voluntary and there are no penalties for refusing to answer any question. However, your cooperation in obtaining this much needed information is extremely important in order to insure the completeness and accuracy of the statistical results.

## Chapter 6. Assignment Summary Form

---

### CHAPTER 6. ASSIGNMENT SUMMARY FORM

#### Assignment Summary Form

An Assignment Summary Form (ASF) must be completed for *every assignment* whether or not interviews are obtained. An example of an ASF form is included in *Appendix A*. The ASF includes the following:

**NAME** – Print and sign your name in the rectangular box provided at the top of the page.

#### 2010 MRIP ASSIGNMENT SUMMARY FORM

NAME:
SIGNATURE:

**INTERVIEWER ID NUMBER** – Enter your four-digit identification code number. If two interviewers are working the assignment (e.g. nighttime assignments) be sure to include both interviewer numbers.

				1 <sup>ST</sup> INTERVIEWER
				2 <sup>ND</sup> INTERVIEWER

**YR/MO/DD COMPLETED** – The current year will be hard-coded on the form. You should enter a two-digit number for the month, followed by a two-digit number for the day of the month when you completed the assignment. **Do not use any forms with a date other than “2010”** – forms may look similar, but changes may have been made. All forms from previous years should be discarded.

2	0	1	0					YYYY MM DD
	MODE: 1=BB, 3=PR, 4=MM, 5=CH					STATE		
			COUNTY					
					CONTROL NUMBER			

**MODE** – Enter the appropriate one-digit number for the **ASSIGNED** mode. Use “1” for BB mode, “3” for PR mode, “4” for MM mode, and “5” for CH mode. Switching modes is absolutely prohibited.

**STATE** – Enter the two-digit state code for the state where the assignment was completed.

## Chapter 6. Assignment Summary Form

---

**COUNTY** – Enter the three-digit county code for the county where the assignment was completed.

**CONTROL NUMBER** – Enter the appropriate five-digit control number for the assignment. This number is provided on the list of assignments that you receive from DMF

**EDITING HOURS** – Enter the total editing hours for the assignment. Remember the five-minute-per-interview guideline. If you have no editing time to claim, please fill in the boxes with zeros. You will not be paid for editing time if you did not obtain any intercepts. Also, make sure that this is a true reflection of how much time was spent editing the paperwork for that particular assignment. Only include time spent editing outside of the assignment. For example, if you spent two hours on site and obtained three interviews, you are expected to edit those forms while at the site. Similarly, if you were on site for two hours but obtained 23 interviews, it would be reasonable to expect you to need time outside of the assignment to edit.

●  **EDITING HOURS (ROUND TO THE NEAREST 0.25 HR)**

**ASSIGNMENT TIME INTERVAL** – Enter the time interval for the scheduled assignment. You cannot reschedule assignments for different time intervals.

**ENCOUNTERED ANOTHER INTERVIEWER** – Indicate whether you encountered another interviewer (either MRIP or from another survey). If you encounter another interviewer please list the site number.

**ASSIGNMENT INTERVAL: 1=0200-0800, 2=0800-1400, 3=1400-2000, 4=2000-0200**  
 **ENCOUNTERED ANOTHER INTERVIEWER: 1=YES, 2=NO IF YES SITE NO: \_\_\_\_\_**

**SUMMARY SECTION** – Please list the cluster ID (four-digit number) associated with sites visited on the assignment. Sites must be visited in the order they are assigned and the summary section should be completed in this order. If you do not visit your sites in order, we cannot use any of the data that was collected. Two additional lines are provided for the second and third sites, if applicable. In the event that a site must be visited twice (see “Site Closings”) there is a fourth line to provide any summary information. Please list the order of that site within the cluster (e.g. 2<sup>nd</sup> site).

## Chapter 6. Assignment Summary Form

---

CLUSTER ID				
	SITE			
1 <sup>ST</sup> SITE				
2 <sup>ND</sup> SITE				
3 <sup>RD</sup> SITE				
___ SITE				

If all your summary responses are zeros, then you must fill out the entire summary section with zeros. Please do not leave anything blank.

**“Weigh Station”** – Please indicate whether the site visited was a tournament weigh station (1=yes, 2=no).

**WEIGH STATION:**  
1=YES, 2=NO

**“Interview Status”** – This section represents the number of interviews obtained, by mode and site, for the assignment.

INTERVIEW STATUS							
1 & 2		3		4		5	

3 = Initial Refusal, 4 = Language Barrier, 5 = Refused Key Item



## Chapter 6. Assignment Summary Form

---

The “Other Status Interviews” section represents the number of status 3 (initial refusal), 4 (language barrier), and 5 (refused key item) anglers encountered.

**“Initial refusal = 3”**—This code should be used if an eligible angler refuses to be interviewed at the outset. Anglers who refuse to be interviewed will usually claim that they do not have time to participate. However, you should always attempt to determine eligibility. If an angler is eligible, but refuses to be interviewed, record this record on the ASF under “Interview Status”. No intercept form is required for that angler. Please keep in mind that under no circumstances should you include pleasure boaters, sunbathers, etc., as Status 3. Please tally appropriately in the “Counts” section.

**“Language barrier, etc. = 4”**—This code should be used if the angler approached for an interview cannot respond to the interview in English and no other person is willing or able to translate. Such anglers include non-English speaking anglers and deaf anglers. Conducting the interview in a language other than English is allowed, as is using an interpreter for the interview. If either of these methods is used, please note it on the form next to the name and phone number. If you are not able to complete the interview with an eligible angler due to a language barrier, record this angler in your Status 4 count on the ASF under “Interview Status”. No intercept form is required for this angler.

As with initial refusals from anglers, you should assume that anglers who you cannot communicate with are eligible unless you have information that indicates that the angler is not eligible. Please note that foreign pleasure boaters, sunbathers, etc., should not be counted in the Status 4 count. Please tally appropriately in the “Counts” section.

**“Refused key item = 5”**—This code should be used if the angler refuses to answer a key item. If a key item is refused, code that item with “9”, thank the angler, and terminate the interview. You should submit all Status 5 Intercept Forms, but do not give them an intercept number (Item 5). Each Status 5 intercept should be recorded on the ASF under “Interview Status”.

**INELIGIBLE ANGLERS** – Anglers that are not eligible for participation in the survey are separated into several categories. These anglers should be counted and recorded in the summary section of the ASF.

- ✓ **“Not Done”** – enter the number of anglers actively fishing at the site in the target mode when you leave the site **each time**. For example, if you are at site A from 8 am to 10 am, then at site B from 10:30 am to 11:00 am, then go back to site A from 11:30 am to 1:30 pm, the summaries for site A will be recorded on two separate lines and represent activity at the site **only** for those specific time periods.

The other “ineligible” categories include those approached but found to be ineligible because of responses to questions in the screening introduction. Please make sure you understand what should, and should not, be included in these categories. Only include anglers who are “probably eligible” for the survey (i.e. those who were fishing, or caught a finfish). Do NOT include sunbathers, swimmers, boaters, etc.

## Chapter 6. Assignment Summary Form

- ✓ “**Not Rec**” = *Not Recreational*: Commercial anglers/anglers whose primary purpose of the trip is to provide income.
- ✓ “**Not Salt**” = *Not Saltwater*: Recreational anglers fishing in freshwater.
- ✓ “**Not Fin**” = *Not Finfishing*: Saltwater recreational anglers who did not target, or catch, finfish. For example, individuals targeting lobsters or other shellfish, who did not catch any finfish during their trip, would be recorded here.

INELIGIBLE											
NOT DONE			NOT REC		NOT SALT		NOT FIN				

**REASON FOR LEAVING SITE CODES** – If you leave your site to visit another site or because your sampling time interval ended please select the appropriate reason for leaving code. If you can’t find the site, you must still include the site in this section.

REASON FOR LEAVING SITE	REASON FOR LEAVING SITE CODES								
<table border="1" style="width: 100%; height: 100%; border-collapse: collapse;"> <tr><td style="width: 50%; height: 30px;"></td><td style="width: 50%; height: 30px;"></td></tr> <tr><td style="width: 50%; height: 30px;"></td><td style="width: 50%; height: 30px;"></td></tr> <tr><td style="width: 50%; height: 30px;"></td><td style="width: 50%; height: 30px;"></td></tr> <tr><td style="width: 50%; height: 30px;"></td><td style="width: 50%; height: 30px;"></td></tr> </table>									06 COULDN'T FIND SITE 07 OTHER INTERVIEWER PRESENT 08 ASKED TO LEAVE 09 OTHER ( <i>SPECIFY IN COMMENTS</i> ) 10 2HR SAMPLING TIME ENDED 11 END OF 6HR SAMPLING TIME 12 SITE CLOSED AFTER HOURS ( <i>TIME IN COMMENTS</i> ) 13 SITE CLOSED OTHER ( <i>SPECIFY IN COMMENTS</i> ) 14 SITE UNSAFE DURING SAMPLE PERIOD

**ON-SITE RECORD** – This section of the form records the “start” and “stop” times for visits to each site during the course of the assignment. You should always identify each site by entering the appropriate code number in the boxes under the “site” heading. List the sites in the order that you visited them, including any return trips to the first assigned site for two site clusters.

**“Survey Method”** – Please indicate whether time was spent conducting interviews (1), counts (2) or both simultaneously(3).

## Chapter 6. Assignment Summary Form

SURVEY METHOD:  
1=INTERVIEW,  
2=COUNT,  
3=BOTH

START TIME	STOP TIME	SITE	

**“Angler Trips”** - Remember you should alternate between interviewing and counting on an hourly basis at sites with moderate-to-high activity so that counts are accurate. “Moderate-to-high activity means situations where multiple anglers leave the site at the same time, causing you to compromise the accuracy of your angler counts. Start and stop times should be recorded for each survey method. Please refer to page 28 for definitions of confirmed and unconfirmed trips. Please tally appropriately in the “Counts” section.

**(COMPLETED)**  
**ANGLER TRIPS**  
*(CONFIRMED BY ANGLER)*

CONFIRMED	UNCONFIRMED

## Chapter 6. Assignment Summary Form

**“Counts”** – Space is provided on the ASF for tallying status 3 and 4 interviews, as well as confirmed and unconfirmed trips at each site. You are required to tally these anglers as well as record the number in the summary sections. Each angler should be represented by a tally mark. Four vertical tally marks crossed with a diagonal mark represents five anglers (see Appendix A for completed forms).

SITE	STATUS 3	STATUS 4	CONFIRMED	UNCONFIRMED
1 <sup>ST</sup>				
2 <sup>ND</sup>				
3 <sup>RD</sup>				

**COMMENTS** – Please use the comments section to communicate additional information about the assignment. Anything unusual or extraordinary should be documented here such as any unusual catches, information you received from industry about fishing conditions or angler sentiment, program brochures given to industry, etc.

**COMMENTS:**

---



---



---



---



---



---



---



---



---



---



---

Example forms are below.

# Chapter 6. Assignment Summary Form

**2010 MRIP ASSIGNMENT SUMMARY FORM**

NAME: Isabel Interviewer  
SIGNATURE: Isabel Interviewer

1<sup>ST</sup> INTERVIEWER: 2345  
2<sup>ND</sup> INTERVIEWER: 1234

DATE: 20100827 YYYY MM DD

MODE: 4 (1=BB, 3=PR, 4=MM, 5=CH) STATE: 37

COUNTY: 055

CONTROL NUMBER: 24015

EDITING HOURS (ROUND TO THE NEAREST 0.25 HR): 0.00

ASSIGNMENT INTERVAL: 4 (1=0200-0800, 2=0800-1400, 3=1400-2000, 4=2000-0200)

ENCOUNTERED ANOTHER INTERVIEWER: 2 (1=YES, 2=NO IF YES SITE NO: \_\_\_\_\_)

SURVEY METHOD: (COMPLETED)  
1=INTERVIEW, 2=COUNT, 3=BOTH  
ANGLER TRIPS (CONFIRMED BY ANGLER)

START TIME	STOP TIME	SITE	3=BOTH	CONFIRMED	UNCONFIRMED
2000	2030	0326	3	00	00
2045	2245	0812	3	00	00
2300	0100	0800	3	00	01
0115	0200	0812	3	00	00
				00	01

COMMENTS:  
326 - some shady characters hanging around so we thought it best to leave  
812 - busier than expected; on return visit the 3 status 5 interviews were too drunk to answer the questions

Do not include intercepted anglers in completed trips section!

SITE	STATUS 3	STATUS 4	CONFIRMED	UNCONFIRMED
1 <sup>ST</sup>	11			
2 <sup>ND</sup>				
3 <sup>RD</sup>		11		1
2 <sup>nd</sup>	1			

← Totals questions

CLUSTER ID	SITE	WEIGH STATION: 1=YES, 2=NO	INTERVIEW STATUS					INELIGIBLE				REASON FOR LEAVING SITE
			1 & 2	3	4	5	NOT DONE	NOT REC	NOT SALT	NOT FIN		
0001	0326	2	00	02	00	00	003	00	00	00	14	
	0812	2	05	00	00	00	002	00	00	00	10	
	0800	2	03	00	02	00	000	00	00	00	10	
	0812	2	02	01	00	03	000	00	00	00	11	
TOTALS			10	03	02	03	005	00	00	00		

REASON FOR LEAVING SITE CODES:  
06 COULDN'T FIND SITE  
07 OTHER INTERVIEWER PRESENT  
08 ASKED TO LEAVE  
09 OTHER (SPECIFY IN COMMENTS)  
10 2HR SAMPLING TIME ENDED  
11 END OF 6HR SAMPLING TIME  
12 SITE CLOSED AFTER HOURS (TIME IN COMMENTS)  
13 SITE CLOSED OTHER (SPECIFY IN COMMENTS)  
14 SITE UNSAFE DURING SAMPLE PERIOD

3 = Initial Refusal, 4 = Language Barrier, 5 = Refused Key Item

# Chapter 6. Assignment Summary Form

**2010 MRIP ASSIGNMENT SUMMARY FORM**

NAME: Alan Angler  
 SIGNATURE: Alan Angler

Do not include intercepted anglers in completed trips section!

SURVEY METHOD: (COMPLETED) ANGLER TRIPS  
 1=INTERVIEW, 2=COUNT, (CONFIRMED BY ANGLER) 3=BOTH

COMMENTS:  
473 - busy site; 5 of the 7 anglers not done showed up around 3:30 pm  
526 - lots of anglers, not catching much though  
473 - still a lot of anglers  
← Totals fishing when I left; catching a few black drum

SITE	START TIME	STOP TIME	SITE	SURVEY METHOD	STATUS	
					CONFIRMED	UNCONFIRMED
1	1400	1600	0473	3	04	02
2	1620	1820	0526	3	02	03
3	1840	2000	0473	3	00	00
TOTALS					06	05

SITE	STATUS 3	STATUS 4	CONFIRMED	UNCONFIRMED
1 <sup>st</sup>				
2 <sup>nd</sup>				
3 <sup>rd</sup>				
1 <sup>st</sup>				

1<sup>ST</sup> INTERVIEWER: 1111

2<sup>ND</sup> INTERVIEWER:     

YYYY MM DD: 2010 04 30

MODE: 1=BB, 3=PR, 4=MM, 5=CH: 1

STATE: 37

COUNTY: 019

CONTROL NUMBER: 13024

EDITING HOURS (ROUND TO THE NEAREST 0.25 HR): 0.75

ASSIGNMENT INTERVAL: 1=0200-0800, 2=0800-1400, 3=1400-2000, 4=2000-0200: 3

ENCOUNTERED ANOTHER INTERVIEWER: 1=YES, 2=NO IF YES SITE NO: 2

CLUSTER ID: 0007

WEIGH STATION: 1=YES, 2=NO

	INTERVIEW STATUS				
	1 & 2	3	4	5	TOTALS
1 <sup>ST</sup> SITE	11	00	00	00	11
2 <sup>ND</sup> SITE	14	00	02	00	16
3 <sup>RD</sup> SITE	04	00	00	00	04
TOTALS	29	00	02	00	31

3 = Initial Refusal, 4 = Language Barrier, 5 = Refused Key Item

REASON FOR LEAVING SITE	REASON FOR LEAVING SITE CODES
10	06 COULDN'T FIND SITE
10	07 OTHER INTERVIEWER PRESENT
	08 ASKED TO LEAVE
	09 OTHER (SPECIFY IN COMMENTS)
	10 2HR SAMPLING TIME ENDED
	11 END OF 6HR SAMPLING TIME
	12 SITE CLOSED AFTER HOURS (TIME IN COMMENTS)
11	13 SITE CLOSED OTHER (SPECIFY IN COMMENTS)
	14 SITE UNSAFE DURING SAMPLE PERIOD

# Chapter 6. Assignment Summary Form

**2010 MRIP ASSIGNMENT SUMMARY FORM**

NAME: Sally Sampler  
SIGNATURE: Sally Sampler

Do not include intercepted anglers in completed trips section!

1<sup>ST</sup> INTERVIEWER: 1 2 3 4  
2<sup>ND</sup> INTERVIEWER:   
YYYY MM DD: 2 0 1 0 0 7 0 4  
MODE: 1=BB, 3=PR, 4=MM, 5=CH: 4  
STATE: 37  
COUNTY: 031  
CONTROL NUMBER: 23008  
EDITING HOURS (ROUND TO THE NEAREST 0.25 HR): 0.50  
ASSIGNMENT INTERVAL: 1=0200-0800, 2=0800-1400, 3=1400-2000, 4=2000-0200: 3  
ENCOUNTERED ANOTHER INTERVIEWER: 1=YES, 2=NO IF YES SITE NO: 2

SURVEY METHOD: (COMPLETED) ANGLER TRIPS  
1=INTERVIEW, 2=COUNT, 3=BOTH (CONFIRMED BY ANGLER)

START TIME	STOP TIME	SITE	CONFIRMED	UNCONFIRMED
1400	1600	0118	3	02 00
1607	1807	0417	3	05 03
1834	2000	0109	3	02 06
			09	09

COMMENTS:  
118 - 2 anglers left while I was measuring fish but they stopped by to see what I was doing  
417 - terrible fishing  
109 - very busy with lots of anglers coming and going  
← Totals  
Great weather!

SITE	STATUS 3	STATUS 4	CONFIRMED	UNCONFIRMED
1 <sup>ST</sup>	11		11	
2 <sup>ND</sup>		1	111	111
3 <sup>RD</sup>			11	1111

CLUSTER ID: 0004

SITE	INTERVIEW STATUS					INELIGIBLE				REASON FOR LEAVING SITE
	1 & 2	3	4	5	NOT DONE	NOT REC	NOT SALT	NOT FIN		
1 <sup>ST</sup> SITE	07	02	00	00	03	2	00	00	00	10
2 <sup>ND</sup> SITE	13	00	01	00	01	0	00	00	00	10
3 <sup>RD</sup> SITE	21	00	00	00	03	5	00	00	00	11
TOTALS	41	02	01	00	07	7	00	00	00	

WEIGH STATION: 1=YES, 2=NO: 2, 2, 2

3 = Initial Refusal, 4 = Language Barrier, 5 = Refused Key Item

REASON FOR LEAVING SITE CODES:  
06 COULDN'T FIND SITE  
07 OTHER INTERVIEWER PRESENT  
08 ASKED TO LEAVE  
09 OTHER (SPECIFY IN COMMENTS)  
10 2HR SAMPLING TIME ENDED  
11 END OF 6HR SAMPLING TIME  
12 SITE CLOSED AFTER HOURS (TIME IN COMMENTS)  
13 SITE CLOSED OTHER (SPECIFY IN COMMENTS)  
14 SITE UNSAFE DURING SAMPLE PERIOD

# CHAPTER 7. THE FINFISH INTERCEPT INTERVIEW

## General Instructions

The actual interview begins after eligibility has been established and the Privacy Act statement has been read. Copies of the 2010 Intercept Forms for all regions are located in *Appendix A*. General instructions include:

- ✓ **Wording**—All questions to be asked of the angler are written out in full for a purpose. Methodological studies have shown that even slight changes in wording, for example, “should” versus “could,” have the potential to drastically influence item response. You should always read each item on the Intercept Form *exactly* as it is written.
- ✓ **Provide Definitions, Not Answers**—If the angler asks for your opinion about an item, provide a definition for the item in question rather than supplying the actual response. For example, if the angler is unsure about whether he/she was fishing from a head boat or a charter boat (Item 11), you should explain the difference and let the angler decide.
- ✓ **Codes for Not Applicable Questions**—As a general rule, items that are not applicable to a particular angler are coded with “8” as indicated on the Intercept Form.
- ✓ **Codes for Refused Questions**—Items on the Intercept Form that the angler refuses to answer are coded with “9.” If the angler refuses a key item (an item with an asterisk on the Intercept Form), you should code that item with “9” and terminate the interview. If the angler refuses a non-key item (an item without an asterisk on the Intercept Form), code that item with “9” and continue with the next question. An interview with a refused non-key item is considered a Status 2 interview.
- ✓ **Status 5 Intercepts**—All Intercept Forms with a refusal to a key item are Status 5 interviews. These interviews are not considered good interviews, and should not be included on your Assignment Summary Form (ASF) as a completed interview. You should, however, submit these forms and include them as Status 5 on your ASF. Please include Status 5 Intercept Forms at the end of your package. Do not assign an intercept number (Item 5) to any Status 5 interviews.
- ✓ **Codes for Don't Know**—Items on the Intercept Form that the angler does not know the answer to should be coded with “8”, “98”, “998”, “9998”, or “99998” as specified. (Please keep in mind that an interview with a “don't know” answer to a key item is considered a Status 5 interview.)
- ✓ **Right Justify and Add Leading Zeros**—If an answer does not require the use of all boxes provided, you are required to right justify the entry and add leading zeros. For example, if a fish measures 262 mm, the entry, given four coding boxes, should be “0262.”
- ✓ **"Other (SPECIFY)"**—For Items 12, and 14, the response codes are not exhaustive. Separate codes have been designated for “Other (SPECIFY).” If an angler gives a response not covered by the pre-coded responses, you should enter the “other” code, and write out the angler’s exact response in the space provided.



## Chapter 7. The Finfish Intercept Interview

---

- ✓ **Notes/Footnotes**—For some items, notes are required under certain conditions. Examples include: (1) If weight and/or length measurements are missing for Item 31; (2) If a state and/or county code is not in the coding manual and is needed for Item 20; or (3) If a species code is not in the coding manual and is needed for Items 17, 25 or 31. In such cases, place an asterisk (\*) by the item and provide a footnote on the Intercept Form explaining the situation.
- ✓ **Best Use of Time**—There will be times during the day when you will seemingly have little to do. This time can be used to fill in the identifying information on forms that will be used later at that site. This time can also be spent reviewing, editing, and “cleaning up” completed Intercept Forms.
- ✓ **Be Professional**—We expect interviewers to be professional. This includes wearing proper attire when interviewing (e.g., no bathing suits, undershirts, or bare feet). In addition, you are not allowed to fish or drink alcohol during assignments. Eating, smoking, and chewing gum are prohibited while conducting interviews. Remember to maintain objectivity, be polite, say please and thank you, and smile. This little effort will go a long way with an angler.

### Key Items

Several data items are critical to the data expansion routines and are termed key items. If a response to any of the key items is missing, the interview is not valid. **Key items have an asterisk (\*) next to the item number on the Intercept Form.** Key items include mode and area of fishing; distance from shore; state and county of residence; group catch questions (Q.26-29); catch disposition; number of catch by species; and fishing party information (Q.30 & Box D).

### Item-by-Item Instruction

#### Items Completed by the Interviewer

Items two through 10 are questions that you will complete based on information about your assignment and each particular interview—they are not questions that you will ask an angler.

**Item 2-Assignment No.**— This item is prefilled with a “9” for the pilot study.

2. ASSIGNMENT NO.

9
---

Please indicate if this is your first or second assignment by writing '1' or '2'

**Item 3-Interviewer ID**—You will be given a unique four-digit identification number. This number must be used on all submitted forms.

3. INTERVIEWER ID

--	--	--	--

## Chapter 7. The Finfish Intercept Interview

---

**Item 4-Year/Month/Day**—Record the date of the intercept. Two digits should be used for the month and for the date. Please make sure you record the MONTH before the DATE.

4. YR/MO/DAY

--	--	--	--	--	--	--	--

**Item 5-Intercept No.**--Throughout an assignment, consecutively number all good Intercept Forms completed on that assignment. All Status 1 and Status 2 Intercept Forms are considered good, while Status 3, 4, and 5 Intercept Forms are not. Do not number any Intercept Forms that are not considered good.

5. INTERVIEW NUMBER

--	--

At the end of the assignment, the last number used should be the same as the number of good Intercept Forms submitted. Any Status 5 Intercept Forms should be coded as such under "Other Status Interviews" on the ASF (and submitted at the end of the package).

**Item 6-Interview Time**—Using military time, record the time the angler was **completely done fishing**. This procedure is the same for HB mode even though you will start interviewing before the anglers have finished fishing (i.e., you will interview anglers when they are actively fishing and will record the time when they have officially stopped fishing on the trip.). Military time runs on a 24-hour clock starting at 0001 hours (one minute past midnight) and ending at 2400 hours (midnight). For example, 4:45 p.m. should be coded "1645" hours. **Please note that each Intercept Form must have a unique interview time.** If you interview more than one angler at the same time, assign interview times one minute apart. (Example: You finish interviewing a group of three anglers at 1645; the first angler should be assigned an interview time of 1645, the second angler a time of 1646, and the third angler a time of 1647.) **Do not pre-fill out interviewer intercept time; this should be filled in when you begin the interview.**

6. INTERVIEW TIME  
(use 2400 clock)

--	--	--	--

**Item 7-State Code**—Enter the two-digit numerical code for the state of the intercept. State codes can be found in the Intercept Coding Manual. Please note that Puerto Rico, the U.S. Virgin Islands, Guam, and American Samoa have their own two-digit state codes (they are not considered "foreign countries").

3	7
---	---

7. STATE CODE

## Chapter 7. The Finfish Intercept Interview

---

**Item 8-County Code**—Enter the three-digit numerical code for the county of intercept. County codes can be located in your Site Register, or in your Coding Manual. Please note that Puerto Rico and the U.S. Virgin Islands have their own three-digit county codes.

--	--	--

### 8. COUNTY CODE

**Item 9-Site Code**—Enter the four digit numerical code for the site where the interview was conducted. Site codes and names are unique, and are found in the Site Register.

--	--	--	--

### 9. SITE CODE

**Item 10-Interview Status**—This item must be completed at the end of the interview. It serves as an indicator of interview “completeness.” Only interviews of Status 1 or 2 are good interviews, with valid answers to all key items. Interviews of Status 3, 4, and 5 are not considered good interviews.

### 10. INTERVIEW STATUS (key item=\*)

1  Questionnaire  
complete

2  Refused Non-  
Key Item

5  Refused Key Item

**“Questionnaire complete = 1”**—This code should be used if the angler responds to *all items* asked in the interview. In other words, the angler does not refuse to answer any question.

**“Refused non-key items = 2”**—This code should be used if the angler refuses, or is unable to answer, one or more non-key items—but answers all key items. If an angler refuses a non-key item, code that item as “refused” and continue with the next question. If an angler is unable to answer a non-key item, code that item as “don’t know” and continue with the next question. Refusal of a name or phone number, or the angler is a minor are the most common reasons to code an interview as Status 2.

**“Refused key item =5”** – This code should be used if the angler refuses, or is unable to answer one or more key items. If an angler refuses or doesn’t know the answer to a key item code that item as “refused” or “don’t know” and continue with the interview.

### Items Asked of the Angler

Questions 11 through 31 are questions that you will ask each angler. Boxes A, B, C, and D, contain either instructions to the interviewer or items to be recorded by the interviewer—they are not questions asked of the angler. As indicated on the form, before these questions can be administered, you must read the Privacy Act to the angler.

## Chapter 7. The Finfish Intercept Interview

**READ PRIVACY ACT.** This study is being conducted in accordance with the privacy act of 1974. You are not required to answer any question that you consider to be an invasion of your privacy.

**\* Item 11-Fishing From Which Mode?**—You must use discretion in the wording of this question for shore (SH) anglers. Obviously, if an angler is leaving a pier from which no boat fishing was possible, it is inappropriate to ask whether that angler was fishing from a charter boat. For example, a pier angler could be asked: “Would you say you were fishing from a pier, a jetty, or what?” Always include responses from at least two coding categories in the stem of the question. Do not make assumptions about the mode of fishing. There might be piers used by charter/head boats, and it is possible for someone to fish from a dock used primarily by charter/head boats.

**\*11. Would you say you were fishing from:**

- |    |  |   |                                 |
|----|--|---|---------------------------------|
|    | 0 <input type="checkbox"/> Pier              |   | 1 <input type="checkbox"/> Dock |
| SH | 2 <input type="checkbox"/> Jetty, Breakwater | 3 <input type="checkbox"/> Bridge, Causeway |                                 |
|    | 4 <input type="checkbox"/> Other Man-made    | 5 <input type="checkbox"/> Beach/Bank       |                                 |
- 
- |                                     |  |   |  |
|-------------------------------------|--|---|--|
| 6 <input type="checkbox"/> Headboat | 7 <input type="checkbox"/> Charterboat | 8 <input type="checkbox"/> Private Boat | 9 <input type="checkbox"/> Rental Boat |
|-------------------------------------|--|---|--|

All charter boat (CH) and private/rental boat (PR) anglers should be offered all four boat alternatives: “Would you say you were fishing from a head boat, a charter boat, a private boat or a rental boat?” If the angler has difficulty with the definition of a particular mode, provide definitions and let the angler decide. If the angler responds “headboat” thank the angler and terminate the interview. Headboat mode is not included in the Pilot Study.

On occasion, the angler will be unable to give a short answer to Item 11. That is, there might be extenuating circumstances that require a more detailed response. The following examples show how these “detailed” responses should be handled.

IF THE ANGLER SAYS:	CODE:
Bulkhead	2 – Jetty; Breakwater; Breachway
This used to be a bridge but it is now used as a fishing pier.	0 – Pier
I hired and fished from a guide boat.	7 – Charter boat
I boated to a pier/dock/jetty/breakwater/breachway/bridge/causeway; and got out of the boat and fished from the pier/dock/jetty/.../ causeway	0, 1, 2, 3 or 4 – Man-made structure

## Chapter 7. The Finfish Intercept Interview

---

I boated to an oil/gas platform; got out of the boat and fished from the oil/gas platform.	4 – Other man-made structure and write in oil/gas platform
I boated to a beach/bank; got out of the boat and fished from the beach/bank.	5 – Beach or bank
I boated to a barge; got out of the boat and paid to fish	6 – Head boat

**Item 11a-Were you tournament fishing today?** – Anglers are asked whether they were competing in a fishing tournament.

**11a. Were you tournament fishing today?**

1  Yes      2  No      9  Refused

**Item 11b-Did you see any sea turtles while fishing today?** - Anglers are asked whether they saw any sea turtles while they were fishing. Please indicate whether they saw a turtle and if so if it was alive or dead.

**11b. Did you see any sea turtles while fishing today?**

1  Yes, alive      2  Yes, dead      3  No

**Item 12-Type of Water Fished?**—Anglers are asked what type of “water body” they did most of their fishing in. If you know for certain that an angler has given an incorrect response (based on your knowledge of the water bodies in the area, and consultation of the maps in the Coding Manual), record the correct response in Item 12 (not the incorrect response given by the angler).

For a shore (SH) angler, it may not be necessary to ask Item 12. An example of when it’s not necessary to ask is when you have observed the angler fishing and know the correct water body. All boat anglers will have to be asked the question, since boats can travel great distances.

If the angler responds with an answer other than “ocean/gulf,” you will need to probe to determine the correct response. The follow-up probe is: “What (sound/river/bay/inlet) was that?”

## Chapter 7. The Finfish Intercept Interview

---

\*12. Was most of your (specify mode) fishing effort today in the Atlantic Ocean or another waterbody? (If other probe, use DMF waterbody code, and code q. 13 as "8").

- 1  Atlantic Ocean
- 2  Other, (use DMF waterbody code and code 13 as "8"). \_\_\_\_\_

**BOX A.** *If response to Q11 is SH mode AND response to Q12 is "ocean/gulf/open bay" code Q13 as "1," 3 miles or less. (If response to Q 12 is "2" through "G," code Q13 as "Not Applicable")*

If the angler fished in more than one "water body," that angler should be asked in which "water body" the majority of time fishing was spent.

### Bays, Sounds, Rivers, and Inlets:

For item 12 (Type of Water Fished), if the angler responds with an answer other than "ocean/gulf", the interviewer will need to probe to determine the correct response. The follow-up probe is: "What (sound/river/bay/inlet) was that?" For the purposes of the intercept survey refer to the DMF waterbody code list. Note that there are no true sounds on the Atlantic coast.

**\*Note on bays:** The general definition of a bay is an area of water bordered by land on three sides. Bays generally have calmer waters than the surrounding sea, due to the surrounding land blocking some waves and often reducing winds. For the mid-Atlantic states from VA up to NY, many of the bays are located between the mainland and a sandy barrier island, with a narrow inlet that allows passage to the ocean. In the New England states, the bays tend to be rocky "indentations" in the coastline.

**BOX A** If a "1" is coded at Item 12, continue with Item 13. If anything other than a "1" is coded at Item 12, code Item 13 with an "8" and continue with Item 14.

**BOX A.** *If response to Q11 is SH mode AND response to Q12 is "ocean/gulf" code Q13 as "1," 3 miles or less. (If response to Q 12 is "2" through "G," code Q13 as "Not Applicable")*

**\*Item 13**—Please keep in mind that anglers fishing in the shore (SH) mode **AND** fishing in the ocean/gulf (response to Question 12="1") *must* have fished within three miles of shore—therefore there is no need to ask Item 13. In this case, you should automatically mark Item 13 with a "1" (three miles or less.) Otherwise ask:

## Chapter 7. The Finfish Intercept Interview

---

\*13. Was that.....

- 1  Three Miles or Less      8  NC Waterbody  
(does not apply)
- 2  More Than Three Miles

Anglers fishing in the boat modes (PR or CH) in the ocean/gulf bay must be asked Item 13.

Item 13 is used to determine the effort and catch in State versus Federal jurisdictions. State jurisdiction occurs within the State territorial sea, while Federal jurisdiction occurs in open waters beyond the territorial sea. Most States' territorial seas extend three miles from shore.

*Item 13a – Artificial reef?* – This question is asked of all anglers. Refer to the DMF reef code list. If an angler has trouble remembering which artificial reef they fished refer to your artificial reef map.

13a. Were you fishing near an Artificial Reef?

- 01  No      88  SH        If yes, enter reef code  
98=unknown

*Item 13b Boat length?* – This question is asked of all PR and CH anglers. Please record the response in feet.

13b. What was the length of the boat used in feet?   Boat Length

*Item 14-Gear?*—This question is asked of all anglers. If the angler has used more than one type of gear, he/she should be asked which he/she spent more time using. Definitions for fishing gears are:

14. What type of gear was primarily used? (Select only one)

- |  |                                   |   |
|--|-----------------------------------|---|
| 01 <input type="checkbox"/> Hook & Line      | 05 <input type="checkbox"/> Seine | 09 <input type="checkbox"/> Hand                  |
| 02 <input type="checkbox"/> Dip Net, A-frame | 06 <input type="checkbox"/> Trawl | 10 <input type="checkbox"/> Other (Specify) _____ |
| 03 <input type="checkbox"/> Cast Net         | 07 <input type="checkbox"/> Trap  | 98 <input type="checkbox"/> Unknown               |
| 04 <input type="checkbox"/> Gill Net         | 08 <input type="checkbox"/> Spear | 99 <input type="checkbox"/> Refused               |

## Chapter 7. The Finfish Intercept Interview

---

Hook and Line—Traditional rod and reel or hand lines. Trolling, surf fishing, bottom fishing, chum fishing, and fishing with floats are all examples of uses of this gear.

Dip Net—A small hand net consisting of a handle attached to a metal ring with mesh attached, often used to land large fish but also used to catch schools of smaller fish. An example of the use of this gear is to catch baitfish in tide pools.

Cast Net—A large net, weighted around the edges, which is cast out and falls over the fish, thereby entrapping them. This gear is typically used to catch baitfish or shrimp.

Gill Net—A flat net suspended vertically in the water with mesh that allows the fish's head to enter the net but which catches on the fish's gills as it attempts to withdraw.

Seine—A large net with weights on one end and floats on the other used to enclose fish after dragging along the bottom near shore by hand.

Trawl—A large cone-shaped net, which is dragged along the bottom from a boat.

Trap—Usually a metal screen box, extended by a rope, which has bait inside and a small hole, which the fish can swim into but not return. Examples are fish pots and crab traps.

Spear—A sharp, barbed pole that is projected or thrown into the fish. Examples are flounder gigs and SCUBA diving spears.

Hand—Catching fish by hand without the aid of any implements. Examples are picking up fish trapped in tide pools or those chased onto the beach by predators.

Other—If an angler is fishing with anything else than the gears listed here, check this box and record the gear that was used on the line. Examples of “other” gear include a bow and arrow.

***Item 15a-Time Fishing?***—All anglers are asked how many hours they spent fishing with gear in the water in the mode of intercept on that day. If the angler fished at more than one site in the same mode as that of the intercept, he/she should be reminded to include all hours spent fishing in the mode at all sites. If the angler fished at a site in a different mode group, he/she should *not* include time spent fishing in the non-intercept mode.

**15a. To the nearest half-hour, how many hours have you spent (specify mode) fishing today? That is, how many hours have you actually spent with your gear in the water?**

No. of hours

Code as “99.9” if  
DK or Refused

Since a trip is defined as fishing in one mode in one waking day, only waking day hours should be entered. This should never exceed 24.0 hours. You should note that a box with a pre-coded decimal has been provided and that the question requires “to the nearest



## Chapter 7. The Finfish Intercept Interview

---

half hour.” Only “0” or “5” should appear in the last box. As indicated, please enter “99.9” for hours fished if the angler is unable to answer the question or refuses.

**Item 15b-Time on Boat?**—All anglers fishing from a boat are asked how many hours they spent away from the dock, in the mode of intercept on the day of intercept. This question is meant to measure trip time. Do not include time spent in the boat while the boat is at the dock.

Please note that the angler should include the time spent with the gear in the water. **Therefore, 15b should be greater than or equal to 15a.**

**15b. [PR only] To the nearest half-hour, how many hours have you spent on the boat, away from the dock, today?**

<input type="text"/>	<input type="text"/>	<input type="text"/>	No. of hours	Code as “99.9” if DK or Refused
<input type="text"/>	Not Applicable - SH mode			

Please code Item 15b as “Not Applicable” if the angler is fishing from the shore mode. Code as “99.9” if the angler is unable to answer the question or refuses.

**Item 16 – Additional Hours?** This question has been removed from the form since the new field procedures prohibit interviewing beach/bank anglers before they have completed their fishing.

**Item 17-Target Species?**—Ask all anglers to name the kinds of fish they were fishing for. You should enter the species name(s) on the line(s) provided above the coding boxes and look up the code(s) after the interview is completed.

**17. Were you fishing for any particular kinds of fish today? If Yes, what kinds?**

<input type="checkbox"/>	No Particular Species/ Anything
--------------------------	---------------------------------

1<sup>st</sup> Target \_\_\_\_\_

<input type="text"/>	<input type="text"/>	<input type="text"/>	<input type="text"/>	<input type="text"/>	<input type="text"/>
----------------------	----------------------	----------------------	----------------------	----------------------	----------------------

2<sup>nd</sup> Target \_\_\_\_\_

<input type="text"/>	<input type="text"/>	<input type="text"/>	<input type="text"/>	<input type="text"/>	<input type="text"/>
----------------------	----------------------	----------------------	----------------------	----------------------	----------------------

If the angler says “no,” “anything,” or “nothing in particular,” check the box marked “No Particular Species/Anything” and leave the coding boxes blank. If the angler mentions

## Chapter 7. The Finfish Intercept Interview

---

only one species, it should be coded under “1<sup>st</sup> Target,” with “2<sup>nd</sup> Target” left blank. If the angler names two or more species, code only the first two mentioned.

Because we would like the most specific fish identification possible, if the angler names a family of fish, you should probe to determine whether he/she preferred a particular species in that family. For example: If the angler responds “drum”, your response should be “Did you target any particular kind of drum?” If the angler has no preference within the family of fish, and several species are possible within that family, enter the family code. If, however, you know that the angler could only be going after one species within that family, enter that species code. For this item, knowledge of how local names translate to exact species is very important. If the angler uses a local name for a fish, enter the accepted common name on the intercept form, and make a note of it in the comments section or next to the accepted common name. A list of local names and the corresponding accepted common names is found in the Coding Manual.

You should only record reasonable responses to this item. If an angler responds that he/she was fishing for a species not found in the area, this response should not be coded. For example, it is not reasonable that anyone would fish for oceanic pelagic species like blue marlin from an inland pier.

**Item 18-Days in Past 12 Months?**—All anglers are asked how many days they have been saltwater sport finfishing in the state of intercept, or from a boat launched in the state of intercept, **excluding the day of intercept**, in the past 12 months.

**18. Not counting today, within the past 12 months, that is since (insert month) of last year, how many days have you gone saltwater sport fin fishing in NC or from a boat launched in NC?**

--	--	--

No. of days

998

--

Don't know

999

--

Refused

The wording of this item is very important. The angler should think back to the same date in the previous year. He/she should **not** include days spent freshwater fishing; commercially fishing, shellfishing, or days spent fishing in other states.

You may have to work with an angler to come up with a specific number. Anglers are likely to say something like “every week” or “once a month.” In these instances, you should translate the response to a number and verify that number with the angler.

Because the day of intercept is not included, the maximum number of days that can be entered for this item is “364,” and the minimum acceptable entry is “000” (meaning that the day you are interviewing them is the only day in the last 12 months that they have

## Chapter 7. The Finfish Intercept Interview

---

been saltwater finfishing). Please code Item 18 as “998” for “Don’t Know” and “999” for “Refused.”

**Item 19-Days in Past Two Months?**—Anglers are also asked how many days they have been saltwater sport finfishing in the state of intercept, or from a boat launched in the state of intercept, **excluding the day of intercept**, in the past two months.

**19. Not counting today, within the past 2 months, how many days?**

No. of days

998  Don't know

999  Refused

Since the question requires days, and the day of intercept should not be included, the maximum number of days that can be entered for item 19 is “61.” The minimum number of days is “00” (meaning that the day you are interviewing them is the only day in the last two months that they have been saltwater finfishing). Please use code “998” for “Don’t Know” and code “999” for “Refused.”

It is important that you check the answer to Item 19 against the answer to Item 18. The number of days in Item 19 cannot be greater than the number of days in Item 18. (Item 18 includes the two months from Item 19.)

**\* Item 20-Residence?**—All anglers are asked their state and county of residence. If the angler does not know his/her county of residence, enter the city name and circle “city” on the Intercept Form. In that case, the coding boxes for county would be left blank. DMF staff will use alternate sources to locate the correct county code. **Please keep in mind that the intercept will become a Status 5 if staff is unable to locate the correct county code.**

**\*20. What is your state and county of residence?**

*If county unknown, ask: What city or town do you live in?*

State code: Name \_\_\_\_\_

County code: Name \_\_\_\_\_

If asked by angler, you should clarify that we would like to know the state and county of the angler’s *legal* residence. After completing the interview, use the Coding Manual to fill in the correct state and county codes.

If an angler is a resident of some country other than the United States, please write the country name on the line provided, leave the state code blank, and fill in “998” for the county code. All foreign countries are assigned a county code of “998.” Please note that

## Chapter 7. The Finfish Intercept Interview

---

Puerto Rico and the U.S. Virgin Islands are not considered foreign countries, and are included in your Coding Manual. Please make sure you complete the county information for these as you would with any other state.

**Item 21-ZIP Code?**—All anglers are asked for the ZIP Code of their residence. The ZIP Code given should be of the residence named by state and county in Item 20. Again, if asked, explain that we are looking for the angler’s legal residence. If an angler is a resident of some country other than the United States, check the box labeled “99997.” “99998” should be used for “Don’t Know” and “99999” for “Refused.”

### 21. What is the zip code of your residence?

<input type="text"/>	<input type="text"/>	<input type="text"/>	<input type="text"/>	<input type="text"/>	Zip Code
99998	<input type="checkbox"/>	Don't Know			
99999	<input type="checkbox"/>	Refused			
99997	<input type="checkbox"/>	Foreign Country			

**Item 22-Type of Residence?**—All anglers are asked what type of residence they live in. Single family homes and apartments are considered “private residences.” Dorms, barracks, nursing homes, and rooming houses are considered “institutional housing units.” Please make sure that you code Item 23 as “8” if the angler lives in institutional housing.

### 22. Do you live in a private residence, or in some type housing such as a dorm, barracks, nursing home or rooming house?

1	<input type="checkbox"/>	Private Residence	8	<input type="checkbox"/>	Don't Know
2	<input type="checkbox"/>	Institutional Housing (Code Q.23 as 8 and skip to 23a)	9	<input type="checkbox"/>	Refused

**Item 23-Has Phone?**—This is asked of all anglers, except those living in institutional housing. The intent of this question is to determine whether or not their home has a landline telephone (that is, a residential phone line to their home that is used for private telephone calls, as opposed to using only a cell phone for all calls). It is important that you inform the angler that he/she does not necessarily have to provide his/her home telephone number under Item 24, if he/she answers this question.

## Chapter 7. The Finfish Intercept Interview

---

23. Does your home have a landline telephone?  
That is, a telephone *other than* a cellular phone?

1  Yes    2  No    8     9  Refused

**Item 24-Name and Phone Provided?**—All anglers are asked for their name and a telephone number for survey verification. Survey verification is an important quality control step and demonstrates that our interviewers are conducting the survey as required. Names and phone numbers should be written in the space provided. You should make sure that an area code is included.

If the angler is a minor, do not ask for a phone number for verification. Instead, check both boxes (name and/or phone number not given and angler aged 16 years or younger), and the questionnaire becomes a Status 2. Make sure that you check question 10 as “2-Refused non-key item.”

It is not necessary to obtain the angler’s home telephone number. Any number at which he/she can be reached is acceptable. Please note that failure to obtain the angler’s name and a phone number will make the interview a Status 2 even if all other questions have been completed.

Each interviewer is required to obtain names and phone numbers for at least 75% of all intercepts.

**Item 23a-Sex** – Please indicate the gender of the angler.

**Item 23b-Age** – Please indicate the age of the angler on their last birthday. If they refuse to give a name and phone number check name and phone not given. If an angler is age 16 or under we do not collect name and telephone numbers. Please check both “Name and Phone not given” and “Angler age 16 or under”.

---

<input type="checkbox"/>	<input type="checkbox"/>	<input type="checkbox"/>	–	<input type="checkbox"/>	<input type="checkbox"/>	<input type="checkbox"/>	–	<input type="checkbox"/>	<input type="checkbox"/>	<input type="checkbox"/>	<input type="checkbox"/>
<input type="checkbox"/>	Name and Phone not given					<input type="checkbox"/>	Angler age 16 or under				

24. In the event my supervisor wishes to verify that I have been conducting interviews here today, may I have a name and home phone number?    Day    Night

## Chapter 7. The Finfish Intercept Interview

\* **Box B**—Check the box “not a headboat ride” for every interview. As stated earlier, headboat mode is not being covered in the Pilot Study.

<p>BOX B.. [If headboat ride-along:] Is this one of the anglers you monitored for discard (Type 9) catch?</p> <p> <input type="checkbox"/> Yes              <input type="checkbox"/> No              <input type="checkbox"/> Not a headboat ride         </p>
--

\* **Item 25-Unavailable Catch (Type 2 Records)?**—All anglers are asked to report on fish caught in the mode of intercept that are not available for inspection. Unavailable fish should be entered at Item 25 on the Intercept Form.

**25. UNAVAILABLE CATCH.** Did you land any fish that are not here for me to look at? For example, any that you may have thrown back or used for bait? IF YES, COMPLETE TYPE 2 RECORD FOR THIS INDIVIDUAL ANGLER ONLY. DO NOT INCLUDE ANY CATCH THAT WAS CAUGHT BY ANOTHER ANGLER. UNGROUPED CATCH ONLY. NOTE: FILLETS ARE UNAVAILABLE CATCH.

TYPE 2 RECORDS		NOT GROUP CATCH				DISPOSITION CODES					
		SPECIES CODE						DISP		# OF FISH	
1	_____										
2	_____										
3	_____										
4	_____										
5	_____										

**DISPOSITION CODES**

1. Thrown back alive/legal
2. Thrown back alive/not legal/legality ref.
3. Eaten/plan to eat
4. Used for bait/plan to use for bait
5. Sold/plan to sell
6. Thrown back dead/plan to throw back
7. Some other purpose
8. Don't know / Didn't ask
9. Refused

**PLEASE NOTE:** Any fish that YOU are unable to positively identify AND count MUST be recorded as "unavailable catch" (under Item 25). You must count and identify **each** fish in order for it to be recorded as "available catch" (Item 31). NMFS and DMF maintain this rule because we are confident in your ability to identify fish to the species-level and to accurately count how many there are of each species. **However, we are not confident in all anglers' ability to accurately identify fish to the species-level. Even one misidentified fish will result in the recording of inaccurate information, which is one reason why we need to record all information reported by anglers as "unavailable catch."**

It is possible to record some fish of the same species as "unavailable catch" and other fish as "available catch." If an angler tells you that he has five Atlantic Cod in a cooler, and you are only allowed to positively identify and count three of them, you should record the three Atlantic Cod as "available catch" and the other two as "unavailable catch." You cannot be sure that the other fish were Atlantic Cod or that there were two of them, if you were unable to see them. Please call project staff if you have any questions about this. It is very important that you understand the proper procedures regarding "unavailable" and "available catch."

A separate line must be filled in for each unique species-disposition combination. Each line of information is called a "Type 2" record. Each "Type 2" record must contain a species name, a six-digit species code, the number of fish, and a disposition code.

## Chapter 7. The Finfish Intercept Interview

---

Species name and code, number of fish, and disposition are key items. Never leave any of these items blank! It is also important that you write out the full species name (be sure to use the accepted common name). **Abbreviations are not acceptable.**

You should strive to report an angler's Type 2 catch to the species-level. Since you cannot inspect or count unavailable catch, it is recognized that the species and numbers reported may not be exact. It is appropriate to show the anglers pictures from the field guide in order to clarify a fish species. If it is not possible to obtain a species-level identification, please record to the appropriate code, as close to the species-level as possible. If necessary, one of the “unidentified fish” codes may be used as a last resort.

**NOTE:** If an angler refuses to allow you to see or count his/her catch, but he/she reports the catch, list the catch in Type 2. This interview is still considered good because the angler reported his/her catch.

The question to ask concerning disposition is: “What did you do or do you plan to do with the (species name)?” You may have to probe until the ultimate disposition of the fish is determined. For example, disposition code "3" should be used if the angler gives the fish to his friend, who is planning to eat it.

The disposition codes can be found below Item 25 on the Intercept Form. They include: (1) Thrown back alive/legal; (2) Thrown back alive/not legal/legality ref.; (3) Eaten - plan to eat; (4) Used for bait - plan to use for bait; (5) Sold - plan to sell; (6) Thrown back dead - plan to throw away; and (7) Plan to use for some other purpose.

Please limit your use of disposition seven, “some other purpose.” It should only be used if the angler’s response is unusual and does not fall under dispositions one through six. (If you use disposition seven, NOAA Fisheries requires that the purpose be documented—so write the angler’s response on the form in available white space.)

**NOTE:** There is no code for “given away.” If the fish have been given away, ask what the recipient intends to do with the fish and code accordingly. For example, if the fish were given away to be used for bait, the correct disposition would be "4.”

Please remember that disposition eight, “don’t know/didn’t ask” and disposition nine “refused” cannot be used for unavailable fish. The use of these two codes will result in a Status 5 interview.

All filleted fish should be considered “unavailable catch” and entered under Item 25. However, if enough of the carcass is left to allow for accurate species identification and an accurate count, the fish can be entered as “available catch” under Item 31. Please note “Identified from rack” next to the species for any fish you identify from the carcass.

Anglers may think that fillets are available catch and not report them in response to the question at Item 25. If you should look at an angler’s catch and discover that all of the fish have been filleted, the fillets must be entered as “Type 2” records, and there would be no “Type 3” records. Please note that you *should not assume* that all fillets would be eaten. Even with fillets, it is important to ask the question concerning disposition.

## Chapter 7. The Finfish Intercept Interview

**Each angler must report on his/her own unavailable catch.** If a group of anglers report that they together caught a certain number of fish, and that these fish have been filleted, you should strive to determine how many fish each angler caught. If the angler has been on an overnight fishing trip, record unavailable catch only for the most recent day of fishing; an angler's recollection of unavailable catch is unreliable beyond the most recent day of fishing.

Remember that "Type 2" catch is for individual anglers only. The catch of other anglers in the party is never included in an angler's individual catch. It is important to remember that captains' and mates' catch must not be included here because they are not considered recreational anglers and therefore their catch cannot be recorded in this survey.

If one species is disposed of in two or more manners, it will be necessary to complete two or more "Type 2" records for the species. For example, if an angler caught a total of eight bluefish, five of which he/she threw back alive, and three of which he/she plans to eat, you should complete two "Type 2" records. The first "Type 2" record would be five bluefish with disposition 1, and the second "Type 2" record would be three bluefish with disposition 3.

**\*25. UNAVAILABLE CATCH.** Did you land any fish that are not here for me to look at? For example, any that you may have thrown back or used for bait? IF YES, COMPLETE TYPE 2 RECORD FOR THIS INDIVIDUAL ANGLER ONLY. DO NOT INCLUDE ANY CATCH THAT WAS CAUGHT BY ANOTHER ANGLER. UNGROUPED CATCH ONLY. NOTE: FILLETS ARE UNAVAILABLE CATCH.

TYPE 2 RECORDS		SPECIES CODE				DISP		# OF FISH		DISPOSITION CODES		
1	bluefish	1	6	8	5	5	9	1	0	0	5	1. Thrown back alive/legal 2. Thrown back alive/not legal/legality ref. 3. Eaten/plan to eat 4. Used for bait/plan to use for bait 5. Sold/plan to sell 6. Thrown back dead / plan to throw back (comment required) 7. Some other purpose 8. Don't know / Didn't ask 9. Refused
2	↓							3	0	0	3	
3												
4												
5												

The Intercept Coding Manual also contains codes to be used when the species of a fish is unknown. While these cannot be used when inspecting available fish, they may be needed for fish unavailable for inspection (Item 25). These codes are the following:

Unidentified Catfishes 163992  
 Unidentified Eel 161123  
 Unidentified Fish 161030  
 Unidentified Flounder or Sole 172702  
 Unidentified Sharks 159786  
 Unidentified Skate or Ray 160806

**NOTE:** Use these codes ONLY as a last resort. Do everything you can to get a more accurate identification.

Three coding boxes are provided for "Number of Fish" under Item 25. As stated above, this is the number of fish of the listed species-disposition combination caught by an



## Chapter 7. The Finfish Intercept Interview

---

individual angler. Since Item 25 is a key item, there are no “don't know” or “refused” codes reserved for “Number of fish.” A number must be entered! (“998” will be read as nine-hundred and ninety-eight fish instead of a disposition code!)

Five lines have been provided on the Intercept Form for "Type 2" records. If more than five are needed, you should use the second page of a clean Intercept Form. Both the additional and the original form must be clearly marked with “page 1 of 2” and “page 2 of 2.” You must fill out Items 2 through 10 on the second page and these items must match Items 2 through 10 on the first page.

**Item 26-Were Fish Caught To Look At?**—All anglers are asked whether they caught any fish in the mode of intercept that the interviewer can examine and count. If the angler caught some fish that are available for inspection and can be counted, and the fish were harvested, you should code Item 26 as “Yes” and continue with Item 27. This angler must have some data recorded as available catch (Item 31.).

**Interviewer Note:** Even if an angler allows you to identify, count, and/or weigh and measure a fish, but the fish will be released, Question 26 should be coded as “2” and no catch should be recorded under Item 31 (which refers only to harvested catch).

**\*26. Did you catch any fish while you were fishing that I might look at?**

1	<input type="checkbox"/>	Yes	
2	<input type="checkbox"/>	No	Code q. 27, 28, 29 as “8’s” Not Applicable
3	<input type="checkbox"/>	Yes, BUT fish on another angler’s form. Fill in interview # where fish are listed	→ <input type="text"/> <input type="text"/>
		Code q. 27, 28, 29 as “8’s” Not Applicable	

If the angler did not catch any fish available for inspection, or he/she did not allow you to identify or count the catch, code Item 26 as “No,” code Items 27 through 29 as “8” (“Not Applicable”), and continue with Item 30. This angler should not have data recorded as available catch (Item 31), but should have an entry at Item 30.

If the angler caught fish that are available for inspection, but they have already been entered on another angler's form because they could not be separated, you should code Item 26 as “3 - Fish on another angler’s form.” You should then enter the interview number where the fish are located in the boxes provided. Code Items 27 through 29 as “8” and continue with Item 30. This angler should have no data recorded as available catch (Item 31), but should have an entry at Item 30.

You should note that Item 26 includes the words “to look at.” Fish that have been filleted are not considered available “to look at.” If it turns out that the angler’s fish have all been filleted, you will have to go back and change the angler’s response to Item 26. Filleted fish are entered as unavailable catch (Item 25), **not** as available catch (Item 31).

## Chapter 7. The Finfish Intercept Interview

---

\* **Item 27-Catch Mixed?**—This question is asked *only* of those anglers who caught fish available for inspection and whose fish have not been entered on another angler's form. If Item 27 is not applicable, it should be coded as "8."

If the angler caught all of the available fish, code Item 27 as "1 - All Caught by Angler," code Items 28 and 29 as "8" representing "not applicable," and continue with Item 30.

If other anglers have contributed to the available catch, code Item 27 as "2 - Other Contributors" and continue with Item 28.

**\*27. Did you catch these yourself or did someone else catch some of them?**

- 1  All caught by angler - Code q. 28, 29 as "8's"  
Not Applicable
- 2  Other contributors
- 8  Not Applicable

\* **Item 28-Separate Catch?**—This question is asked *only* of those anglers who report that several anglers have contributed to their available catch at Item 27. If Item 28 is not applicable, it should be coded as "8." Some anglers may be able to partially separate their catch. For example, Moe and Larry catch five fish between them, and Larry says he caught the two smallest plus one more which he cannot point out. Record this on the form as "2 - NO" cannot separate, because the angler has to be able to separate *all* fish, not just some of them.

If the angler can separate out his/her own available catch, code Item 28 as "1 - Yes," code Item 29 as "88" and continue with Item 30. **Only the angler's own available catch should then be entered as available catch (Item 31).**

If the angler cannot separate out his/her own available catch, code Item 28 with "2 - No" and continue with Item 29. **All of the available catch would then be entered on this angler's form as available catch (Item 31).**

**\*28.Can you separate out your individual catch?**

- 1  Yes, Code 29 as "88"      2  No      8  Not Applicable

\* **Item 29-Number Who Caught Fish?**—This question is asked only of those anglers who cannot separate their available fish from the available fish caught by others in their fishing party ("No" at Item 28.) If Item 29 is not applicable, it should be coded as "88."

## Chapter 7. The Finfish Intercept Interview

\*29. How many anglers, including yourself, have their catch here?

Please do not include anyone who did not catch fish.

		No. of contributors	88		Not Applicable
--	--	---------------------	----	--	----------------

The angler is asked to indicate the number of anglers who contributed to the total available catch. Do not include anyone who did not catch any of the available fish. That person should be interviewed separately if he/she spent any time fishing. **The count of contributors should only include anglers who caught one or more of the fish recorded under Item 31 on that angler's form. Captains and mates in CH modes are never included as contributors, because they are not recreational anglers. However, their catch should be included in the anglers' catch.** As stated above, all of the available catch would then be entered on this angler's form at Item 31.

The following are the five possible ways to code Items 26 through 29:

IF THE ANGLER SAYS:	CODE:
This angler has no available catch. S/he has not caught any fish that the interviewer can look at.	Q26=2
	Q27=8 – Not applicable
	Q28=8 – Not applicable
	Q29=88 – Not applicable
This angler has available catch. The angler has caught fish that the interviewer can look at and count, and the angler has caught them all.	Q26=1
	Q27=1
	Q28=8 – Not applicable
	Q29=88 – Not applicable
This angler has available catch. S/he is part of a group of five anglers who all caught fish. S/he cannot separate his/her share of the catch. All of the group's available catch is listed on this angler's form.	Q26=1
	Q27=2
	Q28=2
	Q29=05 – Number of anglers who caught fish – cannot separate
This angler's available catch is part of a group catch. His/her available catch has been reported on the form of an angler in the group who was already intercepted. For example, if the anglers catch was reported on the first angler in the group who was intercepted that day (meaning intercept number "01"), then complete item 26 as shown.	Q26=3 – Record the intercept number ("01" in this example) in the space provided to indicate which form his/her catch is located on
	Q27=8 – Not applicable
	Q28=8 – Not applicable

## Chapter 7. The Finfish Intercept Interview

	Q29=88 – Not applicable
This angler has available catch. S/he is part of a group. Each angler, though, can separate his/her share of the catch from that of the group.	Q26=1
	Q27=2
	Q28=1
	Q29=88 – Not applicable

Several examples of different catch scenarios have been provided below.

**Example 1:** Angler without Available Catch; this angler did not catch any fish.

\*26. Did you catch any fish while you were fishing that I might be able to look at?

1  Yes

2  No - Code Q27, Q28, Q29 as "Not Applicable"

3  Yes, BUT fish on another angler's form - Fill in interview # where fish are listed  
  Code Q27, Q28, Q29 as "Not Applicable"

\*27. Did you catch these yourself or did someone else catch some of them?

1  All Caught by Angler - Code Q28, Q29 as "Not Applicable"

2  Other Contributors 8  Not Applicable

\*28. Can you separate out your individual catch?

1  Yes - Code 29 as "Not Applicable"

2  No 8  Not Applicable

\*29. How many anglers including yourself have their catch here? Please do not include anyone who did not catch fish. Only count those who have their catch here.

No. of Contributors 88  Not Applicable

BOX C. If q. 11 is SH mode, code q. 30 as "888," and Code Box D as "8."

\*30. How many people fished on your boat today?

No. of People 888  Shore Mode

0 0 4

\*BOX D. If response to Q30 is 1, code as "Not Applicable." Otherwise, is this the first angler from this boat that I have interviewed?

1  Yes 8  Not Applicable

2  No - Record interview # of 1st angler in the fishing party.

0 7

**Example 2:** Angler with Available Catch; this angler caught all the fish in his cooler by himself.

\*26. Did you catch any fish while you were fishing that I might be able to look at?

1  Yes

2  No - Code Q27, Q28, Q29 as "Not Applicable"

3  Yes, BUT fish on another angler's form - Fill in interview # where fish are listed  
  Code Q27, Q28, Q29 as "Not Applicable"

\*27. Did you catch these yourself or did someone else catch some of them?

1  All Caught by Angler - Code Q28, Q29 as "Not Applicable"

2  Other Contributors 8  Not Applicable

\*28. Can you separate out your individual catch?

1  Yes - Code 29 as "Not Applicable"

2  No 8  Not Applicable

\*29. How many anglers including yourself have their catch here? Please do not include anyone who did not catch fish. Only count those who have their catch here.

No. of Contributors 88  Not Applicable

BOX C. If q. 11 is SH mode, code q. 30 as "888," and Code Box D as "8."

\*30. How many people fished on your boat today?

No. of People 888  Shore Mode

0 0 6

\*BOX D. If response to Q30 is 1, code as "Not Applicable." Otherwise, is this the first angler from this boat that I have interviewed?

1  Yes 8  Not Applicable

2  No - Record interview # of 1st angler in the fishing party.

0 3

## Chapter 7. The Finfish Intercept Interview

**Example 3:** Angler with Available Catch but catch is grouped. This angler has a cooler of fish, and those that are in it belong to him and another angler. They cannot separate which one of them caught which fish.

\*26. Did you catch any fish while you were fishing that I might be able to look at?

1  Yes

2  No - Code Q27, Q28, Q29 as "Not Applicable"

3  Yes, BUT fish on another angler's form - Fill in interview # where fish are listed

Code Q27, Q28, Q29 as "Not Applicable"

\*27. Did you catch these yourself or did someone else catch some of them?

1  All Caught by Angler - Code Q28, Q29 as "Not Applicable"

2  Other Contributors §  Not Applicable

\*28. Can you separate out your individual catch?

1  Yes - Code 29 as "Not Applicable"

2  No §  Not Applicable

\*29. How many anglers including yourself have their catch here?  
Please do not include anyone who did not catch fish. Only count those who have their catch here.

No. of Contributors 88  Not Applicable

BOX C. If q. 11 is SH mode, code q. 30 as "888," and Code Box D as "8."

\*30. How many people fished on your boat today?

No. of People 888  Shore Mode

\*BOX D. If response to Q30 is 1, code as "Not Applicable." Otherwise, is this the first angler from this boat that I have interviewed?

1  Yes 8  Not Applicable

2  No - Record interview # of 1st angler in the fishing party.

**Example 4:** Angler with Available Catch but catch on another angler's form. This angler caught fish, and they are in the same cooler as the fish from Example 3. He cannot separate out his own catch.

\*26. Did you catch any fish while you were fishing that I might be able to look at?

1  Yes

2  No - Code Q27, Q28, Q29 as "Not Applicable"

3  Yes, BUT fish on another angler's form - Fill in interview # where fish are listed

Code Q27, Q28, Q29 as "Not Applicable"

\*27. Did you catch these yourself or did someone else catch some of them?

1  All Caught by Angler - Code Q28, Q29 as "Not Applicable"

2  Other Contributors §  Not Applicable

\*28. Can you separate out your individual catch?

1  Yes - Code 29 as "Not Applicable"

2  No §  Not Applicable

\*29. How many anglers including yourself have their catch here?  
Please do not include anyone who did not catch fish. Only count those who have their catch here.

No. of Contributors 88  Not Applicable

BOX C. If q. 11 is SH mode, code q. 30 as "888," and Code Box D as "8."

\*30. How many people fished on your boat today?

No. of People 888  Shore Mode

\*BOX D. If response to Q30 is 1, code as "Not Applicable." Otherwise, is this the first angler from this boat that I have interviewed?

1  Yes 8  Not Applicable

2  No - Record interview # of 1st angler in the fishing party.

## Chapter 7. The Finfish Intercept Interview

**Example 5:** Angler with available catch that is NOT grouped. This angler caught fish, they are in a cooler with everyone else's, but he knows exactly which fish he caught.

\*26. Did you catch any fish while you were fishing that I might be able to look at?

1  Yes

2  No - Code Q27, Q28, Q29 as "Not Applicable"

3  Yes, BUT fish on another angler's form - Fill in interview # where fish are listed  
  Code Q27, Q28, Q29 as "Not Applicable"

\*27. Did you catch these yourself or did someone else catch some of them?

1  All Caught by Angler - Code Q28, Q29 as "Not Applicable"

2  Other Contributors 8  Not Applicable

\*28. Can you separate out your individual catch?

1  Yes - Code 29 as "Not Applicable"

2  No 8  Not Applicable

\*29. How many anglers including yourself have their catch here?  
 Please do not include anyone who did not catch fish. Only count those who have their catch here.

No. of Contributors 88  Not Applicable

**BOX C. If q. 11 is SH mode, code q. 30 as "888," and Code Box D as "8."**

\*30. How many people fished on your boat today?

No. of People 888  Shore Mode

**BOX D. If response to Q30 is 1, code as "Not Applicable." Otherwise, is this the first angler from this boat that I have interviewed?**

1  Yes 8  Not Applicable

2  No - Record interview # of 1st angler in the fishing party.

**BOX C-Identify Boat Mode Intercepts**—If the angler was fishing from the shore mode, (as indicated in Item 11), Item 30 and Box D should be coded as “Not Applicable.”

**BOX C. If q. 11 SH mode, code q. 30 as “88” and box D as “8.”**

\* **Item 30-Party Size?**—This question is asked to determine how many anglers fished on the boat, *including* the angler being interviewed. If the angler fished alone on a boat, code as “001.” If the angler was fishing from the shore, code as “Shore Mode.”

\*30. How many people fished on your boat today?

No. of people 88  Shore Mode

For this survey, a “fishing party” is defined as a group of anglers who fished on the same boat on the same day. Therefore, all anglers fishing from the same boat are considered members of the same “fishing party” regardless of whether they traveled together to the site. In addition, all anglers fishing from the same charter/head boat should be considered members of the same fishing party. Please note that the number of people on the boat must be identical for anglers in the same party. If anglers of the same fishing party report a different number of people on the boat, it may be because they do not know the exact number. In this case, clarify the number on the boat by asking the mate or captain, if possible. Never assume that everyone on the boat actually fished.

Please keep in mind that the number of contributors recorded in Item 29 cannot exceed the number of anglers in a “fishing party.”

## Chapter 7. The Finfish Intercept Interview

---

\* **Box D-First Person from Boat?**—This question applies to those anglers who fished from a boat and who responded that the number of people on the boat (Item 30) was greater than one. Box D must be coded as “8 – Not Applicable” if the response to Item 30 is “001,” or if the angler was fishing in shore mode (Item 11).

If the angler indicated in Item 30 that he/she fished together with other anglers on the same boat, then ask yourself: “Is this the first person on the boat that I have interviewed?” If the response is “yes,” code Box D as “1 - Yes.” If he/she is not the first interviewed, code as “2 - No” and record the interview number of the first angler in the party in the boxes provided.

**Note:** Item 30 and Box D are “key items”. Box D contains a question not to be asked of the angler. Rather, it is to be filled in by you after the interview is completed.

<b>BOX D. If response to q. 30 is 1, code as “8” Not Applicable. Otherwise, is this the 1st angler from this boat that I have interviewed?</b>			
1	<input type="checkbox"/>	Yes	8 <input type="checkbox"/> Not Applicable
2	<input type="checkbox"/>	No	Record interview # of 1st angler in the fishing party <input type="text"/> <input type="text"/>

30a. *Vessel On List/Vessel Name*—

**30a. Is vessel on DMF List?**

1  Yes    2  No    3  Non-coop.    8  SH or PR

**No Name** Record Vessel ID to determine “on list” status. If “on list” cannot be confirmed, Q10 = Status 5. (*Note: This question must be completed for all charter and head boat interviews, regardless of mode of assignment).*)

You should refer to the vessel directory “Good List” for your state to determine if the vessel from which you are intercepting anglers is included on the list (yes or no). **In either case**, the interviewer should write out the full name of the vessel, **exactly** as it appears on the vessel directory, and check either “yes” or “no”. If the name of the boat is listed incorrectly or incompletely on the vessel directory, please write a note in the comments section explaining that the current name is incorrect, and noting the correct name. The correct name is that which appears on the vessel, and must match the name in the vessel directory. Note that more than one vessel may have the same name so you

## Chapter 7. The Finfish Intercept Interview

should document other identifying information (such as registration number or Coast Guard ID number) whenever possible.

If the vessel does not have a name, use and record other identifying information (vessel ID, captain's name and homeport) to determine if the vessel is on the list. If you cannot positively determine if the vessel is on the list or not, the interview must be coded as a Status 5.

\* **Item 31-Available Catch (Type 3 Records)?**—The angler's harvested, available catch should be entered at Item 31 on the Intercept Form. Each line of information recorded is called a "Type 3" record. Each "Type 3" record **MUST** have the following information:

- ✓ Species name (common name, as indicated in your Coding Manual)
- ✓ The corresponding six-digit species code (also from your Coding Manual)
- ✓ The total number of that species (all counted by you) and
- ✓ The disposition code (indicating what the angler plans to do with the **majority** of the fish of that species), valid responses would be those three through nine

\*31. AVAILABLE CATCH, COMPLETE TYPE 3 RECORD BY ASKING: May I look at your fish? What do you plan to do with the MAJORITY of the species.

TYPE 3 RECORDS	SPECIES CODE	# OF FISH	LENGTH (mm)	WEIGHT (kg)	DISP
1 _____					
2 _____					
3 _____					
4 _____					
5 _____					
6 _____					
7 _____					
8 _____					
9 _____					
10 _____					
11 _____					
12 _____					

Without this information, the intercept is considered a Status 5 interview, and cannot be used. If the angler is in somewhat of a hurry and won't allow you to weigh and measure the fish, weights take priority over lengths.

**REMEMBER:** You must positively identify and count **ALL** fish that you record under the "available catch" section (Item 31). If you are only able to identify and count some of the fish, those that are identified and counted should be recorded under the "available catch" section (Item 31), and those that are not should be recorded under the "unavailable catch" section (Item 25).



## Chapter 7. The Finfish Intercept Interview

---

**NOTE: Using disposition 1 in the Type 3 catch is *not* allowed**, even if you saw the fish and were able to obtain a length and weight before the fish was thrown back. If the ultimate disposition of the fish is “1-thrown back alive,” and therefore not actually harvested, it belongs in the Type 2 or “unavailable catch” section (Item 25). Code Item 26 as “No,” code Items 27 through 29 as “8” (“Not Applicable”) and continue with Item 30.

When more than one fish of a species is available, you do not need to repeat the species name, the species code, the total number of fish, or the disposition code on all lines. In that case, draw arrows down, indicating that the boxes are exactly the same as the ones above. **This only holds true, however, for the species name, the species code, total number, and disposition. If the weights and lengths are the same, they must be written out. As with unavailable catch, it is important that you write out the full species name (be sure to use the accepted common name). Abbreviations are not acceptable.**

If 10 or fewer fish of one species are available, weigh and measure all of them. If more than 10 fish of one species are available, you should **randomly** select 10 fish to be weighed and measured (see *Chapter 9, Sub-Sampling Procedures*). No more than 10 fish of one species should be weighed and measured per angler. **If the catch is grouped, and there are more than 10 fish of one species, you should attempt to weigh and measure up to 10 fish per species per angler.**

**EXAMPLE 1:** If 17 bluefish are in a cooler, and the catch is grouped with two anglers contributing to the catch, you weigh and measure all 17 bluefish.

**EXAMPLE 2:** If 7 spot are in a cooler, and the catch belongs to one angler, you weigh and measure all 7 spot.

**EXAMPLE 3:** If 32 bluefish are in a cooler, and the catch is grouped with two anglers contributing to the catch, you weigh and measure no more than 20 of those fish (2 anglers x 10 fish each = 20 fish).

**EXAMPLE 4:** You are weighing and measuring Type 3 catch for two anglers: there are 27 scup, seven summer flounder, and two striped bass. You have weighed and measured 12 scup, (no summer flounder or striped bass) when the anglers indicate that they want to leave, and you only have time to weigh and measure a couple more fish. It is okay and preferred for you to stop weighing and measuring the scup and get weights and lengths on some (if not all) of the summer flounder and striped bass.

Three coding boxes have been provided for “# of Fish” in Item 31. As stated in the discussion of Item 25, no codes have been reserved for “don’t know” and “refused.” A “999” will be read as nine-hundred and ninety-nine fish. Numbers above three digits, that is, above “999,” should be written out in the available space.

**NOTE: If a fish has been filleted, but the fish rack is available, do not obtain a length measurement.** Doing so creates a bias in the length measurement because if the

## Chapter 7. The Finfish Intercept Interview

fish were intact, the length would be different due to the girth of the fish. When the fish is filleted, the fish is flatter—causing a bias in the length measurement.

If length or weight is missing for all fish of a species, fill in the boxes for the missing data with “9.” **Missing data should be footnoted with an explanation.** Acceptable reasons for not obtaining weight or length measurements include:

- ✓ Angler refused to let you weigh or measure his/her fish.
- ✓ You were unable to obtain a weight because the fish was gutted.
- ✓ You were unable to obtain a weight because the weight exceeded the capacity of your large scale.

If length and/or weight information are missing for some fish of a species (i.e., the angler refused to have the appropriate number weighed and measured), you should fill in the available weights and lengths using separate “Type 3” records. **You should then use a footnote to explain why some fish were not weighed and measured.**

If length and weight information is available for some fish of a species, do not complete extra lines with “9” as lengths and weights. For example, if you count and identify five black sea bass and obtained weights and lengths for only three of the five fish, complete three Type 3 lines. In each case, the “number of fish” should be listed as “005” even though you are only completing three lines. Do not add two extra lines with “9” for weights and lengths. If length and weight information are missing on all fish of a species, you should only fill out one “Type 3” record for the species. That record would have “9” in the length and weight boxes. Again, a reason for the missing data should be written on the form. You should never skip a record line on a coding form. The next fish should be entered on the next line.

### Example 1

\*31. AVAILABLE CATCH, COMPLETE TYPE 3 RECORD BY ASKING: May I look at your fish? What do you plan to do with the **MAJORITY** of the species.

TYPE 3 RECORDS	SPECIES CODE	# OF FISH	LENGTH (mm)	WEIGHT (kg)	DISP
1 black sea bass	167687	005	0323	001	203
2			0417	001	80
3			0392	001	70
4					
5					
6					
7					
8					

other two fish were already filleted

## Chapter 7. The Finfish Intercept Interview

### Example 2

\*31. AVAILABLE CATCH, COMPLETE TYPE 3 RECORD BY ASKING: May I look at your fish? What do you plan to do with the **MAJORITY** of the species.

TYPE 3 RECORDS	SPECIES CODE					# OF FISH		LENGTH (mm)				WEIGHT (kg)		DISP				
	1	6	7	6	8	7	0	1	2	9	9	9	9		9	9	9	9
1	black sea bass																	
2																		
3																		
4																		
5																		
6																		
7																		
8																		
9																		
10																		
11																		
12																		

*Handwritten notes on the form:*  
 Angler in a hurry didn't want me to measure fish (would only let me count them)

**NOTE:** If an angler allows you to identify and count his/her catch, but refuses to allow you to weigh/measure the catch, the interview is still good as long as the angler answered all key items. If all key and non-key items were obtained, it is still considered a Status 1 interview.

The disposition codes for the Type 3 records are listed under Item 25 (with the exception of disposition codes 1 and 2, which can only be used for Type 2 fish). The question to be asked is: "What do you plan to do with the majority of the (species name)?" **Since only one disposition can be used for each species under Item 31, it is important that you ask what the angler plans to do with the majority of fish for each species.** For example, if an angler has caught three fish of the same species, and he/she intends to sell the largest one and eat the two smaller ones, then you should code all records with disposition as "3 - Eaten/Plan to eat." This is because more fish will be eaten than sold.

When there are equal numbers of fish that have two or more disposition codes, then use the weight to determine the correct disposition code. For example, if there are exactly two fish of one species, one of which will be sold and one of which will be eaten, code to the disposition of the *heavier fish*.

Eighteen Type 3 records can be entered on each Intercept Form. If more than 18 are needed, use the second page of a clean Intercept Form, fill out Items 2 through 10 using the same information from the first form and **clip, not staple**, that form to the original form. In some instances, several second pages may be needed. As with Type 2 records, please mark each page as "page 1 of 2," etc.

**Item 32-Saltwater angler license?** – Anglers are asked whether they have a license which allows them to harvest saltwater fish in the state of North Carolina. Note: anglers covered under blanket licenses (piers, charter or headboats) do not need a license to fish. **We are not an enforcement authority and do not issue tickets or report unlicensed anglers to Marine Patrol.**

## **Chapter 7. The Finfish Intercept Interview**

---

\*32 Do you have a license that allows you to harvest saltwater fish in this state? 1. YES 2. NO 3. Lifetime (If yes ask Q33)

*Item 33-License purchase date?* – If an angler has a license record the month and date of purchase. If they do not remember check “Don’t Know”.

\*33 When did you purchase your current license (enter mm/yy) Month \_\_\_\_\_ Year \_\_\_\_\_ Don't know \_\_\_\_\_

# CHAPTER 8. CONDUCTING THE CREEL CENSUS

## Fish Identification

You must strive to identify all available fish (Type 3) to the species-level. In the interest of professionalism, never ask the angler to identify his/her own available catch. For unavailable fish, including fish that have been filleted, ask the angler to identify his/her catch. You will be expected to use your local knowledge to assist the angler in identifying his/her catch. Use your *Peterson's Field Guide to Atlantic Coast Fishes* to assist the angler with this identification, but remember not to use leading questions. Do not force an angler to pick a species if they are not sure about the identification.

Accepted common names are not necessarily those used by local anglers, and you should know how to translate local names into accepted common names. Please refer to your Intercept Coding Manual for a complete species list, listed alphabetically. The Intercept Coding Manual also contains a list of local names and how they often translate into accepted common names. It also has additional descriptive information on species that are often difficult or confusing to identify. Do not neglect this as a valuable tool in achieving correct identifications.

As a last resort, if you are still unable to identify the fish, it must be coded as a Type 2 record (under Item 25). Please keep in mind that a fish not identified to the species-level CANNOT be recorded under Item 31 (which is for Type 3 records only). If you cannot identify a Type 3 fish to the species-level, make notations on the Intercept Form, including any distinguishing features about the fish—and, if possible, take a picture of the fish. When your interviewing day is completed, or if there is a break in the day when no one is available to interview, contact your field supervisor. Explain to what level you were able to identify the fish and provide any distinguishing features.

Even for Type 2 fish, you must identify fish as close to the species-level as possible. *Peterson's Field Guide to Atlantic Coast Fishes* is the recommended field guide. However, other local references and taxonomic keys approved by NOAA Fisheries may also be used. Please call your supervisor if you have any questions regarding the use of additional resources.

Please keep in mind that the species code lists in your Intercept Coding Manual are not exhaustive. You may occasionally identify a species that does not appear on the list. When this situation occurs, write out the scientific and accepted common name of the species and leave the coding boxes blank. Write a detailed description of the fish, how you were able to identify it, distinguishing characteristics etc. You must explain how the species was confirmed. If possible, take a picture of the fish so that the staff marine biologists can confirm its identity. If you are unable to clearly identify a fish, use Figure 8.1 to note key characteristics of the fish's anatomy. Examples of this are spots on the caudal peduncle, location of fins, lack of fins, shapes of fins, size of eyes, etc. Note water depth and location caught if possible.

## Length Measurements

## Chapter 8. Conducting the Creel Census

---

Fork length is recorded for all fish. **Fork length is the length of the fish from the tip of the snout to the fork of the tail** (Figure 8.2). Note that this figure also illustrates the different types of tails and snouts.

**Figure 8.1: Anatomy of a Fish**

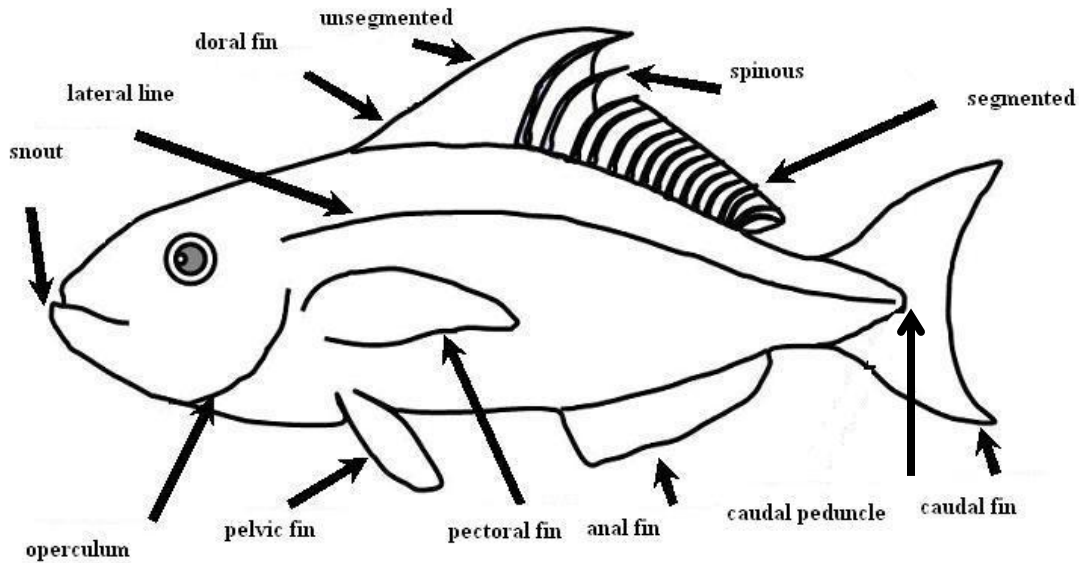

**Figure 8.2: Measuring Various Fish**

The correct procedures for measuring the various types of fish found on the Atlantic Coast are as follows:

Sharks and sturgeons are measured from the tip of the snout to the center of the fork of the tail.

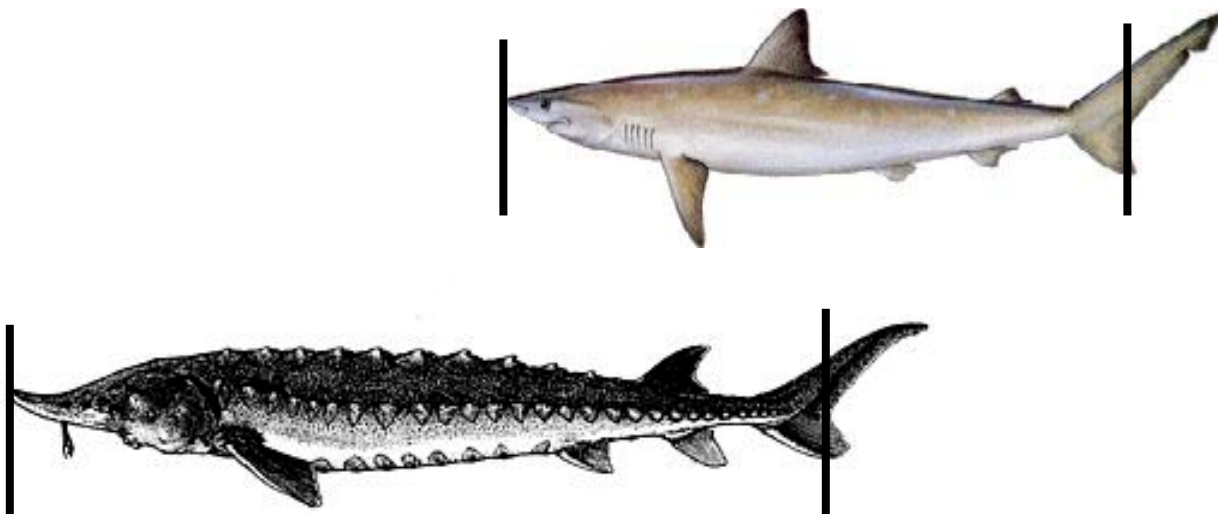

## Chapter 8. Conducting the Creel Census

---

Skates and rays are measured from the tip of the snout to the distal end of the pelvic fins. Do not include claspers.

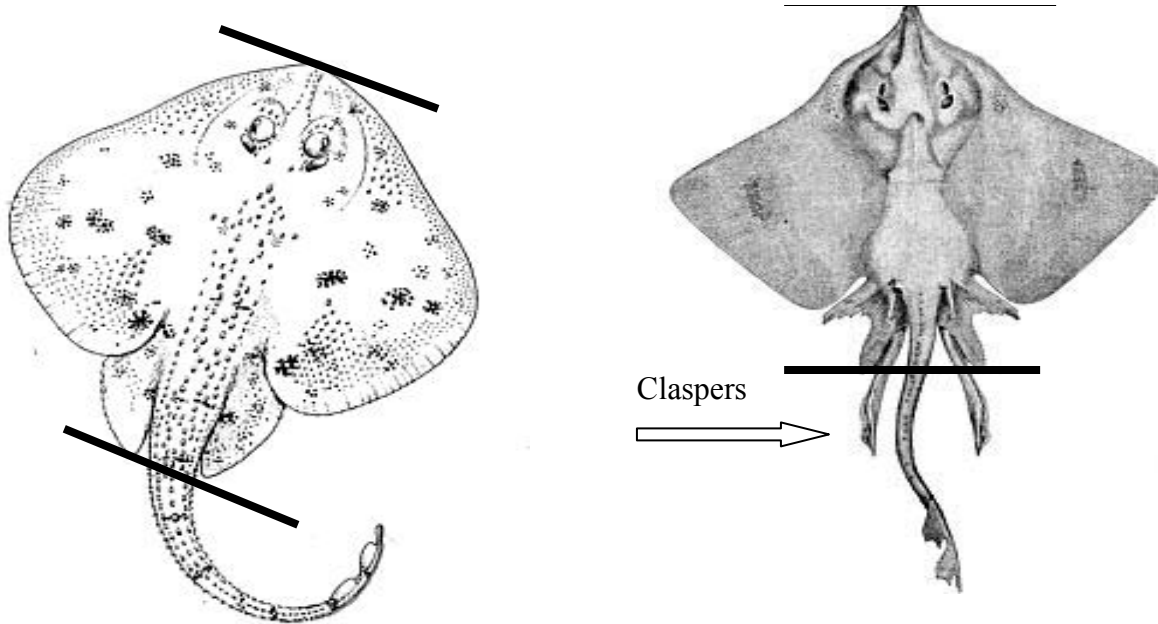

Swordfish and billfish are measured from the tip of the lower jaw to the center of the fork of the tail.

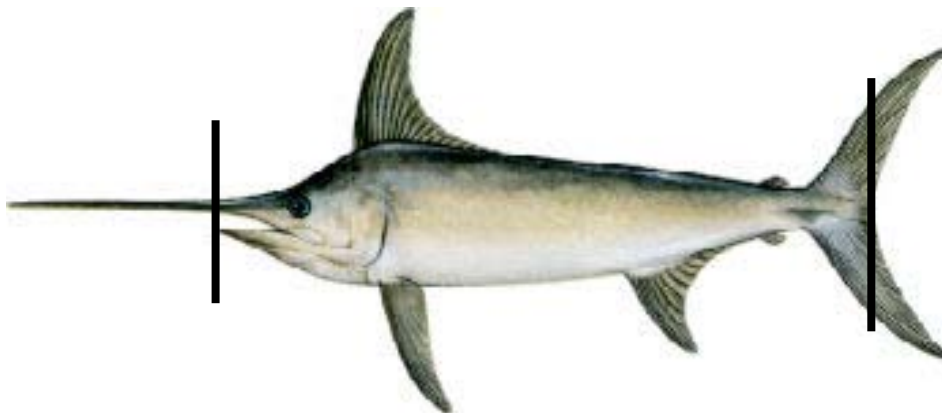

## Chapter 8. Conducting the Creel Census

---

Black sea bass are measured from the tip of the snout to the centerline of the tail. Although this is neither the longest, nor the shortest length measurement, it is the most consistent.

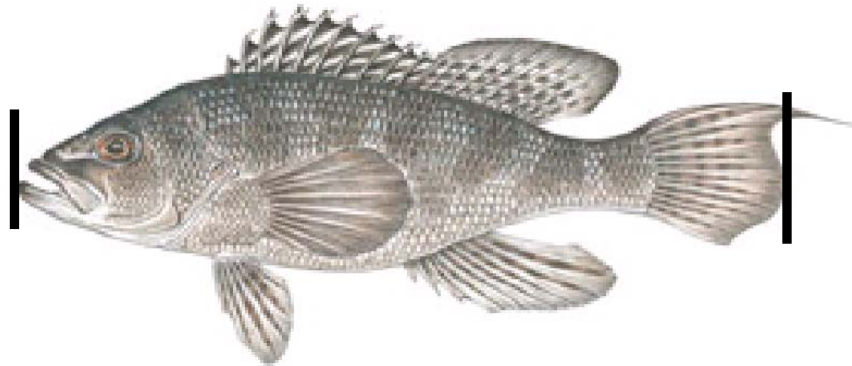

All other species are measured from the anterior tip of the longest jaw to the tail. This procedure is the same whether the tail is forked (e.g. bluefish) or protrudes out (e.g. flounders). The resulting length is therefore a fork length. Refer to examples below.

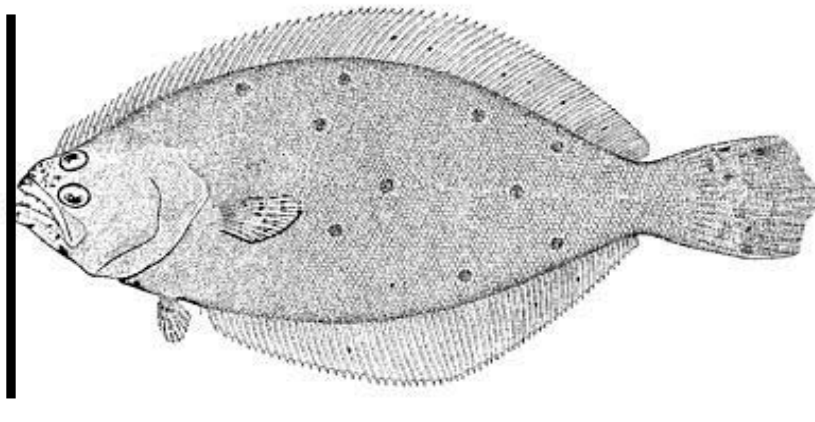
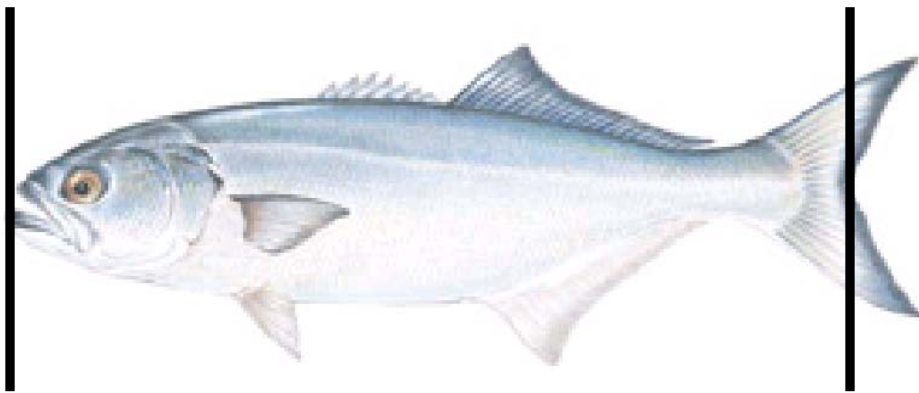



## Chapter 8. Conducting the Creel Census

---

### Length Measurements

Fish lengths must be taken using a measuring board and recorded to the nearest millimeter. The measuring board provided to you is labeled in centimeters. To determine millimeters, multiply the centimeter reading by 10, and add the number of smaller markings past the centimeter marking. Contact project staff immediately if you have any trouble reading or interpreting the measurements on your board.

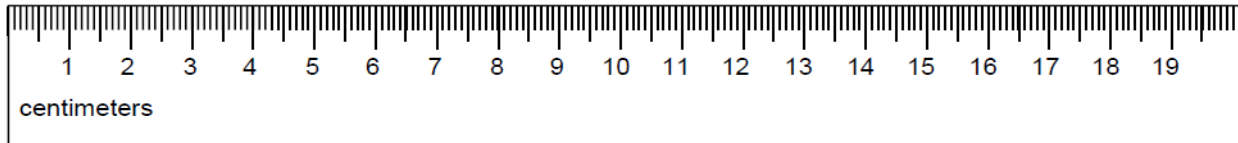

For example, a fish that measures to the first line past "23" is "231" millimeters. Since four coding boxes are provided for the length measurement, the length of this fish should be coded as "0231." **Never round lengths to the nearest centimeter or half centimeter.** Rounding fish measurements will introduce a "digit bias." An example of proper use of a measuring board is provided in Figure 8.3.

You will also be issued a tape measure to be used IN ADDITION to the measuring board. A fish that exceeds the length of the measuring board should be placed on the measuring board using the same procedure as explained above. The tape measure should be placed UNDER the portion of the fish that extends past the board, being sure that the edge of the tape measure is flush with the end of the board. Read the length to the nearest millimeter on the tape measure. Add that measurement to 1,000 millimeters (the total length of your measuring board) to obtain the total length of the fish. At no time should you hold the tape measure above a fish; this will result in an inaccurate length measurement if the tape measure bends to the contour of the fish's body.

### Figure 8.3: Length Measurements

#### Proper Use of the Meter Measuring Board

- 1) Place the measuring board on a hard level surface. You will need both hands free.
- 2) Place the fish with the anterior most portion of the head (the nose) flush against the upright edge on the left end of the board. The specimen should be positioned over the metric scale.

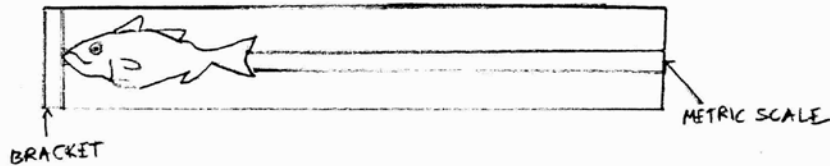

- 3) Keeping the nose of the fish against the edge, press the caudal fin (tail) with the forefinger of the right hand down to the surface of the board.

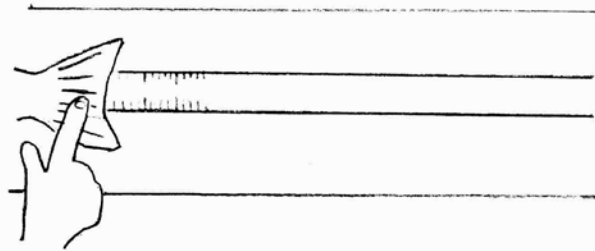

- 4) Read the length to the nearest millimeter (mm) at the fork of the caudal fin.

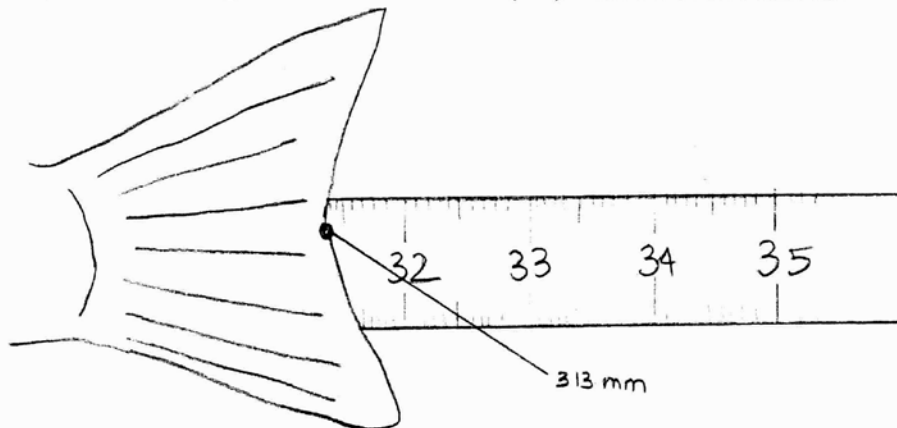

### Weight Measurements

We provide two scales to you—a large scale (12.5 kg) and a small one (2 kg). The larger scale should only be used for fish weighing more than the weight capacity of the smaller scale. Fish weights have to be recorded to the nearest five one-hundredth (0.05) of a kilogram when the smaller scale is used, and the nearest tenth (0.10) of a kilogram when the larger scale is used. Five boxes have been provided for the coding of weight: three to the left of the decimal, and two to the right of the decimal. For example, a fish weighing

## Chapter 8. Conducting the Creel Census

---

4.4 kilograms on the larger scale should be coded as "004.40," and a fish weighing 0.15 kilograms on the smaller, more precise scale should be coded as "000.15."

Weight measurements should be given priority over length measurements when time is limited.

When weighing fish, always take your readings from the metric side, and not in pounds. Anglers will often want to know how much their fish weigh in pounds. If the angler asks, record the weights of your fish in kilograms on your data sheet first. After you have completed the interview, you can then weigh fish for the angler in pounds.

### Calibration and Use of Chatillon Scales

While scales should be calibrated at least once or twice a year using a set of certified standard weights, you should also prepare for every assignment by ensuring that your scales are zeroed properly. Most instances of improper zeroing result in rather small errors of between 0.1 to 0.2 kg. This amount may seem insignificant, but when catch estimates are expanded from raw data, these "small" errors can cause a large, undesirable weight bias. For example, suppose you frequently encounter a small species of fish which rarely exceeds weights of 0.2 kg. If a scale is not set properly, and reads 0.1 kg light, then you would be under-reporting the biomass of those fish by as much as one-half the actual value. Of course, the more out of adjustment the scale, the more significant the error becomes. It is important that you realize that even apparently minute maladjustments can cause bias. Figure 8.4 shows how to properly calibrate Chatillon spring scales.

**Note:** The definition of calibrating a scale is to weigh an object of a known weight to be sure that the scale is taking an accurate measurement of the object. When "zeroing" a scale, twist the screw on the top to level it out so that "0" is indicated on the scale before weighing an object.

## Chapter 8. Conducting the Creel Census

---

Figure 8.4 Calibration of Chatillon Scales

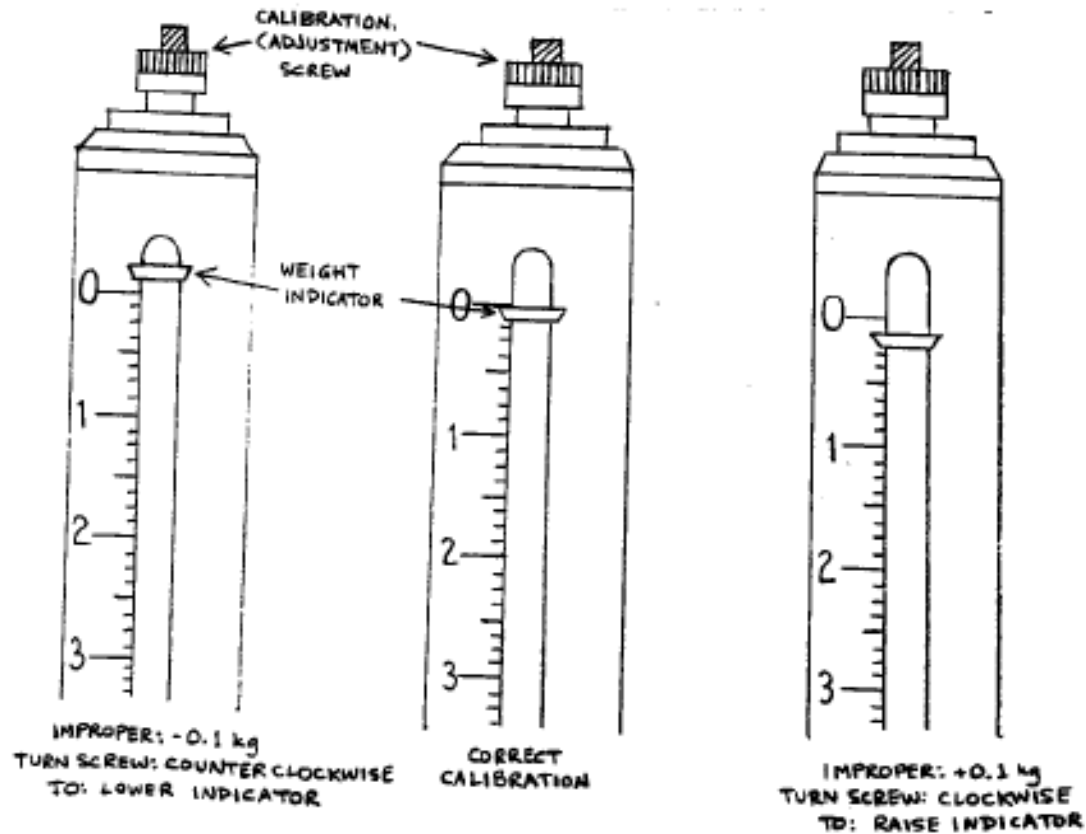

Over time, springs inside the scales may stretch and measure inaccurately. If you feel your scale(s) is weighing improperly, find an object of known weight (preferably a standard weight, but a meat or deli package with the actual weight marked on it and minimal packaging would also work), and test it on the instrument to see if it conforms to the expected weight. If it does not, then do not use that scale and contact your field supervisor for a new, verified unit as soon as possible.

If you do not have an object of a known weight, or if you have any concerns about your scales, please call your field supervisor immediately!

You are required to return your scales to the main office at least once per year to allow staff to calibrate them using highly accurate calibration equipment. We will be happy to issue new scales to you while we check the quality of yours.

## **Chapter 8. Conducting the Creel Census**

---

The following rules apply when you are in the field:

- ✓ Always carry both scales (2 kg and 12.5 kg) with you since you never know the size of the fish you will encounter.
- ✓ The 2 kg scales have graduations of 0.05 kilograms. Readings should be taken to the nearest 0.05 kilograms (e.g. 0.20 kg, 0.25 kg, 1.35 kg, 1.40 kg, etc.).
- ✓ The 12.5 kg scales have graduations of 0.10 kilograms. Readings should be taken to the nearest 0.10 kilograms (e.g. 4.10 kg, 5.70 kg, 9.00 kg, etc.).
- ✓ Always make sure the scale reading is set at zero before weighing any fish. If the scale is not zeroed, do so by adjusting the calibration screw at the top of the scale. If you cannot accurately zero your scale, it may be defective.

In the past, occasions have occurred when interviewers inadvertently measured in pounds rather than in kilograms. To avoid this, we have painted over the pound-side of the scale with red nail polish or paint. This will be checked at QC visits and during local wave meetings.

If at any time you have reason to believe that your spring scale is not functioning properly, contact your field supervisor immediately.

Always keep in mind: accuracy is the key to our scientific integrity!

### **Care of the Chatillon Scales**

You are expected to take good care of your scales. These scales are expensive, and it is critical to the success of this survey that all interviewers have accurate scales every time they are in the field. Please call your field supervisor if you have any questions about the required care items listed below:

- ✓ Keep your scales protected in sealed, dry, clean zip-lock bags when not in use.
- ✓ Never store your scales by hanging them from the weighing hook as this will stretch the spring.
- ✓ Avoid contact with saltwater if possible, and never leave scales in a puddle or bucket of water. If your scales do come in contact with saltwater, rinse with freshwater, and allow them to dry thoroughly before storing in the zip-lock bag.
- ✓ Always make sure the scale reading is set at zero before weighing any fish. If a scale is not zeroed, do so by adjusting the calibration screw at top of scale. If you cannot adequately zero your scale, it may be defective.
- ✓ When you receive your scales, spray them with any all-purpose, anti-corrosive grease (e.g., WD40) for extra protection. This should be repeated every day you use your scales. It's a cheap investment that will prolong the life of your scales.

### **Sub-Sampling Procedure**

When an angler has more than 10 fish of the same species available for inspection, a sub-sample of 10 fish must be selected for weight and length measurements. You will be issued one random numbers table every month, along with your assignment schedule.

## Chapter 8. Conducting the Creel Census

---

You will use this random numbers table to select fish for measurements. If the angler has more than 10 fish but less than 20 fish of one species, you will use the table to **exclude** fish; if the angler has more than 20 fish, you will use the table to **include** fish (think: **increased** number of fish? Use the table to **include**!). Regardless of whether you need to exclude or include fish for measuring, you will:

- ✓ **Always** use the random numbers table
- ✓ **Never** visually select the fish
- ✓ **Never** measure only the largest or smallest fish
- ✓ **Never** select 10 fish of “average” size
- ✓ **Never** let the angler dictate which fish are included or excluded
- ✓ **Always** write notes on the intercept form to explain any missing measurements

### Using the table to exclude fish

When the total number of available fish is 20 or fewer per species per angler, you will need to measure 10 (per species, per angler) and so will use the random numbers table to identify the fish that will **not** be measured. Since the count is conducted first, as you remove each fish from the angler’s ice chest you place the fish vertically on the measuring board until all fish are placed on the board (all facing away from you, or “up”). Then use the random numbers table to exclude individual fish until you have 10 fish remaining; those remaining fish are the ones that you would measure.

**Example 1:** You are interviewing one angler who has kept 19 scup. Following the procedures above, you lay the fish on your measuring board all facing “up”. Since you only need to measure 10 of those fish, you need to exclude 9 fish, and will use the random numbers table to do so. Since there are 19 fish in this example, you will ignore all numbers higher than that, though you will still cross them off.

Since the first number in the table is 19, you need to exclude the 19<sup>th</sup> fish and do so by turning the fish around to face the other direction (toward you), and cross off “19” in the table. The next number in the table is 12, so you turn fish number 12 to face in the other direction, and cross off “12” in the list. You continue with this method, crossing off fish number 1 and fish number 15. The next number in the table is 19, but that fish has already been excluded, so you would cross off 19 and move to the next number. Since the next number (01) has also already been used you would cross that off and move to the next number which is 20. Since that number is more than the number of fish available, you would cross that off and move to the next number. Continuing with this method, the final result is that fish numbers 1, 3, 4, 10, 11, 12, 15, 16, and 19 would be excluded, and fish numbers 2, 5, 6, 7, 8, 9, 13, 14, 17, and 18 would be included (measured). For the next interviewed angler with fish, you would start the process over, beginning with the next number in the table (02).

## Chapter 8. Conducting the Creel Census

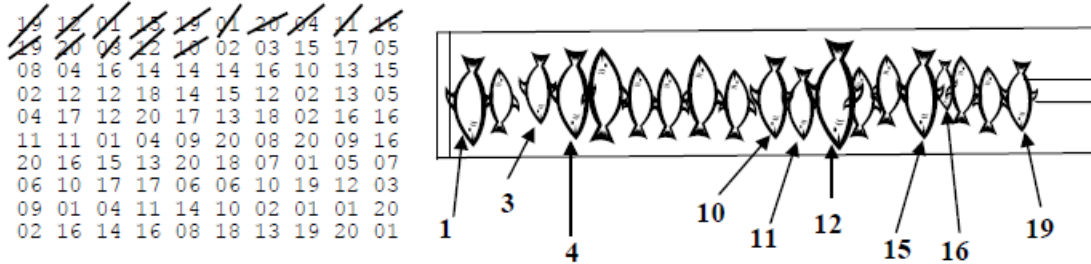

### Using the table to include fish

When the total number of available fish is more than 20 fish (*per species, per angler*) you will need to use the random numbers table to **include** fish since more often than not the fish will not all fit on the measuring board.

**Example 1:** You are interviewing one angler who estimates that he kept 35 or 40 scup. You will only measure 10 of those fish, and will use the random numbers table to determine the starting point. For simplicity, you will ignore all numbers in the table that are higher than 10 (though you will still cross them off).

Since you won't know the exact total until you count the fish, use the lower number the angler provided you (35) and divide by ten, and then round down to the next whole number which in this example is 3 ( $35/10 = 3.5$  which rounds down to 3). This means that you will measure every 3<sup>rd</sup> fish.

Since you still need to determine the starting point, you refer to the random numbers table. (Remember to ignore numbers greater than 10). The next number in the table that fits this criterion is 02, so you'll need to start measuring with the 2<sup>nd</sup> fish. Transferring the angler's fish to your bucket while you're counting, you put the 2<sup>nd</sup> fish on your measuring board (to measure when you're done counting). Continuing with the count, you then put fish numbers 5, 8, 11, 14, 17, 20, 23, 26, and 29 on your board, and then measure and weigh all ten.

<del>19</del>	<del>12</del>	<del>01</del>	<del>15</del>	<del>19</del>	<del>01</del>	<del>20</del>	<del>04</del>	<del>11</del>	<del>16</del>
29	20	08	22	18	02	03	15	17	05
08	04	16	14	14	14	16	10	13	15
02	12	12	18	14	15	12	02	13	05
04	17	12	20	17	13	18	02	16	16
11	11	01	04	09	20	08	20	09	16
20	16	15	13	20	18	07	01	05	07
06	10	17	17	06	06	10	19	12	03
09	01	04	11	14	10	02	01	01	20
02	16	14	16	08	18	13	19	20	01

## Chapter 8. Conducting the Creel Census

---

**Example 2:** You are interviewing five anglers from a charter boat. They estimate they've kept about 150 Atlantic mackerel (everyone's catch has been grouped together). Since you need to measure and weigh 10 fish per person, per species, you'll need to measure 50 fish for this group of anglers. To figure out the interval you'll need to divide the total number of fish by the number you need to measure ( $150/50 = 3$ ), so you'll measure every 3<sup>rd</sup> fish.

The next number in the random numbers table is 03, so that will be the first fish you measure. Since you need to measure every 3<sup>rd</sup> fish, you'll also need to measure fish 6, 9, 12, 15, 18, 21, 24 ... 138, 141, 144, and 147. You stop with 147 because the actual total count was 148. If the total number of fish had actually been 150, you would measure fish number 150 as well.

```
19 12 01 13 19 01 20 04 11 16  
19 20 03 12 18 02 03 15 17 05  
08 04 16 14 14 14 16 10 13 15  
02 12 12 18 14 15 12 02 13 05  
04 17 12 20 17 13 18 02 16 16  
11 11 01 04 09 20 08 20 09 16  
20 16 15 13 20 18 07 01 05 07  
06 10 17 17 06 06 10 19 12 03  
09 01 04 11 14 10 02 01 01 20  
02 16 14 16 08 18 13 19 20 01
```

### Sub-sampling alternative for Private/Rental boat mode

This method only applies to private/rental mode in situations where the angler is willing to allow fish to be removed from their ice chest for counting and measuring but there is insufficient room to do so as described in previous examples. It is very important not to inconvenience the angling public. Most anglers will let you know if they have their fish packed in ice in such a way that they do not want you to disturb them. In some situations anglers may be willing for you to measure their fish but there may not be a suitable location (e.g., measuring board too small for previous sub-sampling methods). The anglers will likely not want you to lay fish out on the deck of their boat.

If due to time and space limitations when sampling in private/rental mode it is not possible to line up the fish, you should first count all the fish. Ideally, fish are counted as they are removed from the ice chest and placed in a bucket. As you are returning the fish to the ice chest, select every *n*th fish for length and weight measurement. The selected fish for measuring and weighing should be placed in a second bucket (or ideally a second ice chest) and the remainder returned to the angler's ice chest packed in a manner they were first observed. If the angler's ice chest is sufficiently large you may move or "bunch" the fish to one side of the ice chest then select every *n*th fish as you count the fish moving them to the opposite side of the ice chest.

To determine which fish are selected for measurement when there are more than 20 fish per species per angler use the same procedure as described in example 2 above by



## **Chapter 8. Conducting the Creel Census**

---

dividing the total number of fish available by the number of fish needed for measurement (number of anglers times 10). In situations where there are less than 20 fish per species per angler, select the first or last ten individuals counted.

# CHAPTER 9. ADMINISTRATIVE FORMS

## Non-Disclosure Form

For each new hire, we require a great deal of paperwork and forms to be filled out. One of the most important documents in the new hire packet is the NOAA Administrative Order regarding the protection of confidential fishery statistics, along with the signature page acknowledging your receipt and understanding of the policies. This is appropriately named “Appendix M NOAA Administrative Order 216-100.”

The purpose of this order is to prescribe policies and procedures for protecting the confidentiality of data submitted to and collected by NOAA Fisheries as authorized or required by law. It informs authorized users of their obligations for maintaining the confidentiality of data received by NMFS; provides for operational safeguards to maintain the security of data; and states the penalties provided by law for disclosure of confidential data.

Authorized users are field personnel who collect survey data from anglers and captains.

As an authorized user, you are expected to maintain all documents containing all survey data in a secure place at all times. You are not allowed to disclose any portion of this data with anyone that is not authorized to see it. You are not allowed to show the completed forms to anyone except DMF staff or the NOAA Fisheries Headquarters office. You are not allowed to disclose **any** of the information you collect in any manner, whether it be verbally or in written form. If you violate this agreement you are signing, then we maintain the policy of immediate termination for violation of the non-disclosure agreement. In addition, NMFS maintains the right to pursue the matter legally with you as an individual, as well as with DMF. There is also no statute of limitations on this agreement. This means that you will never be permitted to discuss any information with anyone other than NMFS or DMF even after your employment with the company has ended. If this agreement is violated, NMFS could still prosecute for violation of the non-disclosure agreement.

Certain questions may arise when you are approached by anglers, or other members of the community. We have listed a few of the most frequently asked questions; if you have any other questions, please don't hesitate to call project staff for clarification.

### 1) What Questions *Should* I Answer?

As a trained field interviewer, you should be able to answer basic questions about the survey with confidence. These questions include: “Who are you?” “Why are you interviewing me?” “How will my answers be used?” The “To Whom” letter and brochure are also important resources to distribute to anglers or members of the public who have questions about the survey. When in doubt, it is *always* better to say that you do not know the answer and that you will get back to the person, than to share potentially false or incomplete information.

## Chapter 9. Administrative Forms

---

### 2) What Questions Should I *NOT* Answer?

You should *not* answer questions about survey methodology, statistics, or estimates. You are not trained to respond to questions about how the sample draw works, how we assign and use pressures at different sites, how the estimates are created, etc. These questions should only be addressed by someone from NMFS. We want to make sure that you are not put in a position of answering detailed questions that you have not been trained to address. Even if you answer such questions with the intent of being helpful, the information may be taken out of context and used to discredit the survey and NMFS. For example, if an angler asks you, “So how many fish do you think are really out there, from all the information that you collect, you could probably figure out what regulations should really be.” Your answer should be, “I was not trained to analyze the data, just to collect it. If you refer to information on the NMFS website, it might be able to answer your questions.” You should also provide the angler with the state brochure and web card. Under no circumstances should it appear that you are avoiding their questions, but that you are directing them to a more appropriate source.

Anglers will sometimes ask about the success of other anglers fishing in the area, or in what areas the fish are biting. In these cases, it is best to provide a vague response, such as “here and there” or “it’s been mixed” or “I’ve talked with so many people today I really don’t remember”.

Anglers may also ask about the fishing success of particular head boats or charter boats, or which boats give more “bang for the buck”, or even which boat you recommend since you may have interviewed anglers from several different boats. An appropriate response to these types of questions would be to say that there are many different fishing message boards and other websites where they could obtain that information. If the person persists in their questioning, you should tell them that that information is confidential. Remember, your job is to collect the data, not to provide reviews (positive OR negative) about particular businesses.

### 3) What Should I Do If Someone Asks Me A Question I Should Not Answer?

If anyone has specific questions about the survey, you should explain that you are not the best person to respond. Ask the angler if he/she would like someone to get back to him/her with an answer. It is very important that you respond in a helpful and positive manner; this does NOT mean that you have to answer the question. NMFS wants the public to learn about and understand the survey—and they have the resources to address complicated questions. Do not avoid such questions in any way, but rather, make it clear that we want the public to have the best information possible. Assure the angler that someone else will get back to him or her very soon.

Take down the person’s name and number and give it to DMF staff—who in turn will pass on the information. The information will then be shared with NOAA Fisheries, and they will make sure that someone contacts the person to answer his/her questions.

For example: If an angler is asking multiple questions about the survey and the role it plays in regulations, you should reiterate that you just collect the data, then ask him or her

## Chapter 9. Administrative Forms

---

to write down contact information for you and you will contact PROJECT STAFF immediately and pass along his/her concerns. The contact information will be forwarded to NOAA Fisheries.

### **4) What Information Should I Never Share?**

You should NEVER disclose information about specific catch or catch locations that you observe as a field interviewer. Doing so *violates the non-disclosure agreement that you sign as a condition of employment*. There can be very serious legal repercussions for you and for DMF if any confidential information is shared with anyone outside the company. In addition, interviewers who release confidential information to anyone in any forum (in-person, on a website, etc.) will be terminated. An example of this is if someone came up to you and said, "Hey I heard you were out fishing on Bob's Head boat the other day, how did they do?" Your response should be: "I am sorry sir, but all of the information that I collect for the survey is completely confidential."

### **5) Where Do These Guidelines Apply?**

These guidelines pertain to questions you may be asked out in the field, on message boards, or *anywhere* else. Interviewers who choose to participate in online message boards need to be especially mindful of NOT providing any information that could (even unintentionally) negatively affect DMF, NMFS, or the survey. Therefore, if you choose to participate in online message boards, you are required to do so as a "private citizen," rather than as a field interviewer. Therefore, you should not identify yourself as a field interviewer. Any time that interviewers represent NOAA Fisheries, DMF, and the survey, we expect that their manner and language will be professional.

### **6) How Should I Handle Public Meetings?**

If you choose to attend public meetings where fisheries issues are discussed, you should do so only as a member of the public, and should never attempt to represent the survey. If you are recognized as an Atlantic Intercept Survey interviewer and questions about the survey are directed at you, explain that you are there only as a member of the public and not there to discuss or represent the survey, and refer the person to NOAA Fisheries. You should also report these questions to the DMF office, and we will have NOAA Fisheries get back to those people interested in the survey.

### **Returning DMF Equipment**

All field staff are provided with a 2 kg, 12.5 kg scale, a *Peterson's Field Guide*, fish measuring board, tape measure, hat, and badge when they are hired. If for any reason you are no longer going to be working on the project, you are required to contact the WARO office and request Fed-Ex supplies for the return of DMF's equipment. After employment is terminated, you are required to return your equipment to the WARO.

### CHAPTER 10. INTERVIEWING MATERIALS AND SUPPLIES

You will receive a copy of this manual, which will be updated annually. Upon successful completion of training, you will also receive the following materials:

- ✓ Assignment Summary Form (yellow form)
- ✓ Intercept forms
- ✓ To Whom Letter
- ✓ Privacy Act Letter
- ✓ Site Register
- ✓ Site Description forms
- ✓ Good and Bad Vessel Lists
- ✓ Peterson's Field Guide
- ✓ Scales (two sizes)
- ✓ Measuring Board
- ✓ Tape Measure
- ✓ Name Badge
- ✓ DMF hat
- ✓ Coding Manual
- ✓ GPS unit, if applicable

**NOTE:** It is your responsibility to review these lists of required equipment/supplies, and to request additional equipment/supplies when necessary.

You are allowed to purchase a road map of your area and tide tables if these are needed. These are reimbursable expenses, provided receipts are submitted. **Please call your field supervisor for approval before purchasing maps and/or tables in excess of \$10 each.**

### Bi-Monthly Interviewing Materials and Supplies

Prior to each wave of interviewing, you will receive the following:

- ✓ **Site Assignment List**—A listing of all your assignments for each month of the wave.
- ✓ **Site Register**—A list of all known salt water fishing sites in the state. This register is updated every wave. **DO NOT** use old copies of the Site Register!
- ✓ **Vessel Directory Good List**—A list of the for-hire vessels (charter and head boats) in your state for use in answering Box E on the Atlantic Intercept form.
- ✓ **All paperwork required to complete the issued assignments**—Please keep in mind that you may need to request additional paperwork!
- ✓ **Postage-paid return envelopes**—Please use these envelopes to return each completed assignment weekly.
- ✓ **FedEx supplies if you have assignments during the last four days of the month**—You will need to use the provided FedEx supplies to submit assignments completed during the last four days of each month. Please send ALL assignments completed during these four days in ONE FedEx package.

### **Materials You Need To Return With Each Completed Assignment**

**The following must be returned for each completed assignment** in a postage-paid business reply envelope (or via FedEx if during the last four days of each month). Depending on work that is done, this checklist will vary slightly. Please **DO NOT STAPLE OR FOLD THE FORMS!**

- ✓ Assignment Summary Form (yellow),
- ✓ Site Description form for each site visited,
- ✓ 1 intercept for each interview, and
- ✓ No paper clips, binder clips, rubber bands or staples.

Quick editing comments:

- ✓ Make sure that all times on intercept forms are different (i.e. don't pre-fill times).
- ✓ Watch skip patterns!!
- ✓ All questions are to be filled in.
- ✓ Enter leading zeros.
- ✓ **COMMENTS! COMMENTS! COMMENTS!**
- ✓ Fat fish? Tell us!
- ✓ Weird fish? Tell us!
- ✓ Angry captain? Tell us!
- ✓ Skinny fish? Tell us!
- ✓ Huge numbers of fish? Tell us!

It is acceptable to submit more than one assignment in each envelope as long as each assignment has been put in the proper order.

Please call project staff if you have any questions about the materials you are required to submit with each completed assignment. **Failure to submit all the required paperwork could delay the processing of your time and expense forms.**

### **When Do I Need to Send In Completed Assignments?**

Ideally, you should mail the forms for each completed assignment on the day the assignment was completed. **You are required to send in your paperwork no less than**

**weekly.** We track the date of receipt for each assignment, and will use this information during your performance evaluations. Please keep in mind that penalties may apply for assignments sent in late, or for assignments sent in using a shipping method other than those specified. Repeated failure to return completed assignments on-time is sufficient grounds to terminate your employment. **We reserve the right to withhold pay for assignments received later than the 3<sup>rd</sup> of the month.**

### CHAPTER 11. QUICK TIPS

#### Quick Tips

Included is a list of basic general guidelines that you should refer to on at least a monthly basis. These are here for your benefit and if you have any questions, please call project staff for further information.

- ✓ Submit all paperwork weekly.
- ✓ FedEx any assignments that are completed within the last three days of the month.
- ✓ Thoroughly edit all your paperwork—five minutes are allowed for each intercept form.
- ✓ Always be properly dressed for each assignment (closed-toed shoes, name badge, shirt tucked in, and no inappropriate logo shirts).
- ✓ Attend two out of three local wave meetings each year.
- ✓ Use your Procedures and Coding manuals; they are there to help you.
- ✓ Return all calls and emails from project staff within 48 hours.
- ✓ Take care of your scales (don't hang by spring hook, keep clean, rinse with freshwater, WD-40).
- ✓ Submit weekly tally sheets weekly. This is critical in tracking our progress.
- ✓ Don't wait until last minute to call for extra supplies. Contact your field supervisor for more supplies.
- ✓ Watch skip patterns (Questions 12-13, 26-30) on the intercept form (read the instructions that appear after each question).
- ✓ Make sure all intercept forms have a different time. They should be in sequential order with the times reflecting when the interview ended. Do not pre-fill the forms.
- ✓ Send all timesheets and expense reports in on-time. Timesheets and expense forms must be faxed to Dan Weathers at 802-863-8984 or emailed to Kelly Fitzpatrick and Katie Semanek no later than 2 p.m. every other Thursday.
- ✓ Enter leading zeros for all lengths and weights of fish.
- ✓ Write clearly and legibly and always in pencil. The only time you need a pen is when completing your time and expense forms.
- ✓ Make lots of notes on your papers—it will save us both a call!
- ✓ Fillets go into Type 2 Catch unless identified from racks and then there should be a note.
- ✓ Record 9s for a fish weight/length ONLY if you are unable to obtain an actual length or weight (rather than recording 0s or slash lines through the boxes.) If you are able to obtain lengths and weights for three out of six fish, then you do not need to add an extra line for the 4<sup>th</sup>, 5<sup>th</sup> and 6<sup>th</sup> fish. Examples are shown below.

# Chapter 10.

\*31. AVAILABLE CATCH, COMPLETE TYPE 3 RECORD BY ASKING: May I look at your fish? What do you plan to do with the MAJORITY of the species.

TYPE 3 RECORDS	SPECIES CODE					# OF FISH		LENGTH (mm)			WEIGHT (kg)		DISP						
1 bluefin tuna	1	7	2	4	2	1	0	0	7	0	9	4	8	9	9	9	9	9	3
2																			
3																			
4																			
5																			
6																			
7																			
8																			
9																			
10																			
11																			
12																			
13																			
14																			
15																			

*anglers would only let me measure one*

\*31. AVAILABLE CATCH, COMPLETE TYPE 3 RECORD BY ASKING: May I look at your fish? What do you plan to do with the MAJORITY of the species.

TYPE 3 RECORDS	SPECIES CODE					# OF FISH		LENGTH (mm)			WEIGHT (kg)		DISP						
1 atlantic mackerel	1	7	2	4	1	4	0	0	3	0	3	2	2	0	0	1	7	5	3
2 ↓																			
3 spiny dogfish	1	6	0	6	1	7	0	0	4	0	7	2	3	9	9	9	9	9	4
4 ↓																			
5																			
6																			
7																			
8																			
9																			
10																			

*not enough time*



Appendix B  
Site Cluster Map

NC Site Register, PENDER County  
Mode: PR Day Type: WD Month: AUG Time Interval: 2AM-8AM



NC Site Register, PENDER County  
Mode: PR Day Type: WD Month: AUG Time Interval: 8AM-2PM



NC Site Register, PENDER County  
Mode: PR Day Type: WD Month: AUG Time Interval: 8AM-2PM  
Cluster: 1



NC Site Register, PENDER County  
Mode: PR Day Type: WD Month: AUG Time Interval: 8AM-2PM  
Cluster: 2



NC Site Register, PENDER County  
Mode: PR Day Type: WD Month: AUG Time Interval: 2PM-8PM



NC Site Register, PENDER County  
Mode: PR Day Type: WD Month: AUG Time Interval: 2PM-8PM  
Cluster: 1



NC Site Register, PENDER County  
Mode: PR Day Type: WD Month: AUG Time Interval: 2PM-8PM  
Cluster: 2

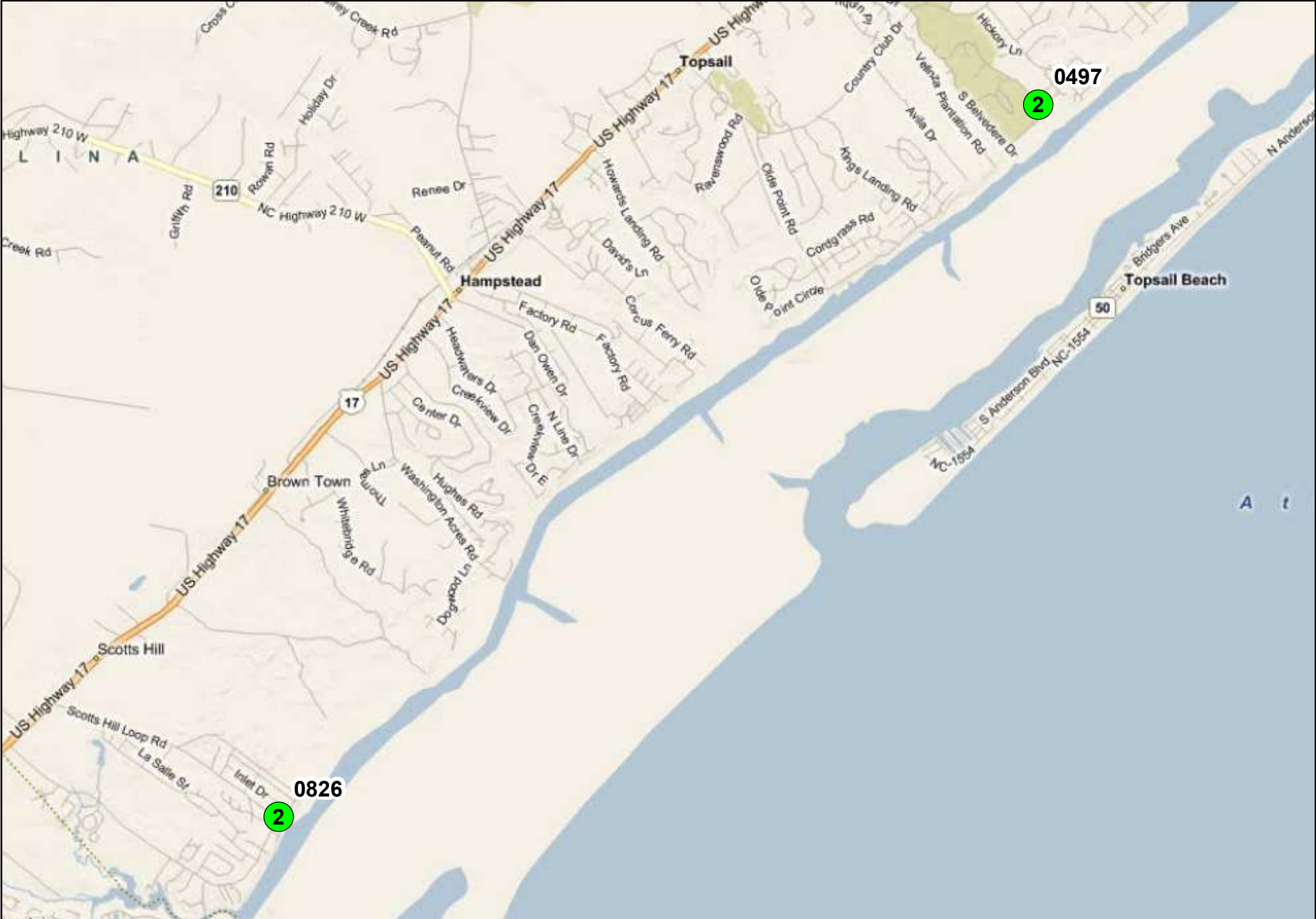



NC Site Register, PENDER County  
Mode: PR Day Type: WD Month: AUG Time Interval: 8PM-2AM



NC Site Register, PENDER County  
Mode: PR Day Type: WD Month: AUG Time Interval: 8PM-2AM  
Cluster: 1



NC Site Register, PENDER County  
Mode: PR Day Type: WE Month: AUG Time Interval: 2AM-8AM



NC Site Register, PENDER County  
Mode: PR Day Type: WE Month: AUG Time Interval: 8AM-2PM



NC Site Register, PENDER County  
Mode: PR Day Type: WE Month: AUG Time Interval: 8AM-2PM  
Cluster: 1

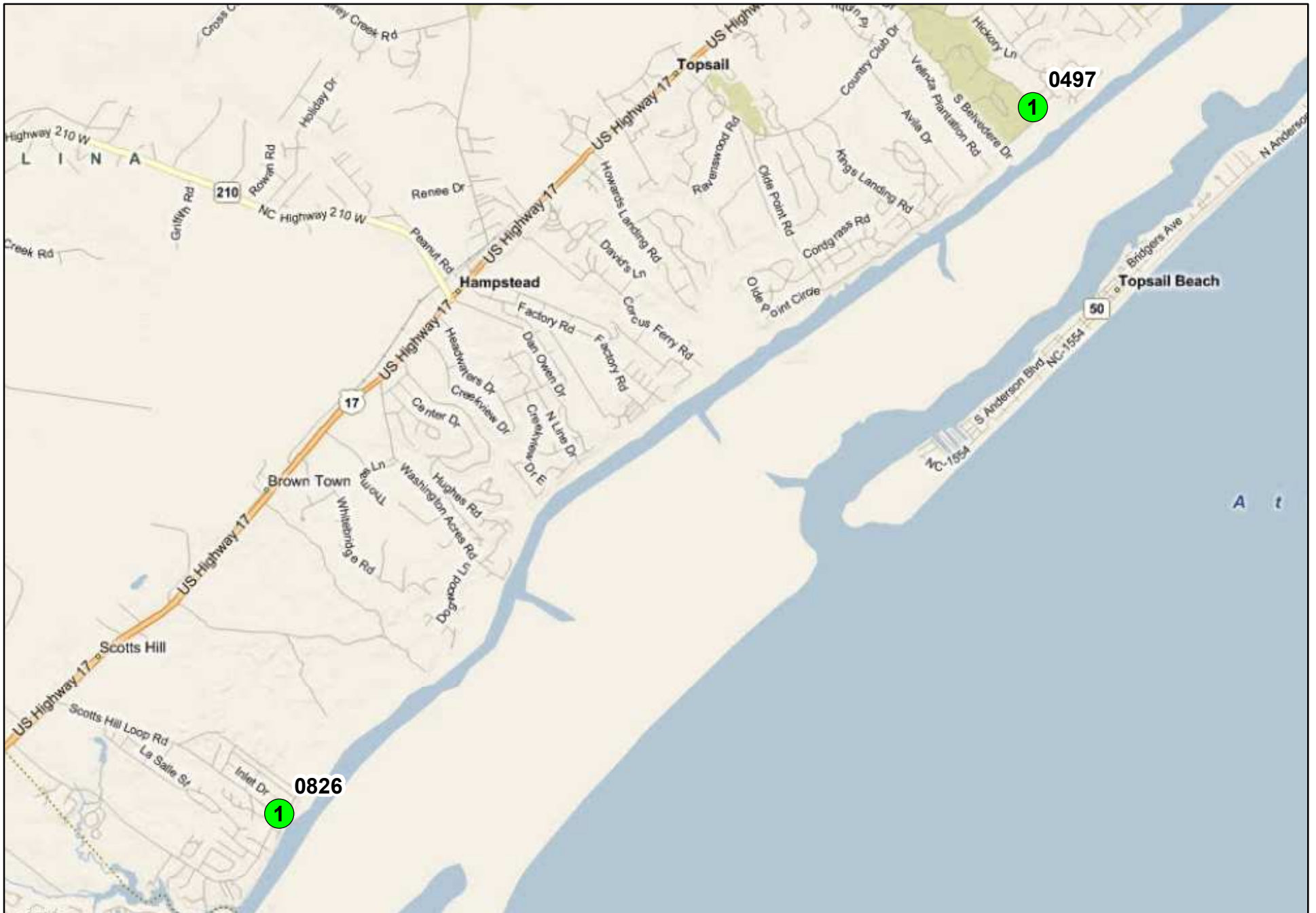

NC Site Register, PENDER County  
Mode: PR Day Type: WE Month: AUG Time Interval: 8AM-2PM  
Cluster: 2



NC Site Register, PENDER County  
Mode: PR Day Type: WE Month: AUG Time Interval: 2PM-8PM



NC Site Register, PENDER County  
Mode: PR Day Type: WE Month: AUG Time Interval: 2PM-8PM  
Cluster: 1





NC Site Register, PENDER County  
Mode: PR Day Type: WE Month: AUG Time Interval: 2PM-8PM  
Cluster: 2

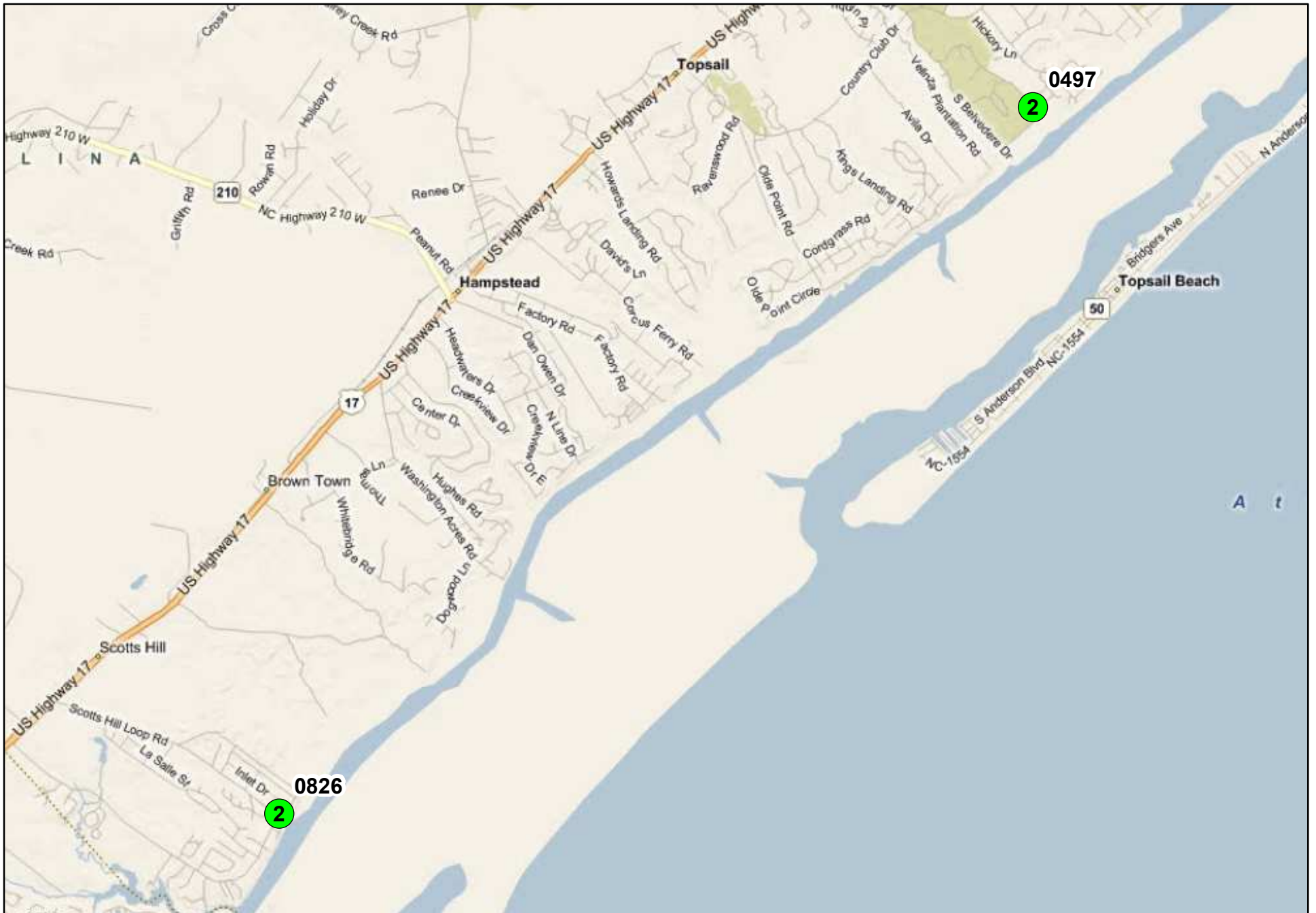

NC Site Register, PENDER County  
Mode: PR Day Type: WE Month: AUG Time Interval: 8PM-2AM

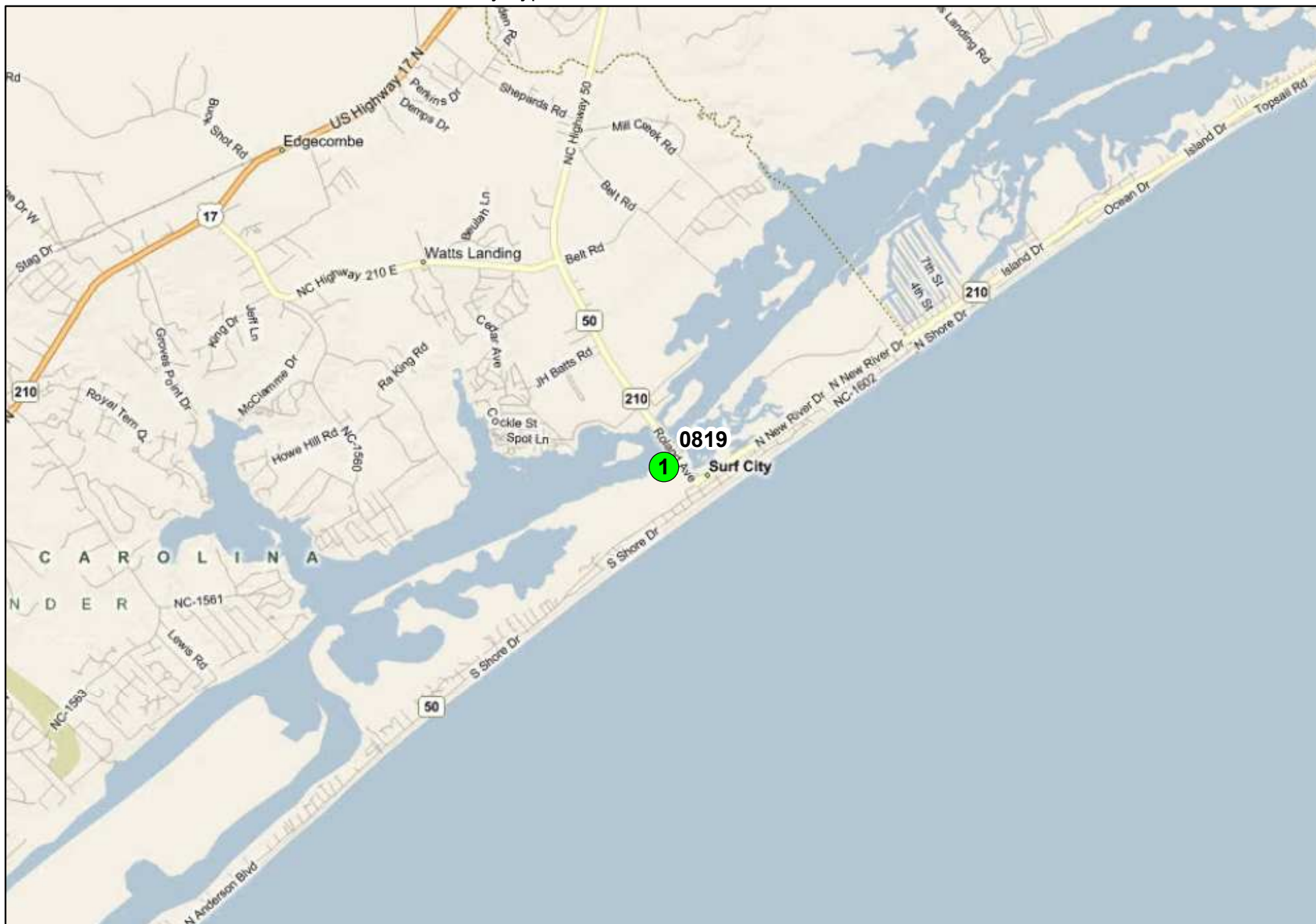

NC Site Register, PENDER County  
Mode: PR Day Type: WE Month: AUG Time Interval: 8PM-2AM  
Cluster: 1



Appendix C  
Assignment Summary Forms

## 2010 MRIP Assignment Summary Form

The Assignment Summary Form (ASF) is a standard form that's been in use since the beginning of the Marine Recreational Fisheries Statistics Survey (MRFSS). The purpose of the document is to provide a means for the field interviewers (samplers) to summarize their activities on each field assignment in terms of sites visited, arrival and departure times, the number of anglers interviewed, etc. For the pilot project, procedural changes have negated the need for several data fields on the ASF and caused the need for others. For example, since assignments on the pilot project are by specific time interval, a field for this information has been added to the ASF (see item **5**).

While the item-by-item instructions for filling out the ASF are contained in the Field Procedures Manual (Appendix XXX), this document will focus only on the changes. Both the ASF being used in the Pilot as well as the ASF being used in the MRFSS are below.

### Interviewer Code **1**

Many field assignments in the pilot project require the presence of two interviewers. All night assignments (time intervals 1 (0200 hrs to 0800 hrs) and 4 (2000 hrs to 0200 hrs)) require two interviewers due to safety concerns. An additional field has been added to the ASF to accommodate the need for two samplers on assignment. In the MRFSS, head boat mode is the only type of assignment that may require two samplers on the same assignment.

### Mode **2**

The mode of the assignment is predetermined by the sample draw. Mode code 1 = Beach/Bank (BB), 3 = Private/Rental boat (PR), 4 = Man-made (MM), and 5 = Charter boat (CH). Head boat mode (HB) was not included as part of the pilot project.

### Survey Method **3**

Samplers may be engaged in interviewing anglers, counting anglers (i.e. those anglers not interviewed), or doing both tasks simultaneously while on assignment. This field is used to document the start and end times, and the survey method, for every time period during the assignment. For example, if one sampler is given an assignment during time interval 2 (0800 hrs to 1400 hrs) and is able to both interview and count anglers during the time period of 0800 hrs to 1000 hrs, the survey method for this time period would be coded as "3". The time period for any survey method is ideally 60 minutes but there may be instances where less time can be spent on the task (for instance, at the end of the time interval or assignment, or when interviewing an angler or group of anglers takes longer than anticipated). Most importantly, this field serves as a means of documenting the time period and method.

## Angler Trips 4

The purpose of this field is to document the number of angler trips during specific time periods, and applies only to *counted* anglers but not *interviewed* anglers. For example, if the sampler is engaged in both interviewing and counting anglers during the time period of 0800 hrs to 1000 hrs, and while actively interviewing anglers saw another seven anglers leave the site, “07” would be entered in the field for “unconfirmed trips”. Unconfirmed trips represent anglers that the sampler was unable to speak with to confirm they actually fished that day. Similarly, “confirmed trips” *require* verbal confirmation by the anglers that a fishing trip took place that day. In the MRFSS, angler trips are summarized at the bottom of the ASF (in the “missed/ineligible” section), pertain to the entire assignment as a whole, and may include both confirmed and unconfirmed trips.

## Assignment Time Interval 5

This field is used to indicate the assigned time interval for the assignment. The four time intervals (1 = 0200 hrs to 0800 hrs; 2 = 0800 hrs to 1400 hrs; 3 = 1400 hrs to 2000 hrs; 4 = 2000 hrs to 0200 hrs) are preselected by the draw program and are not chosen by the samplers. In the MRFSS, sampling times are determined by the individual sampler and may range anywhere from 1 hour to 8 or more hours.

## Status 3 6

This box is for tallying, by site, anglers that refuse to be interviewed. A “status 3” interview is one in which the angler refuses to answer any of the questions; AKA an “initial refusal”. These anglers are NOT included in section 4, Angler Trips. The totals from this area for each site are transferred to the section below titled “Interview Status” under the number “3” at the end of the assignment.

## Status 4 7

This box is for tallying, by site, anglers for which interviews were not conducted due to a language barrier. These anglers are NOT included in section 4, Angler Trips. The totals from this area for each site are transferred to the section below titled “Interview Status” under the number “4” at the end of the assignment.

## Confirmed 8

This box is for tallying, by site, anglers for which the interviewer was able to confirm completed a fishing trip. In order to be considered a “confirmed” trip the interviewer must have spoken

with the angler. The totals from this area are transferred to section 4 at the end of the assignment.

### **Unconfirmed** 9

This box is for tallying, by site, anglers for which the interviewer was unable to confirm completed a fishing trip. For example, while the interviewer is actively interviewing anglers s/he sees another boat pull out of the water, and notices fishing poles on the boat, but is unable to approach the vessel to speak with the anglers to confirm that they actually fished. The totals from this area are transferred to section 4 at the end of the assignment.

### **Cluster ID** 10

Sites are combined, via a clustering program, into clusters of anywhere from one to three sites, based on established criteria. Numbers are assigned to these clusters via the same program, and are unique by county, mode, month, and year. Clusters are selected via the draw program and then issued to samplers.

### **Site Number listing** 11

This section is essentially unchanged with the exception of wording. In the MRFSS, samplers are issued a primary assignment (site) but are allowed to visit up to two alternate sites. The samplers were allowed to select the alternate sites. In the pilot project, the process of clustering the sites removes sampler discretion by predetermining the sites to be visited on each assignment (the site cluster). Each assignment that is issued to the samplers includes the cluster ID, the individual sites, and the order in which each of those sites is to be visited.

### **Weigh Station** 12

The sampling design of the MRFSS prohibited sampling at a tournament weigh station. The pilot project includes these sites. This space is to allow the interviewer to document which, if any, of the sites in the assignment were a tournament weigh station.

### **Ineligible** 13

This section is for tallying, by site, anglers that are ineligible to be interviewed. The categories are “Not Done” which includes anglers that are still fishing when the interviewer leaves the site; “Not Rec” which includes anglers that did not fish recreationally (i.e. commercial anglers); “Not Salt” which includes anglers that did not fish in marine waters; and “Not Fin” which includes anglers that did not fish for finfish (i.e. clammers, crabbers, etc.). This section differs slightly from that of the MRFSS in that the categories of “Missed” and “Not 5 Yrs” were excluded from the pilot project. Since all “missed” anglers are to be included in section 4, Angler Trips, as

either confirmed or unconfirmed trips, another section here would be redundant. “Not 5 Yrs” refers to anglers that were not interviewed because they were under 5 years of age. In the pilot project, anglers are not excluded based on their age, so this category was removed. An additional category in the MRFSS is “Not U.S.” which refers to anglers that were fishing in international waters. These anglers are still excluded from the survey, however it was determined that this is an extremely rare event in North Carolina and the field was removed for the pilot.

**Reason for leaving site codes** 14

This section includes reasons the interviewer left the assigned site. In the MRFSS, there were several reasons, many related to the number of anglers at the site, why the interviewer would have left the site but in the pilot project there are only a few valid reasons for leaving the site. Codes 6 – 9 are identical for the pilot project and the MRFSS. Codes 10 – 13 have been added for the pilot project: 10 = two hour sampling time ended; 11 = 6 hour sampling time ended; 12 = site closed after hours (specify closing time in comments); 13 = site closed due to other reason (specify in comments); 14 = site unsafe during sample period.



# 2010 MRIP ASSIGNMENT SUMMARY FORM

Do not include intercepted anglers in completed trips section!

1<sup>ST</sup> INTERVIEWER 1  
 2<sup>ND</sup> INTERVIEWER

NAME: \_\_\_\_\_  
 SIGNATURE: \_\_\_\_\_

2 0 1 0    YYYYY MM DD

3 SURVEY METHOD: 4 (COMPLETED) ANGLER TRIPS  
 1=INTERVIEW, 2=COUNT, 3=BOTH, (CONFIRMED BY ANGLER)

MODE: 1=BB, 3=PR, 4=MM, 5=CH 2 STATE  
 COUNTY

CONTROL NUMBER

EDITING HOURS (ROUND TO THE NEAREST 0.25 HR)

5 ASSIGNMENT INTERVAL: 1=0200-0800, 2=0800-1400, 3=1400-2000, 4=2000-0200

ENCOUNTERED ANOTHER INTERVIEWER: 1=YES, 2=NO IF YES SITE NO: \_\_\_\_\_

	START TIME				STOP TIME				SITE				CONFIRMED		UNCONFIRMED	
← Totals _____																

COMMENTS:  
 \_\_\_\_\_  
 \_\_\_\_\_  
 \_\_\_\_\_  
 \_\_\_\_\_  
 \_\_\_\_\_  
 \_\_\_\_\_  
 \_\_\_\_\_

SITE	STATUS 3	STATUS 4	CONFIRMED	UNCONFIRMED
1 <sup>ST</sup>				
2 <sup>ND</sup>	<span style="border: 1px solid red; padding: 2px;">6</span>	<span style="border: 1px solid red; padding: 2px;">7</span>	<span style="border: 1px solid red; padding: 2px;">8</span>	<span style="border: 1px solid red; padding: 2px;">9</span>
3 <sup>RD</sup>				

10 CLUSTER ID        

SITE

1 <sup>ST</sup> SITE				
2 <sup>ND</sup> SITE				
3 <sup>RD</sup> SITE				
___ SITE				
TOTALS				

12 WEIGH STATION: 1=YES, 2=NO

INTERVIEW STATUS

1 & 2	3	4	5

INELIGIBLE

NOT DONE	NOT REC	13 NOT SALT	NOT FIN

14 REASON FOR LEAVING SITE

- REASON FOR LEAVING SITE CODES
- 06 COULDN'T FIND SITE
- 07 OTHER INTERVIEWER PRESENT
- 08 ASKED TO LEAVE
- 09 OTHER (SPECIFY IN COMMENTS)
- 10 2HR SAMPLING TIME ENDED
- 11 END OF 6HR SAMPLING TIME
- 12 SITE CLOSED AFTER HOURS (TIME IN COMMENTS)
- 13 SITE CLOSED OTHER (SPECIFY IN COMMENTS)
- 14 SITE UNSAFE DURING SAMPLE PERIOD

3 = Initial Refusal, 4 = Language Barrier, 5 = Refused Key Item

**Standard ASF for comparison**

**2010 ASSIGNMENT SUMMARY FORM**

ASSIGNMENT NUMBER (Indicate if this is your 1<sup>st</sup> or 2<sup>nd</sup> assignment for the day)

Interviewer ID

2 0 1 0 / MM/DD COMPLETED

STATE

MODE (SH=1; PR=3; CH=5, HB=6)

CONTROL NUMBER

NAME: \_\_\_\_\_

SIGNATURE: \_\_\_\_\_

Office Use Only:

SA \_\_\_\_\_

SE \_\_\_\_\_

DE \_\_\_\_\_ DB # \_\_\_\_\_

List sites in order visited. Include all return visits. No more than alternate sites should be visited.

START TIME				STOP TIME				SITE			

COMMENTS:

\_\_\_\_\_

\_\_\_\_\_

\_\_\_\_\_

\_\_\_\_\_

\_\_\_\_\_

**IF MODE = 6 Complete Items in this box:**

Vessel Name: \_\_\_\_\_

IF YOU RODE A HB WITH ANOTHER INTERVIEWER. PLEASE LIST THE INTERVIEWER ID.

\_\_\_\_\_

\_\_\_\_\_ HEADBOAT DOCK TO DOCK HRS (round to nearest .25 hrs)

\_\_\_\_\_ TOTAL ON-SITE HRS (round to nearest .25 hrs)

\_\_\_\_\_ EDITING HOURS (round to nearest .25 hrs)

\_\_\_\_\_ TOTAL MILES (Round to nearest mile)

REASON FOR FIRST ALTERNATE SITE (See codes to the right)

EDITING: START: \_\_\_\_\_ STOP: \_\_\_\_\_ TOTAL ED. HRS: \_\_\_\_\_

TRAVEL: END ODOM: \_\_\_\_\_ BEGIN ODOM: \_\_\_\_\_ TOTAL MILES: \_\_\_\_\_

Reason For First Alternate Site Codes

01 No activity in mode (weather unfavorable)	04 Got quota in mode	07 Another interviewer present
02 No activity in mode (weather favorable)	05 Tournament weigh station	08 Asked to leave site
03 Fewer than 8 in mode	06 Couldn't find assigned site	09 Other (specify in comments)

**SUMMARY**

	County			Site				Status 1&2 Interviews							
	SH	PR	CH	SH	PR	CH	HB	SH	PR	CH	HB				
Asn. site															
1 <sup>st</sup> Alt.															
2 <sup>nd</sup> Alt.															
<b>TOTALS</b>															

**Other Status Interviews**

3	4	5

3 = Initial Refusal, 4 = Language Barrier, 5 = Refused Key Item

**Missed/Ineligible**

Missed	Not Done	Not U.S.	Not Rec	Not Salt	Not Fin	Not 5 Yrs

All sites must be in same county.

Appendix D  
Site Description Forms

## 2010 MRIP Site Description Form

The Site Description Form (SDF) is a standard form that's been in use since the beginning of the Marine Recreational Fisheries Statistics Survey (MRFSS). The purpose of the document is to provide a means for the field interviewers (samplers) to document (e.g. update, correct, elaborate on) information about a particular site. The information is typically used for maintenance of the Site Register though is not maintained in a separate database as are the data from the Assignment Summary Form (ASF). For the pilot project, procedural changes have necessitated changes to the SDF, such as with regards to assigning site pressures by time interval (see item **8**). Perceived shortcomings in the usefulness of the SDF were also addressed in the pilot project, and several fields were enhanced.

While the item-by-item instructions for filling out the SDF are contained in the Field Procedures Manual, this appendix focuses only on the changes. Both the SDF used in the pilot project as well as the SDF being used in the MRFSS are below.

### Interviewer Code **1**

Many field assignments in the pilot project require the presence of two interviewers. All night assignments (time intervals 1 (0200 hrs to 0800 hrs) and 4 (2000 hrs to 0200 hrs)) require two interviewers due to safety concerns. An additional field has been added to the SDF to accommodate the need for two samplers on assignment. In the MRFSS, head boat mode is the only type of assignment that may require two samplers on the same assignment.

### Weather Conditions **2**

The SDF used in the MRFSS contained two checkboxes for weather conditions, "favorable (conducive to fishing)" and "unfavorable (rainy, windy, unseasonably cold)". These fields were modified for the pilot project to establish separate, quantifiable, checkboxes for cloud cover, wind, and precipitation in order to better document field conditions at the time of the assignment.

### Latitude / Longitude **3**

Obtaining coordinates of every site has long been the practice in the MRFSS; however, there has never been a separate field on the SDF for documenting these coordinates. Coordinates are obtained and recorded in degrees, minutes, and decimal seconds. Coordinates are not required every time a site is visited but are periodically verified.

### New Site **4**

Discovering new sites isn't a common occurrence in the MRFSS, and would be rarer in the pilot project because the sites to be visited are specified entirely through the draw program (i.e. the

samplers are not allowed to visit alternate sites of their choosing). Despite this, this checkbox was added to the form for clarity in the event of the discovery of a new site.

### **Night Fishing BB** 5

In the MRFSS, this section only contained a field for documenting night fishing in shore (man-made and beach / bank combined) and private/rental boat modes. This particular field is used to indicate whether or not night fishing in beach / bank mode exists.

### **Night Fishing MM** 6

In the MRFSS, this section only contained a field for documenting night fishing in shore (man-made and beach / bank combined) and private/rental boat modes. This particular field is used to indicate whether or not night fishing in man-made mode exists.

### **Night Fishing CH** 7

In the MRFSS, this section only contained a field for documenting night fishing in shore (man-made and beach / bank combined) and private/rental boat modes. This particular field is used to indicate whether or not night fishing in charter boat mode exists.

### **Pressure Estimates (definition)** 8

In the MRFSS, pressure estimates referred to “the mode and site specific average number of anglers expected to use that mode and site over an 8-hour period of peak activity on an average day, expressed in the Master Site Register as a categorical value. The value must be representative of the average daily activity over the entire month.” Because specific six-hour time intervals are being sampled in the pilot project, the time frame for estimating fishing pressure was changed accordingly.

### **Pressure Estimates** 9

Fields are provided for estimating fishing pressure by mode, day-type, time interval and month. In the MRFSS, samplers were asked to estimate fishing pressure for all modes at the site. In the pilot project, samplers are instructed to estimate fishing pressure for the specific mode of the current assignment, and only for the specific time interval they are currently working.

### **Comments** 10

This area is used to document any information about the site, such as charter boats that use the site, web sites, hours of operation, etc. Comments may be added to the “notes” field in the Master Site Register.

1<sup>ST</sup> INTERVIEWER

## 2010 SITE DESCRIPTION FORM

STATE

1

2<sup>ND</sup> INTERVIEWER

COUNTY

YYYY MM DD

3

SITE

WEATHER  
CONDITIONS  
(ONE PER  
COLUMN) CLEAR NO WIND (0  
KNOTS) NO  
PRECIPITATION PARTLY  
CLOUDY BREEZY (1-  
16 KNOTS) RAIN CLOUDY WINDY (17-33  
KNOTS) SNOW STRONG WIND  
(34+ KNOTS) MIX

LATITUDE N

LONGITUDE W

4

NEW SITE

SITE NAME \_\_\_\_\_

STREET ADDRESS \_\_\_\_\_

CITY \_\_\_\_\_

STATE

ZIP

CONTACT NAME \_\_\_\_\_

PHONE

DIRECTIONS FROM MAJOR HIGHWAY \_\_\_\_\_

## MODES PRESENT/SITE ATTRIBUTES

YES NO CANNOT  
DETERMINE

MAN-MADE

6

NIGHT FISHING MM?

YES NO CANNOT  
DETERMINE

PRIVATE ACCESS?

BEACH/BANK

NIGHT FISHING PR?

CAN WE  
INTERVIEW?

HEAD BOAT

NIGHT FISHING CH?

FISHING PRESSURE  
AFFECTED BY TIDE?CHARTER  
BOATADEQUATE  
LIGHTING?

# HB USING SITE

PRIVATE/RENTAL  
BOAT

SAFE AT NIGHT?

# CH USING SITE

NIGHT FISHING  
BB?

5

COMMERCIAL FEE  
FOR USE OF SITE? (EX:  
ENTRANCE/LAUNCHING/  
PARKING FEE.)



**Standard SDF for comparison**

# 2010 SITE DESCRIPTION FORM

Is there any new information on this form?  
 Yes  No

/
 

 MM/DD

Interviewer ID

STATE 

  
 COUNTY 

  
 SITE

Assigned Site?  Yes  No  
 Head Boat Ride?  Yes  No

Upon Arrival	Upon Departure	Weather
Time <input type="text"/> <input type="text"/> : <input type="text"/> <input type="text"/>	Time <input type="text"/> <input type="text"/> : <input type="text"/> <input type="text"/>	<input type="checkbox"/> Favorable (conducive to fishing)  <input type="checkbox"/> Unfavorable (rainy, windy, unseasonably cold)
# of SH anglers <input type="text"/> <input type="text"/>	# of SH anglers <input type="text"/> <input type="text"/>	
# of boat trailers <input type="text"/> <input type="text"/>	# of boat trailers <input type="text"/> <input type="text"/>	
<b>TOTAL # of charter boats that use this site:</b> <input type="text"/> <input type="text"/>		<b>TOTAL # of head boats that use this site:</b> <input type="text"/> <input type="text"/>

Site Name: \_\_\_\_\_

Site Street Address: \_\_\_\_\_

Site City/Town: \_\_\_\_\_ Site State: 
 ZIP Code:

Directions from recognizable landmark: \_\_\_\_\_

\_\_\_\_\_

Contact Person: \_\_\_\_\_ Phone Number: (     ) \_\_\_\_\_

### Modes Present at Site/ Attributes of Site

	Yes	No	Cannot Determine		Yes	No	Cannot Determine		Yes	No	Cannot Determine
Man-made shore?	<input type="checkbox"/>	<input type="checkbox"/>	<input type="checkbox"/>	Night fishing SH?	<input type="checkbox"/>	<input type="checkbox"/>	<input type="checkbox"/>	Private access?	<input type="checkbox"/>	<input type="checkbox"/>	<input type="checkbox"/>
Beach/Bank shore?	<input type="checkbox"/>	<input type="checkbox"/>	<input type="checkbox"/>	Night fishing PR?	<input type="checkbox"/>	<input type="checkbox"/>	<input type="checkbox"/>	Can we interview?	<input type="checkbox"/>	<input type="checkbox"/>	<input type="checkbox"/>
Party/Head boat?	<input type="checkbox"/>	<input type="checkbox"/>	<input type="checkbox"/>	Adequate lighting?	<input type="checkbox"/>	<input type="checkbox"/>	<input type="checkbox"/>	Fishing pressure affected by tide?	<input type="checkbox"/>	<input type="checkbox"/>	<input type="checkbox"/>
Charter boat?	<input type="checkbox"/>	<input type="checkbox"/>	<input type="checkbox"/>	Safe at night?	<input type="checkbox"/>	<input type="checkbox"/>	<input type="checkbox"/>				
Private/Rental boat?	<input type="checkbox"/>	<input type="checkbox"/>	<input type="checkbox"/>	Fee for use of site? <i>Ex: Entrance/launching fee</i>	<input type="checkbox"/>	<input type="checkbox"/>	<input type="checkbox"/>				



**Standard SDF for comparison**

**CODES FOR SH, PR, AND CH PRESSURE ESTIMATES**

9 = 0 Anglers/Mode not Present At Site	3 = 13-19 Anglers Present	6 = 50-79 Anglers Present
0 = 1-4 Anglers Present	4 = 20-29 Anglers Present	7 = 80 + Anglers Present
1 = 5-8 Anglers Present	5 = 30-49 Anglers Present	8 = Can Not Determine Pressure
2 = 9-12 Anglers Present		

**This Wave:**

What is your estimate of the number of eligible anglers expected during an eight-hour period of weekend/ weekday activity for each month of this wave? **If this is not the same as indicated in the site register, explain in the comments section.**

Month 1: \_\_\_\_\_

	SH	PR	CH
Weekend pressure			
Weekday pressure			

Month 2: \_\_\_\_\_

	SH	PR	CH
Weekend pressure			
Weekday pressure			

**Peak Productivity**

Morning  
6-10am

Mid-day  
10am-2pm

Afternoon  
2-6pm

Evening  
6pm-midnight

**HEAD BOAT ACTIVITY**

*(Complete this section if you are riding a head boat)*

NAME OF HEAD BOAT _____
VESSEL ID NUMBER _____

**This Wave:**

What is your estimate of the number of trips this head boat will take per week on weekdays for each month of this wave? What is the estimate of the number of trips this head boat will take per week on weekend days? (Please keep in mind that pressure codes above should not be used for HB mode. Please fill in actual estimated number of trips in boxes provided. For example: During a typical week the "MACKEREL" takes 3 trips per weekend day, so the total # of weekend trips = 6. During a typical week the "MACKEREL" takes two trips per weekday, so the total # of weekday trips = 10.)

**Month 1:    Month 2:**

	_____	_____
Weekend HB		
Weekday HB		

Comments:

---



---



---



---

## Appendix E

Detailed examination of strata level catch estimates with very large differences between the Pilot and MRFSS

To help identify the causes of observed differences, estimates and data components for both surveys used to compute total catch were examined. The following components were analyzed and compared:

- (i) both Claim and Harvest components for landings estimates and Release for released alive;
- (ii) number of intercepted anglers (sample size);
- (iii) distributions of fish encountered, expressed in raw (unweighted) number of anglers, for a specified species;
- (iv) difference between weighted and unweighted catch rates from pilot APAIS data:
  - a) a large absolute difference implies extreme weights may apply to some extreme value of observations, and then,
  - b) examine both psu and overall weights associated with individual intercepts;
- (v) differences in effort estimates due to the different estimates of proportion in fishing area, coastal resident anglers, and off FHS frame boats.

Table 1 shows the particular estimates compared with more a detailed explanation of what caused the large differences found between pilot and MRFSS for this small subset of cells.

Table ?. Explanation of NC pilot and (weighted) MRFSS catch estimate comparisons with relatively large absolute differences in numbers of fish.

Estimate	NC Pilot	MRFSS	Explanation
Bluefish, CH, wave 4, area_x=1, Claim	933	61,407	MRFSS catch rate much higher due to 14 trips with 20+ fish (n=176) including one trip with 120 fish. Pilot had only 2 positive trips (1 and 4 fish, n=17).
Kingfish, BB, wave 3, area_x=1, Claim	1,040	93,688	MRFSS catch rate much higher due to 34 positive trips (n=910) including one with 38 fish and one with 58 fish. Pilot had only 1 positive trip, 2 fish (n=97)).
Pinfish, PR, wave 3, area_x=5, Released	3,058,454	170,413	Extremely large weight applied to 1 large catch (20 fish) in pilot
Red drum, PR, wave 6, area_x=1, Released	424,047	5,218	Extremely small sample size for pilot (n=4) combined with large catches
Southern Flounder, BB, wave 5, area_x=1, Claim	57,350	4,288	Rare event catch. One positive catch trip (3 fish) out of 83 intercepts in pilot. One fish for 6 trips and 2 fish for 1 trip out of 1190 trips for MRFSS.
Spot, BB, wave 3, area_x=1, Released	1,021	122,397	MRFSS catch rate much higher due to 33 positive trips (n=910) including 11 with five or more fish. Pilot had only 1 positive trip, 1 fish (n=97)).
Spot, MM, wave 3,	313,665	5,473	Distribution of pilot catch is wider than MRFSS.

area_x=1, Harvest			Large weights are applied to large catches (>10 fish) in pilot
Spot, MM, wave 5, area_x=1, Harvest	1,644,274	53,869	Distribution of pilot catch is wider than MRFSS. Large weights applied to a few very large catches (80+ fish) in pilot.
Spot, MM, wave 6, area_x=1, Claim	5,132	67,278	Pilot catch rate much lower due to only 3 positive trips (n=118). MRFSS had 29 positive trips (n=274) including some very large catches.
Spotted seatrout, PR, wave 5, area_x=5, Released	17,546	422,051	Distribution of MRFSS catch is wider than pilot. Pilot had no trips with more than 5 fish (n=146), MRFSS had 70 trips (n=1615).
Spotted seatrout, BB, wave 6, area_x=5, Released	432,398	122,345	Effort estimate applied to catch rate much higher for pilot (48,300) than MRFSS (14,244) with larger estimated proportion in area_x=5



## APPENDIX F

### Controlled Selection Program for the Access Point Angler Intercept Survey

A controlled selection program was developed and tested for possible use with future applications of the new sampling design for the Access Point Angler Intercept Survey (APAIS). The program is written in SAS to generate a number of alternative sets of interviewing assignments that could be covered by existing staff. The program then randomly selects one set of assignments to be completed by the APAIS interviewers. The objective is to avoid selecting more assignments for any given day than the team of interviewers can complete. The nature of the constraints and the order in which they are applied in the program are described below. In the example described, a set of October assignments is drawn for one North Carolina subregion in which only 3 full-time samplers are available to complete assignments. As shown in the “Background Data” section below, the program considers all available days in the month for each day type (weekend/holiday and weekday). It also requires an input allocation of sampling among fishing mode and time-block strata for each day type, as well as an input number of available samplers. A number of constraints are listed below that are applied sequentially to place restrictions on the possible sets of assignments that can be generated for selection. Different constraints are set for nighttime assignments (always two samplers per assignment) and daytime assignments (always one per assignment).

#### Background Data

Available days in October 2010

KOD	Days in October 2010
11 days in WE	2, 3, 9, 10, 11, 16, 17, 23, 24, 30, 31
20 days in WD	1, 4, 5, 6, 7, 8, 12, 13, 14, 15, 18, 19, 20, 21, 22, 25, 26, 27, 28, 29

Number of Assignments allocated to NC Northern Region by Mode, Time Interval and Kind of Days

Mode	D:8PM-8AM		B:8AM-2PM		C:2PM-8PM	
	WE	WD	WE	WD	WE	WD
BB	1	1	2	1	2	1
MM	2	1	2	1	2	1
PR	1	1	2	2	2	2
CH	0	0	2	1	3	3

Number of samplers

	Northern	Central	Southern
# samplers	3	4	3

Constraints:

- One assignment per sampler per day  $\equiv$  Maximum 3 assignments (D:8PM-8AM, B:8AM-2PM or C:2PM-8PM) per day
- Night-time assignments require 2 samplers, which is a determined factor in sampling design
- Since night-time assignment require most of sampling effort under limited number of samplers, Do night-time (D:8PM-8AM) Selections in WE and WE first.
- The remaining possible assignments per day are available for B:8AM-2PM and C:2PM-8PM.

### **Night-time (D:8PM-8AM) Selections**

#### **Constraints:**

- 2 samplers per night-time assignment
- One night-time assignment per day because only 3 samplers are available
- WE and WD night-time assignment selections are independent

#### ***N Region; WE; D:8PM-8AM***

Set of allocation by mode(N; WE; D:8PM-8AM) = {BB, MM1, MM2, PR} is given

Select a set of 4 distinct, unordered WE days, days(N; WE; D:8PM-8AM), from total of 11 WE days in October 2011

- Approximated by simple random sampling without replacement
- Number of possible sets =  $C(11, 4) = \frac{11!}{4!(11-4)!} = 330$

Arrange of the 4 allocated modes to the selected days(N; WE; D:8PM-8AM)

- Permutations of 4 allocated modes =  $4! = 24$
- Total possible arrangements of mode(N; WE; D:8PM-8AM) and days(N; WE; D:8PM-8AM) =  $330 \times 24 = 7,920$
- Generate a random variable from Uni(0,1) for each of modes, {BB, MM1, MM2, PR}
- Rearrange {BB, MM1, MM2, PR} by the order of random variables
- Probability of a mode-day =  $1/7,920$

#### ***N Region; WD; D:8PM-8AM***

Set of allocation by mode(N; WE; D:8PM-8AM) = {BB, MM, PR} is given

Select a set of 3 distinct, unordered WE days, days(N; WE; D:8PM-8AM), from total of 20 WE days in October 2011

- Approximated by simple random sampling without replacement
- Number of possible sets =  $C(20, 3) = \frac{20!}{3!(20-3)!} = 1,140$

Arrange of the 3 allocated modes to the selected days(N; WE; D:8PM-8AM)

- Permutations of 4 allocated modes = \_\_\_\_\_
- Total possible arrangements of mode(N; WE; D:8PM-8AM) and days(N; WE; D:8PM-8AM) = 1,040 x 6 = 6,240
- Generate a random variable from Uni(0,1) for each of modes, {BB, MM, PR}
- Rearrange {BB, MM, PR} by the order of random variables
- Probability of a mode-day = 1/6240

**Day-time (B:8AM-2PM) Selections**

*Constraints*

- 1 sampler per day-time assignment
- The days on and after a night-time assignment may only have (number of samplers – 2) day-time assignments available
- Intuitively, multiple assignments in a day imply days are sampled with replacement
- After Night-time selection, number of possible day-time assignments is summarized (\*: as an example)

WE	<i>D:8PM-8AM</i> *	Remaining assignments	WD	<i>D:8PM-8AM</i> *	Remaining assignments
2 (SAT.)		3	1 (FRI.)		3
3 (SUN.)	MM2	1	4 (MON.)		1
9 (SAT.)		3	5 (TUE.)		3
10 (SUN.)	PR	1	6 (WED.)	BB	1
11 (MON.)		1	7 (THU.)		1
16 (SAT.)		3	8 (FRI.)		3
17 (SUN.)		1	12 (TUE.)		3
23 (SAT.)	BB	0	13 (WED.)		3
24 (SUN.)	MM1	0	14 (THU.)		3
30 (SAT.)		3	15 (FRI.)		3
31 (SUN.)		3	18 (MON.)	PR	1
			19 (TUE.)		3
			20 (WED.)		3
			21 (THU.)		3
			22 (FRI.)		3
			25 (MON.)	MM	1
			26 (TUE.)		1
			27 (WED.)		3
			28 (THU.)		3
			29 (FRI.)		3
sum		19	sum		48

***N Region; WE; B:8AM-2PM***



Set of allocation by mode(N; WE; B:8AM-2PM) = {BB1, BB2, MM1, MM2, PR1, PR2, CH1, CH2} is given

- Permutations of 8 allocated mode assignments =  $\frac{8!}{1!1!1!1!1!1!1!1!} = 40,320$

Select a set of 8 WE assignments from the remaining 19 WE assignments

- Number of possible selections =  $C(19, 8) = \frac{19!}{8!11!} = 75,582$

Permuting {BB1, BB2, MM1, MM2, PR1, PR2, CH1, CH2} by random variables from UNI(0,1) and fit to the selected days(N; WE; B:8AM-2PM)

- Total possible arrangements of mode(N; WE; B:8AM-2PM) and days(N; WE; B:8AM-2PM) =  $75,582 \times 40,320 = 3,047,466,240$

**N Region; WD; B:8AM-2PM**

Set of allocation by mode(N; WD; B:8AM-2PM) = {BB, MM, PR1, PR2, CH} is given

- Permutations of 5 allocated mode assignments =  $\frac{5!}{1!1!1!1!1!} = 120$

Select a set of 5 WE assignments from the remaining 48 WE assignments

- Number of possible selections =  $C(48, 5) = \frac{48!}{5!43!} = 1,712,304$

Permuting { BB, MM, PR1, PR2, CH} by random variables from UNI(0,1) and fit to the selected days(N; WE; B:8AM-2PM)

- Total possible arrangements of mode(N; WE; B:8AM-2PM) and days(N; WE; B:8AM-2PM) =  $120 \times 1,712,304 = 205,476,480$

**Day-time (C:2PM-8PM) Selections**

\*: for illustration only

WE	D:8PM-8AM selection*	B:8AM-2PM selection*	Remaining assignments	WD	D:8PM-8AM Selection*	B:8AM-2PM selection*	Remaining assignments
2 (SAT.)		BB2	2	1 (FRI.)			3
3 (SUN.)	MM2		1	4 (MON.)			1
9 (SAT.)		MM2	2	5 (TUE.)		BB	2
10 (SUN.)	PR	PR1	0	6 (WED.)	BB		1
11 (MON.)			1	7 (THU.)			1
16 (SAT.)		MM1, BB1	1	8 (FRI.)			3
17 (SUN.)		CH1	0	12 (TUE.)		MM	2
23 (SAT.)	BB		0	13 (WED.)			3
24 (SUN.)	MM1		0	14 (THU.)			3
30 (SAT.)		CH2	2	15 (FRI.)			3

31 (SUN.)		PR2	2	18 (MON.)	PR		1
				19 (TUE.)			3
				20 (WED.)		PR1, PR2	1
				21 (THU.)			3
				22 (FRI.)			3
				25 (MON.)	MM		1
				26 (TUE.)		CH	0
				27 (WED.)			3
				28 (THU.)			3
				29 (FRI.)			3
sum			11	sum			43

***N Region; WE; C:2PM-8PM***

Set of allocation by mode(N; WE; C:2PM-8PM) = {BB1, BB2, MM1, MM2, PR1, PR2, CH1, CH2, CH3} is given

- Permutations of 8 allocated mode assignments =  $8! = 40,320$

Select a set of 8 WE assignments from the remaining 19 WE assignments

- Number of possible selections =  $C(19, 8) = 75,581$

Permuting {BB1, BB2, MM1, MM2, PR1, PR2, CH1, CH2} by random variables generated from UNI(0,1) and put to the selected days(N; WE; C:2PM-8PM)

- Total possible arrangements of mode(N; WE; C:2PM-8PM) and days(N; WE; C:2PM-8PM) =  $40,320 \times 75,581 = 3,046,800,320$

***N Region; WD; C:2PM-8PM***

Set of allocation by mode(N; WD; C:2PM-8PM) = {BB, MM, PR1, PR2, CH1, CH2, CH3} is given

- Permutations of 8 allocated mode assignments =  $8! = 40,320$

Select a set of 8 WE assignments from the remaining 19 WE assignments

- Number of possible selections =  $C(19, 8) = 75,581$

Permuting {BB, MM, PR1, PR2, CH1, CH2, CH3} by random variables generated from UNI(0,1) and put to the selected days(N; WE; C:2PM-8PM)

- Total possible arrangements of mode(N; WD; C:2PM-8PM) and days(N; WD; C:2PM-8PM) =  $40,320 \times 75,581 = 3,046,800,320$



Appendix G  
Proposed Fish Sampling Procedures

Under the MRFSS approach samplers were instructed to measure no more than 15 fish of one species per angler. If they encountered an angler with more than 15 fish for a given species instructions for sub-sampling were as follows:

*Line up the fish from largest to smallest, divide the total number by fifteen, and select every nth fish for length and weight measurement. For example, if there are 30 fish of one species, the sampler should line them up by size and select every 2nd fish. This method of sampling would be “systematic random” rather than “simple random.”*

While this approach would, in theory, result in an unbiased systematic random sample, in practice it was very difficult to adhere to in the field and may only be possible under ideal sampling conditions. At many sites there isn't enough room to lay out the fish. In addition, anglers often don't want to spend time waiting for the sampler to line fish up from smallest to largest and on warm days they may object to having their fish outside of the cooler for any length of time. As a result, in the past samplers likely deviated from systematic random sampling and instead used a variety of approaches for sub-sampling fish that involved varying levels of sampler discretion. Such departures from a true probability sample add to the potential for bias associated with mean fish lengths, weights, and expanded weight estimates. One of the objectives of the pilot was to minimize departures from a true probability sample, and reduce the potential for bias, by giving samplers as little discretion as possible in the selection of which fish to measure. However, the objective of selecting an unbiased probability sample of fish had to be balanced with the need for field procedures that are both feasible to implement under a variety of real field conditions and easy to understand by the average sampler.

The sub-sampling procedures implemented for the pilot were as follows:

1. Sampler will count the number of fish per species per angler to determine if sub-sampling is necessary.
2. No more than 10 fish of one species are measured per angler (MRFSS maximum was 15). This maximum was based on an analysis of bag frequency distribution (by species) indicating that only a very small fraction of fish would not be sampled due to this limit.
  - Note: The exception to this rule is in situations where activity at the site is so slow that measuring more than 10 fish per species per angler does not result in missed samplers or missed angler counts.
3. Each sampler will be issued a random numbers table every month, which will be used to sub-sample fish. The table will only include numbers from 1 through 20.
4. When the total number of available fish is **20 or fewer** per species per angler, the random numbers table will be used to **exclude** fish (i.e., to identify the fish that will **not** be measured). The sampler will remove all fish of a given species from the cooler and place them vertically on the measuring board with all heads facing up. Using the random numbers table the sampler will exclude individual fish (by changing the

direction the fish is facing) until only 10 fish remain facing up which are the ones to measure.

5. When the total number of available fish is **greater than 20**, the same table will be used to **include** fish to sample. To include fish the sampler will first need to determine the interval which is simply the number of fish divided by 10 rounded to the nearest whole number (e.g., 38 fish the interval is 4 or every 4th fish). The random number table is then used to determine the starting point. The starting fish must be between 1 and 10 so numbers greater than 10 in the table will be ignored. The sampler will count the fish by transferring them from the angler's cooler to their own bucket. The randomly selected starting fish and every  $n^{\text{th}}$  fish after is placed on the measuring board and measured when done counting.

While laying out the fish and then excluding some with a random numbers table could be time consuming and burdensome to anglers, since the overwhelmingly large majority of anglers keep 10 or fewer fish per species the proposed sub-sampling procedures should only have minimal impact in this regard. However, in some PR mode interviewing situations there often will not be a suitable location, fish will be too large, or there will not be enough time to lay fish out on a measuring board for sampling. Therefore, to accommodate these situations the project team came up with an alternative sub-sampling procedure that samplers could follow under these circumstances. This alternative was viewed as a good compromise that, to the extent possible, minimizes sampler discretion in the selection of fish while still allowing for samples to be taken in situations that otherwise would not be feasible with the protocol described above (#4 & 5).

Alternative Sub-sampling Procedure: Fish are counted as they are removed from the ice chest and placed in a bucket. As the sampler is returning fish to the angler's ice chest, he/she will select the 10 fish for sampling and place them in another bucket. If the number of fish (per species per angler) is 20 or fewer the sampler will select the first (or last) ten counted. To determine which fish are selected for measurement when there are more than 20 fish the same procedure as described in #5 above for excluding fish will be used, except that selected fish will be placed in another bucket instead of lined up on a measuring board.